

Array IR Variable Speed Dome

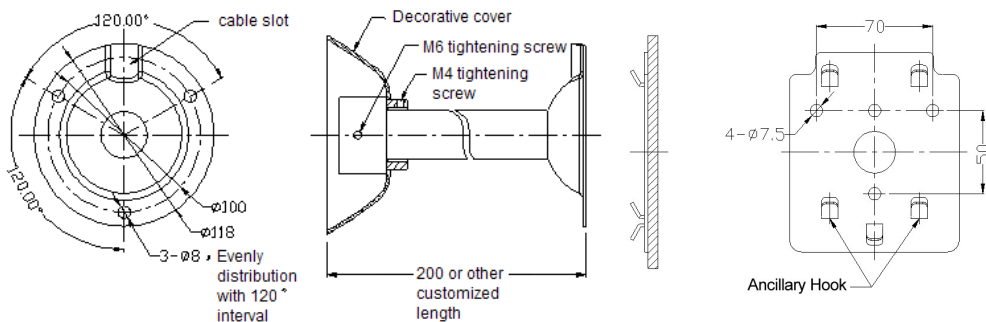

Dimension:

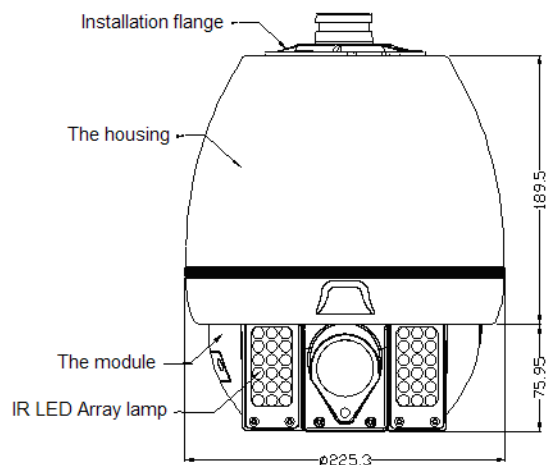

Technical Specifications:

Power Supply	DC15V(4A) (The adaptor should be connected within 2 meters from the IR High-speed Dome)
Working temperature	-30°C~+60°C
Relative Humidity	10-90%
Power Consumption	35W
Communication Protocol	PELCO_D / PELCO_P / PELCO_D1
Communication Method	RS485 bus cable
Communication Baudrate	1200/2400/4800/9600bps
Address range of Speed Domes	1~255
Manually controlling Panning Speed	0.5°~120°/S
Range of Pan/tilt	Pan 360° endless, tilt 0°~+90°
Auto flip function	Auto-flip when vertical 90°
Speed Auto-control as per the changing of zoom ratio	The pan/tilt can automatically adjust the running speed following the change of the zoom ratio
OSD Menu	4 input modes, all the functions of the pan/tilt and the camera module can be operated through the OSD menu
Preset Position number	128
Left & Right scan	The beginning and the end point free to be set, 3 grades of speed (low, medium and high) optional
360° Scan	Vertical angle free to be set, 3 grades of speed (low, medium and high) optional
Tour Group	4 groups, 16 preset positions for 1 tour group, dwelling time at each preset position can be set
Pattern Scan number	4
Privacy Mask Zone number	8
Idle Time functions	The function to be carried out in idle time can be configured, including invoking preset position, Left & Right scan, running tour etc
Alarm Functions	4 channels in, 1 channel out
IR Lamp	2 groups, made up of LED Array, 120m visible distance
Brightness control for IR lamps	Support brightness-control for IR lamps, including auto-control and manual-control 2 modes. The brightness is controlled by controlling the number of the groups of the IR lamps to be turned on.
IR light triggering control	Triggered by photosensitive resistor / triggered by camera module (IR Lamp turned on when camera module turns to Black & White mode), altogether 2 methods
Protection Grade	IP66
Lightening-proof	2 grades anti-lightening design, 3 groups protecting point (video, communication and power)
Weight	5.6Kg