

3" Mini Speed Dome Camera

Technical Specifications:



Dimension:

■ Ceiling type installation dimensions

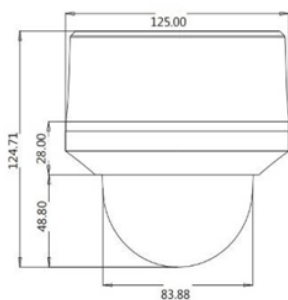

■ Flush type installation dimensions

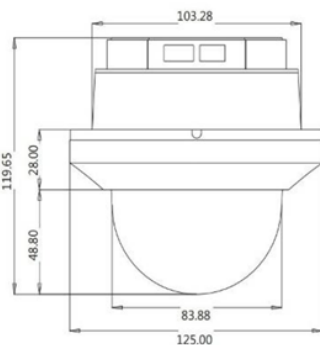

■ Hoisting installation dimensions

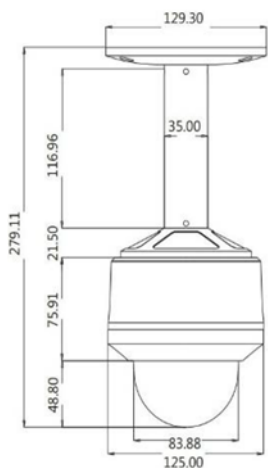

■ Wall installation dimensions

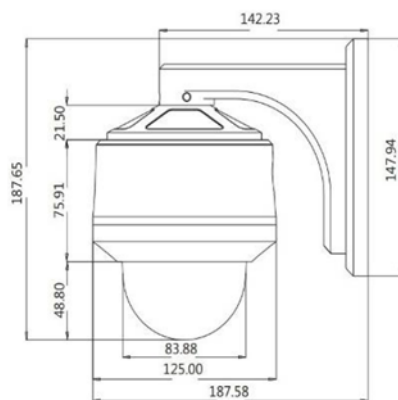

Item	3" Mini Hi-Speed Dome
Image Device	1/3" Sony Ex-View 960H CCD
Video System	PAL/NTSC System
Effective Pixels	976*582 (PAL); 976*494 (NTSC)
Scanning System	2:1 interlace
Resolution	Color: 650TVL; B/W: 700TVL
Day & Night	Auto/Color/B&W (No filter switch)
Min. Illumination	0.01 Lux (Color) / 0.001 Lux (B/W), IRE No
S/N Ratio	≥52dB (AGC Off, Weight ON)
Video Output	CVBS: 1.0Vp-p/75Ω composite
Focal Length	10x Optical Zoom, F=4.9~49mm
Pan/Tilt	
Pan	Pan : 360° (Endless)
Tilt	Tilt: 180° (Auto-Flip)
Pan/Tilt Speed	0.05°~360°/sec
Preset	127 Preset (Label, Camera Image Setting)
Pattern	4 Pattern
Swing	8 Swing
Group	8 Group (20 action entities per Group)
Other Functions	Auto Flip, Auto Parking, Power Up Action etc.
General	
Communication	RS-485
Alarm Input	4 Input (Optional)
OSD Menu	English
Operating Temperature	-20℃~+50℃
Degree of protection	IP66
Input Voltage	DC12V
Power	Max. 0.8A
Color / Material	White (Black bar decoration), Aluminum
Dimension	Dome: Ø83.88mm
	Housing: Ø125 (L) X124.71 (H) mm
Net Weight	980g