



MULTI-DISCIPLINE READERS

ImproX Multi-discipline Readers INSTALLATION MANUAL

SPECIFICATIONS

Read Capability	Slim Tags, Omega Tags, Impro Trinary Tags, FeliCa Tags, MIFARE® Tags, HID 125 kHz Tags and HID iCLASS.	
	<i>NOTE: HID is a registered trademark of HID Global Corporation (an ASSA ABLOY Group Brand).</i>	
Working Environment	Designed to work in an indoor or outdoor environment similar to IP54. The Multi-discipline Readers are therefore sealed (potted) against water.	
Input Voltage Rating	8 V DC to 14 V DC, polarity sensitive.	
Power Requirements	Current (mA)	Power (W)
Supply Voltage 12 V DC all Indicators on.....	130	1.56
Wiegand Bus		
Electrical Interface.....	'0' and '1' Data streams.	
Data Format	Tag information: 44-bit or 26-bit Wiegand. Key information: 26-bit Wiegand only.	
Inputs		
Quantity	4.	
Type	Dry Contact.	
Function	Operation of the Buzzer, LED and Scanner Inhibit.	
Buzzer	4 kHz piezo-electric single volume, single tone.	
Status Indicators		
Status LED	Tri-coloured Red, Green or Amber (Default) (externally visible).	

Optical Anti-tamper Open Collector Output on Purple Line.
GND reference on Grey Line.

NOTE: In OEM applications, connect the Purple and Grey wires to a Dry Contact Input. On ImproX Systems, it is unnecessary to connect these lines as the Software handles the Anti-tamper.

MDK900 model only

Keypad..... 12 Alphanumeric keys.
Keypad Durability Maximum 200 000 key presses.
PIN-codes 5 Digit codes in the range 00000 to 65535.
4 Digit codes in the range 0000# to 9999#.

Blank Space

INSTALLATION INFORMATION

Accessories

Find the following when unpacking the Multi-discipline Reader:

- Either an ImproX (MDR) Multi-discipline Reader (MDR900-5-0-GB-XX) housed in a Polycarbonate and 304 Stainless Steel housing. The Multi-discipline Reader consists of a Front Cover and a Backing Plate. The Backing Plate is attached with 4 clips.
- Or an ImproX (MDK) Multi-discipline Keypad Reader (MDK900-5-0-GB-XX) housed in a Polycarbonate and 304 Stainless Steel housing. The Multi-discipline Reader consists of a Front Cover and a Backing Plate. The Backing Plate is attached with 4 clips.
- One 2-Way Programming Pin.
- A Front Cover Removal Tool.
- An extra Serial Number Label.

General

Remember the following when installing the Multi-discipline Readers:

Maximum Data Communications Distance

Install the Multi-discipline Readers no further than 150 m (164 yd) from the Host unit. The cable individual conductor cross-sectional area should not be less than 0.2 mm^2 (0.0003 in^2).

Distance between Multi-discipline Readers

To avoid mutual interference, install the Multi-discipline Readers no closer than 500 mm (20 in) apart.

Mounting the Multi-discipline Readers

CAUTION: Do NOT attach the Front Cover to the Backing Plate prior to mounting.

CAUTION: Make certain that you mount the Readers on a vibration-free surface.

Select the mounting position of the Multi-discipline Readers, considering accessibility, routing of wires and visibility of the externally visible LED.

Secure the Multi-discipline Readers to the mounting surface, using four suitable screws and wall plugs, nuts and bolts or rivets.

Blank Space

ELECTRICAL CONNECTIONS

Connecting the Multi-discipline Reader

Figure 1 to Figure 5 show typical connections for the Multi-discipline Reader.

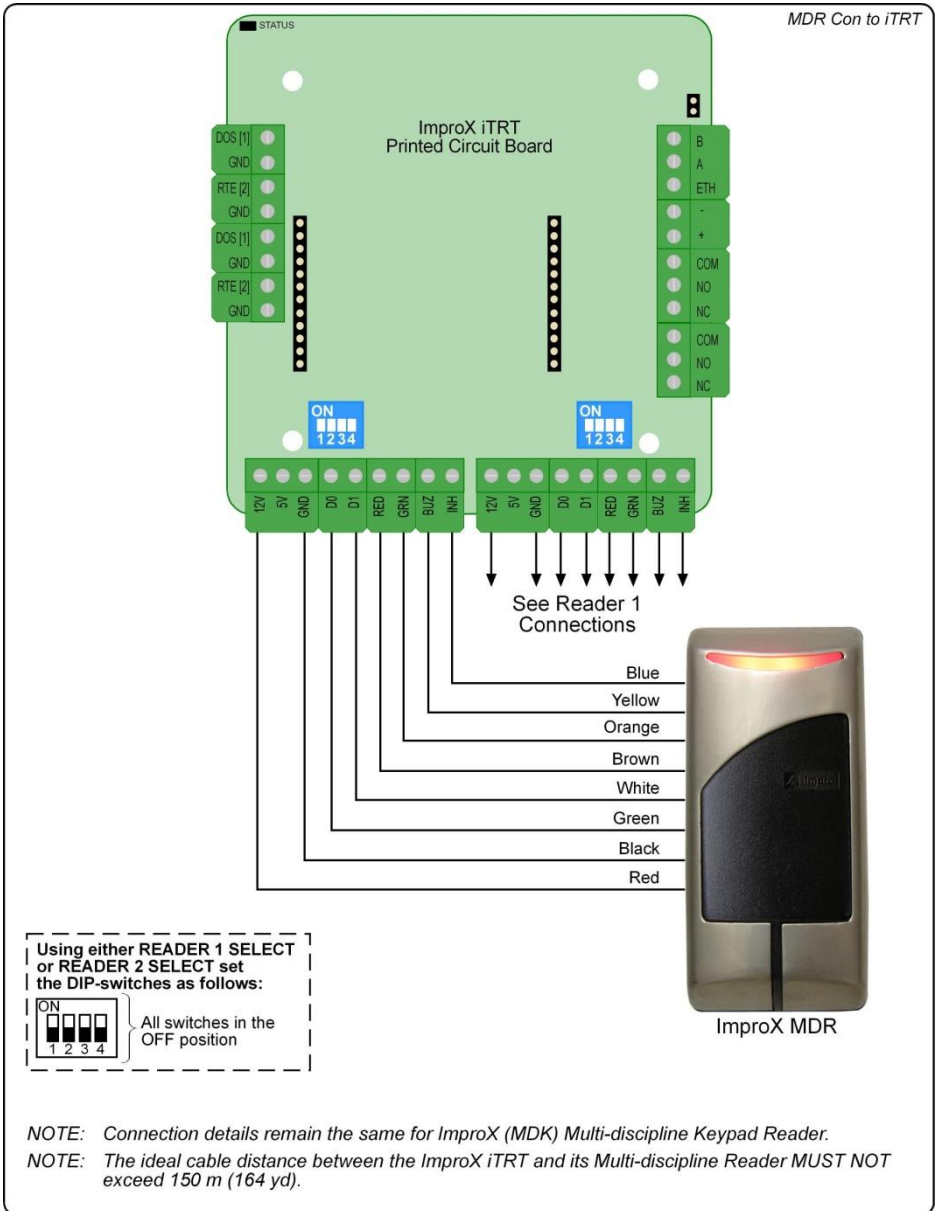

Figure 1: Multi-discipline Reader Connected to the ImproX iTRT

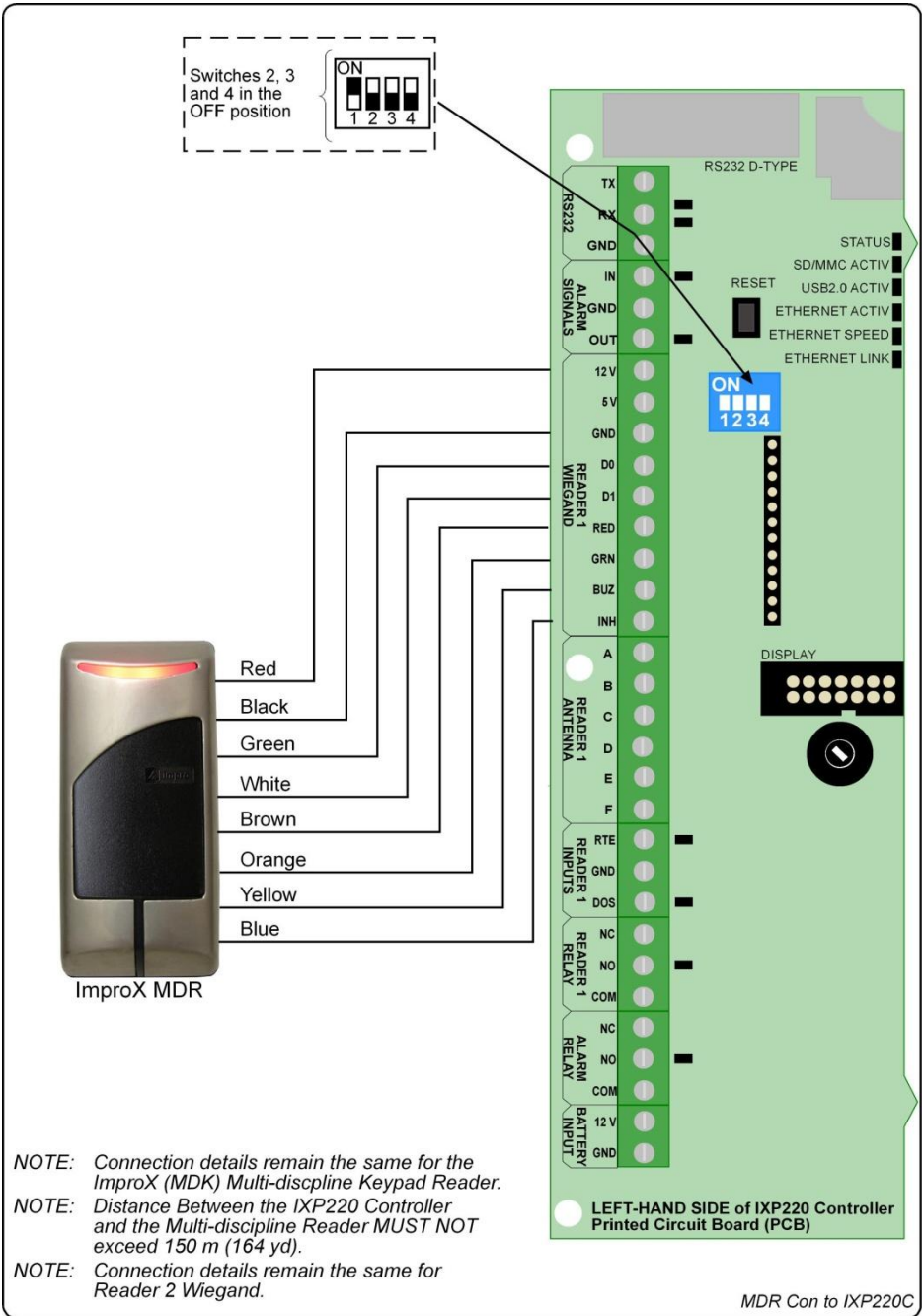

Figure 2: Multi-discipline Reader Connected to the IXP220 Controller

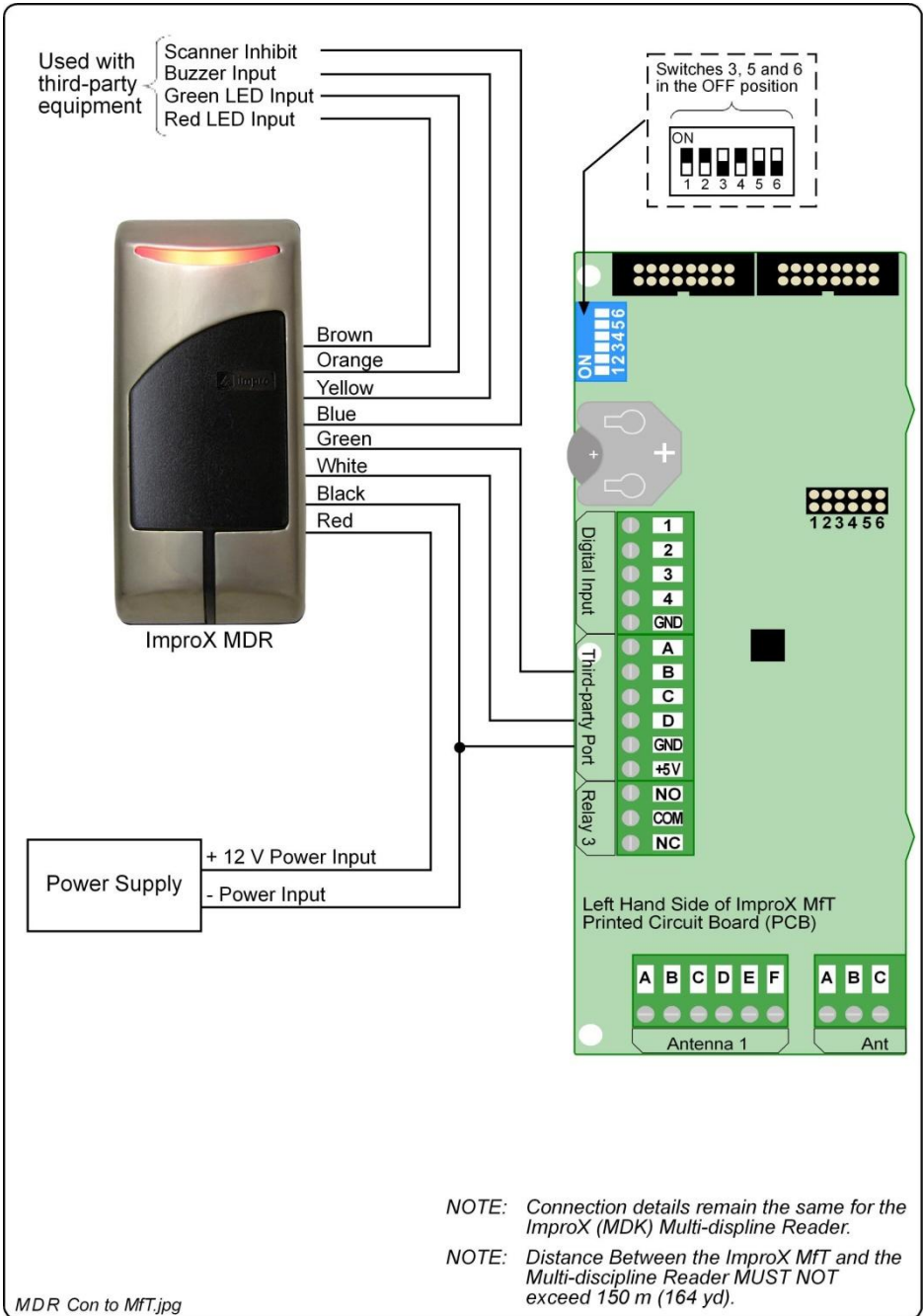

Figure 3: Multi-discipline Reader Connected to the ImproX Mft

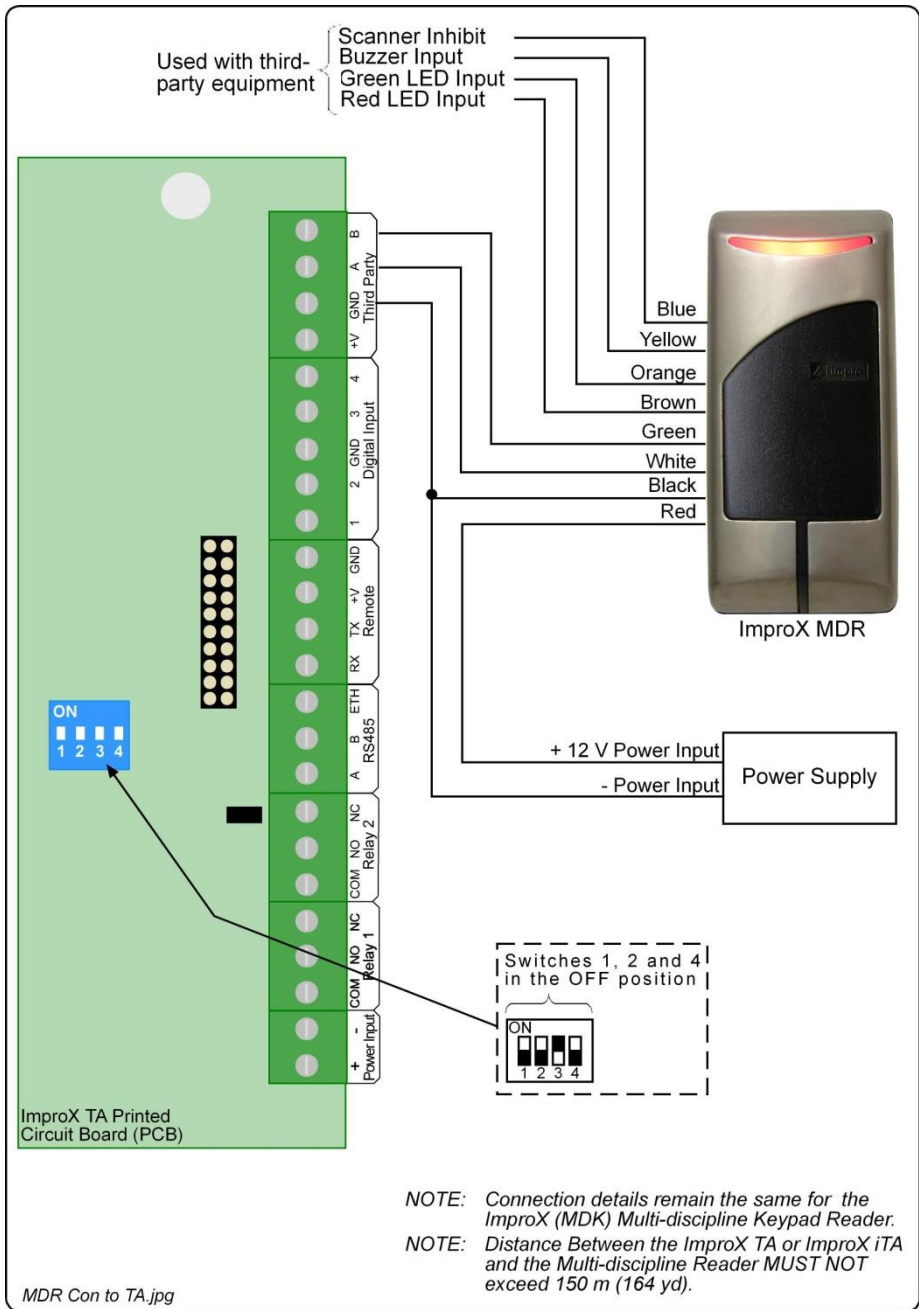

Figure 4: Multi-discipline Reader Connected to the ImproX TA or ImproX iTA

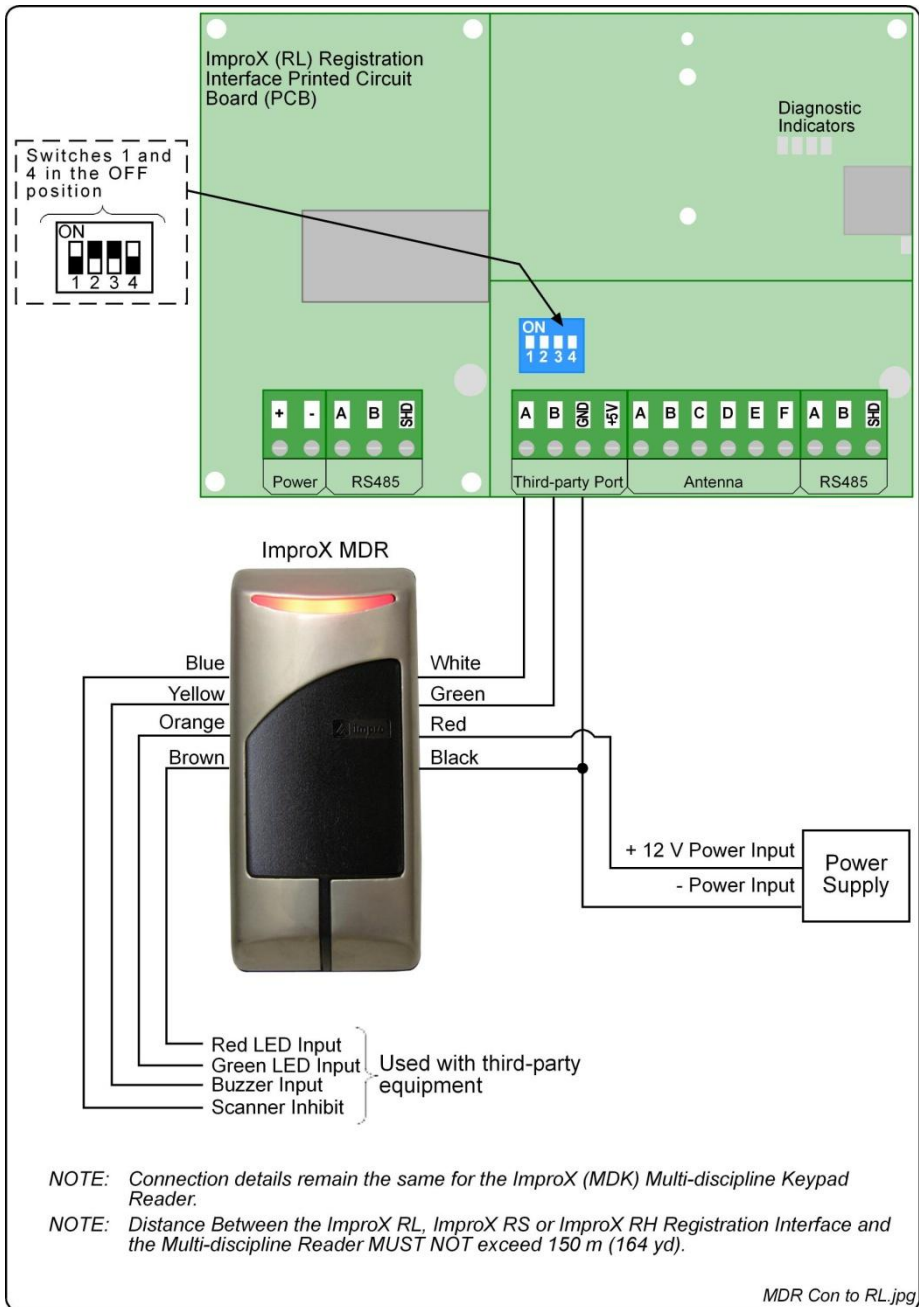

Figure 5: Multi-discipline Reader Connected to the ImproX RL (ImproX RS and ImproX RH)

Configuring the Tag Frequency Mode

The Multi-discipline Readers offer three different Tag Frequency Modes. To select the Tag Frequency Mode, do the following:

1. Power up the Reader. On power up, you have 5 seconds in which to set the Tag Frequency Mode.
2. Present a Tag that matches your chosen Tag Frequency Mode:
 - Mode 1 (125 kHz): If you present a 125 kHz Tag for the full 5-second period, the Reader will only read 125 kHz Tags.
 - Mode 2 (13.56 MHz): If you present a 13.56 MHz Tag for the full 5-second period, the Reader will only read 13.56 MHz Tags.
 - Mode 3 (125 kHz and 13.56 MHz): If you present a 125 kHz Tag for 2 seconds followed by a 13.56 MHz Tag for 2 seconds, the Reader will read both 125 kHz and 13.56 MHz Tags. This is the default mode.

NOTE: If you do not present a Tag within the 5-second period, the Reader uses the last known Tag Frequency Mode.

Setting the Output Mode (OEM Use Only)

CAUTION: Mount the Multi-discipline Reader BEFORE attempting to set the Mode.

The Multi-discipline Readers offer four different Output Mode Combinations. Select the Output Mode by doing the following:

1. Insert the prongs of the Front Cover Removal tool into the recesses provided on the side of the Reader.
2. Apply downward pressure to the Front Cover Removal Tool until the Front Cover unclips.
3. Locate and bridge the two stand-alone Pins using the 2-Way Programming Pin supplied.
4. Power up the unit, the number of beeps indicates the selected Output Mode:
 - Mode 1 (1 Beep): 26-bit, HID Normal.
 - Mode 2 (2 Beeps): 44-bit, HID Normal (Default).
 - Mode 3 (3 Beeps): 26-bit, HID Raw.
 - Mode 4 (4 Beeps): 44-bit, HID Raw.

NOTE: The 26-bit and the 44-bit refer to the output format of EMM and Impro Trinary Tags. HID Tags output in either normal or 45-bit raw mode.

5. Remove the 2-Way Programming Pins once the mode is selected.
6. Clip the Front Cover onto the Backing Plate.

Wiegand 44-bit Protocol

Tags are reported using Wiegand 44-bit Protocol. An “EMM” Tag has an 8-bit User Code and a 32-bit Serial Number.

These are reported as follows:

- The 8-bit User Code is reported in bits 1 to 8 of the Protocol.

- The 32-bit Serial Number is reported in bits 9 to 40 of the Protocol.
- Bits 41 to 44 of the Protocol are the exclusive OR of the preceding 40 bits taken 4 at a time.

Wiegand 26-bit Protocol

Key Codes are reported as a 24-bit code consisting of an 8-bit Facility (or Site) Code, and a 16-bit binary representation of the Key Code.

The following format is used:

- Bit 1 is the even parity over the first 13 bits.
- Bits 2 to 9 are the 8-bit Facility Code for Key Codes.
- Bits 10 to 25 are the 16-bit Key Code.
- Bit 26 is the odd parity over the last 13 bits.

HID Normal

The number of bits to output is determined from the information in the tag and will vary between tags. The 26-bit or 44-bit selection does not impact on HID Tags.

HID Raw

In this Mode, the entire raw 45-bit HID Tag is output.

Keypad Model Settings (MDK900 only)

The 12-button Keypad is used to enter 5-digit PIN-codes in the range 00000 to 65535. Wiegand protocol constraints disallow PIN-codes from 65536 to 99999. In this case the Status LED turns Red and the Buzzer activates for 2 seconds.

The Reader can accept 1 to 4-digit PIN-codes by pressing the Hash Key (#) after you have entered the PIN-code.

Errors made while entering the PIN-code can be corrected by pressing the Star Key (*) followed by the correct PIN-code.

- PIN code up to 5 digits with programmable facility code, output in 26-bit format.
- Fixed length buffered keys from 1 – 11 output in hexadecimal format with optional parity.

NOTE: The output of the PIN-code keypad information is in 26-bit Wiegand format.

Fixed Length Key Output Mode

Once the specified number of keys are pressed, all the buffered keys are output in hexadecimal format:

Key	Output
0	0000
1	0001
2	0010
3	0011
4	0100
5	0101

6	0110
7	0111
8	1000
9	1001
*	1010
#	1011

Table 1: Fixed Length Key Output Mode

Setting the Fixed Length Mode

The number of keys to be buffered and the parity option in the Fixed Length Mode is set as follows:

1. Press and hold down key '2' for 3 seconds. The Status LED enters a fast flash Mode and emits a long beep.
2. Enter a 3 digit number followed by the Hash Key (#). The first 2 digits specify the key buffer length and must be in the range 00 to 11 (eleven). The third digit must be a '0' where there is no parity and '1' where parity is added.

NOTE: If '00' is entered for the key buffer length then the Key Mode reverts to PIN Mode.

3. On acceptance of the setting the Status LED changes to Green.
4. If the settings are rejected the Status LED changes to Red.

Single Key 8-bit Burst Mode

To select this mode, specify the Fixed Length Buffered Mode to be "018". This mode reports each single key press as 8-bit code. Use Single Key 8-bit Burst Mode when using Multi-discipline Readers in PAC Mode or TAG+PIN Mode.

Key	Output
0	11110000
1	11100001
2	11010010
3	11000011
4	10110100
5	10100101
6	10010110
7	10000111
8	01111000
9	01101001
*	01011010
#	01001011

Table 2: Single Key 8-bit Burst Mode

Setting Single Key 8-bit Burst Mode

1. Press and hold down key '2' until the Reader beeps continuously.
2. Enter '018' and finish by pressing the Hash Key (#).
3. On acceptance of the change, the Status LED will change to Green.
4. If the change is rejected the Status LED will change to Red.

Entering a Facility Code

A Facility Code only applies when PIN-codes are used. It is reported as part of the Wiegand code and can be used to link a set of Multi-discipline Readers to a particular Site.

A Facility Code can be entered into the Reader's memory. To set the Facility Code, do the following:

1. Press and hold down key '1' for 3 seconds. The Status LED will enter a fast flash Amber Mode.
2. Enter the Facility Code in the range 0 to 255 and finish by pressing the Hash Key (#).
3. On acceptance of the Facility Code the Status LED will briefly change to Green and the Buzzer will sound.
4. If the Facility Code is rejected the Status LED will change to Red for a longer period and the Buzzer will sound.

Power-on Self-test

The Power-on Self-test tests the RAM and Flash Checksums.

If any parameter in the Self-test fails, the Multi-discipline Reader emits a continuous beep for 2 seconds.

When the Multi-discipline Reader passes the Self-test, it emits two short beeps, each 200 ms in duration, separated by a 200 ms inter-beep pause.

When the Multi-discipline Reader is connected, check that the Status LED is illuminated Red (steady). This will confirm that the connection is correct and working.

Serial Number Label

1. Once the Multi-discipline Reader is installed, sketch a rough site plan.
2. Attach the Multi-discipline Reader's loose Serial Number Label and the Terminal or Controller's Fixed Address Label, to the sketched site plan in the position of the Multi-discipline Reader.

The Multi-discipline Reader does not have its own Fixed Address. When connected to a Terminal or Controller the Multi-discipline Reader is assigned one of the available Fixed Addresses.

The Serial Number Label identifies the type of Multi-discipline Reader, and the Fixed Address Label (shipped with the Terminal or Controller) identifies the Fixed Addresses. Both these labels should be attached to the site plan to assist in identifying the hardware once an Auto-ID is performed.

GUARANTEE OR WARRANTY

This product conforms to our Guarantee or Warranty details placed on our Web Site, to read further please go to www.impro.net.

USER NOTES

USER NOTES

USER NOTES



This manual is applicable to the ImproX Multi-discipline Readers,
MDR900-5-0-GB-05 and MDK900-5-0-GB-05.

(The last two digits of the Impro stock code indicate the issue status of the product).

MDR300-0-0-GB-01

Issue 02

May 2010

ImproX MDR\English Manuals\LATEST ISSUE\
MDRRdr-insm-en-02.docx