



IMPROX XFMpk

ImproX (XFMpk) Multi-mode 13.56 MHz Plastic Keypad Remote INSTALLATION MANUAL

SPECIFICATIONS

Working Environment	Designed to work in an indoor or outdoor environment similar to IP54. The Multi-mode Remote is, therefore, sealed (potted) against water.	
Input Voltage	4.5 V DC to 5.5 V DC, polarity sensitive.	
Typical Power Requirements	Current (mA)	Power (W)
Supply Voltage 5 V DC	80 to 100	0.4 to 0.5
Remote Bus Port		
Baud Rate	9 600.	
Data Format	8 Data bits, no parity, 1 stop bit.	
Electrical Interface.....	TTL full duplex.	
Communications Protocol	ImproX Proprietary Protocol.	
Keypad		
Keys	12 Alphanumeric keys.	
Buzzer		
Volume and Tone	Single tone, with a 4-step adjustable volume (including off).	
Status Indicator		
Status LED	Bi-colour Red or Green LED. Functions are application specific.	

INSTALLATION INFORMATION

Accessories

Find the following when unpacking the ImproX XFMpk:

- An ImproX (XFMpk) Multi-mode 13.56 MHz Plastic Remote housed in a Dark Grey, ABS Plastic housing. The housing consists of a Front Cover and Backing Plate secured with a Self-tapping Screw (2.2 mm x 5 mm).
- Four Brass Wood Screws (3.5 mm x 25 mm) and four Wall Plugs (7 mm).
- An extra Serial Number Label.

General

Remember the following when installing your ImproX XFMpk:

Multi-mode Remote Distance

The maximum cable distance between the Controller or Terminal and the Multi-mode Remote MUST NOT exceed 10 m (33 ft). Achieve this by using good quality screened, twisted pair cable. The cable individual conductor cross-sectional area should not be less than 0.2 mm^2 (0.0003 in^2).

Distance between Multi-mode Remotes

To avoid mutual interference Install the Multi-mode Remotes no closer than 500 mm (20 in) apart.

Mounting the Multi-mode Remote

CAUTION: Make certain that you mount the Multi-mode Remote on a vibration-free surface.

Select the mounting position of the ImproX XFMpk, considering accessibility, routing of wires and visibility of the externally visible Status LED.

Secure the Backing Plate to the mounting surface, using four suitable screws and wall plugs (supplied), nuts and bolts, rivets or double-sided adhesive tape.

Blank Space

CONNECTION INFORMATION

Typical Electrical Connections

Figure 1 to Figure 3 show typical connection diagrams for the ImproX XFMpk.

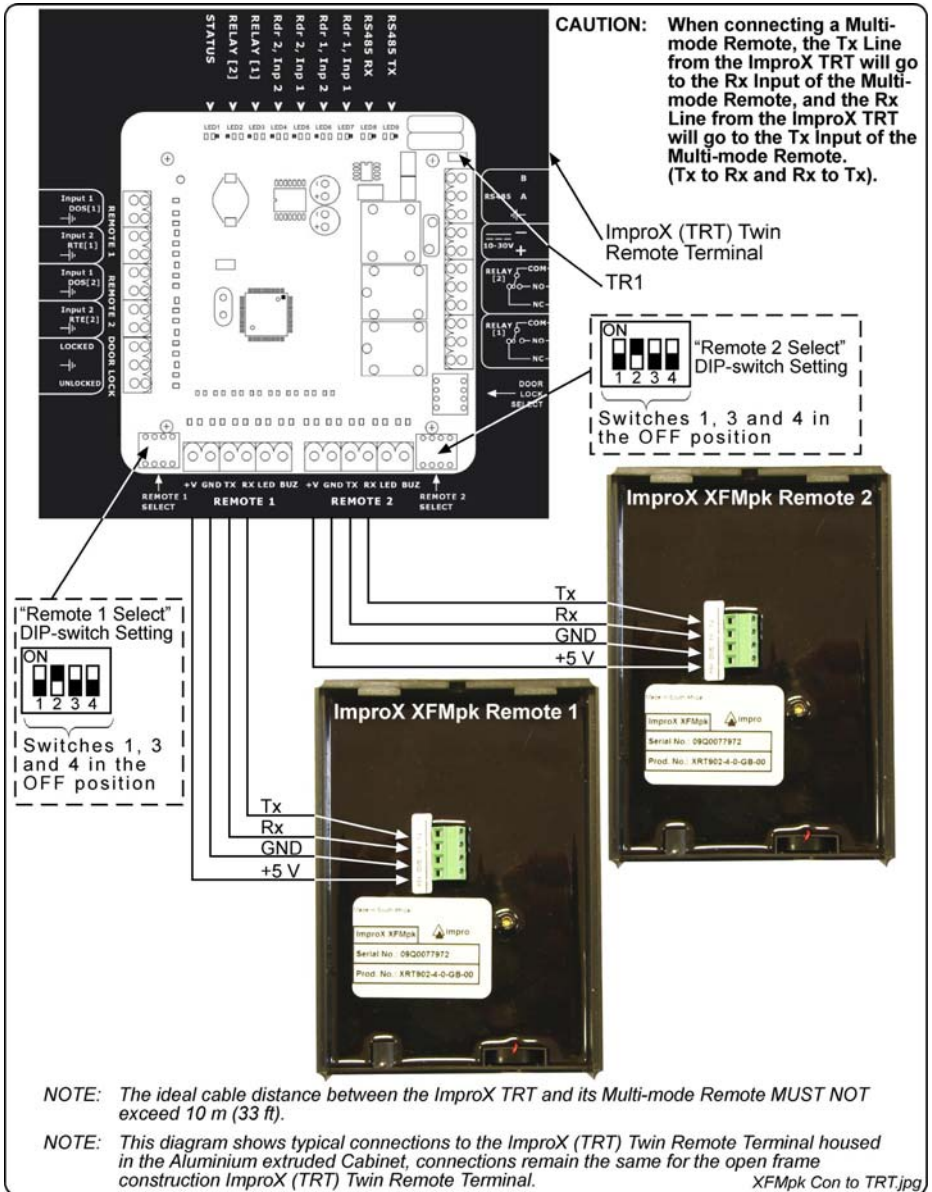

Figure 1: ImproX XFMpk Connected to the ImproX TRT

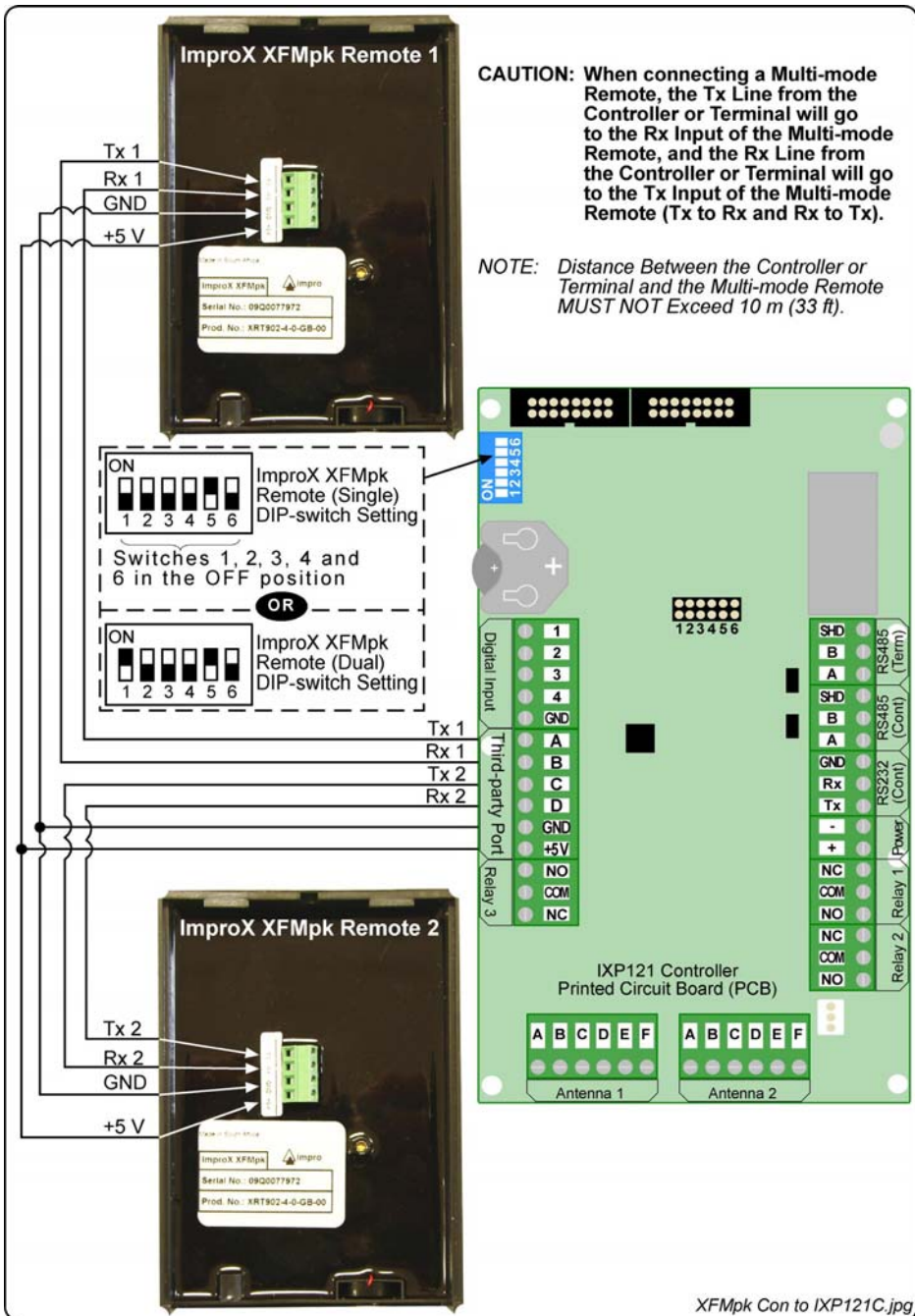

Figure 2: ImproX XFMpk Connected to the IXP121 Controller or ImproX MfT

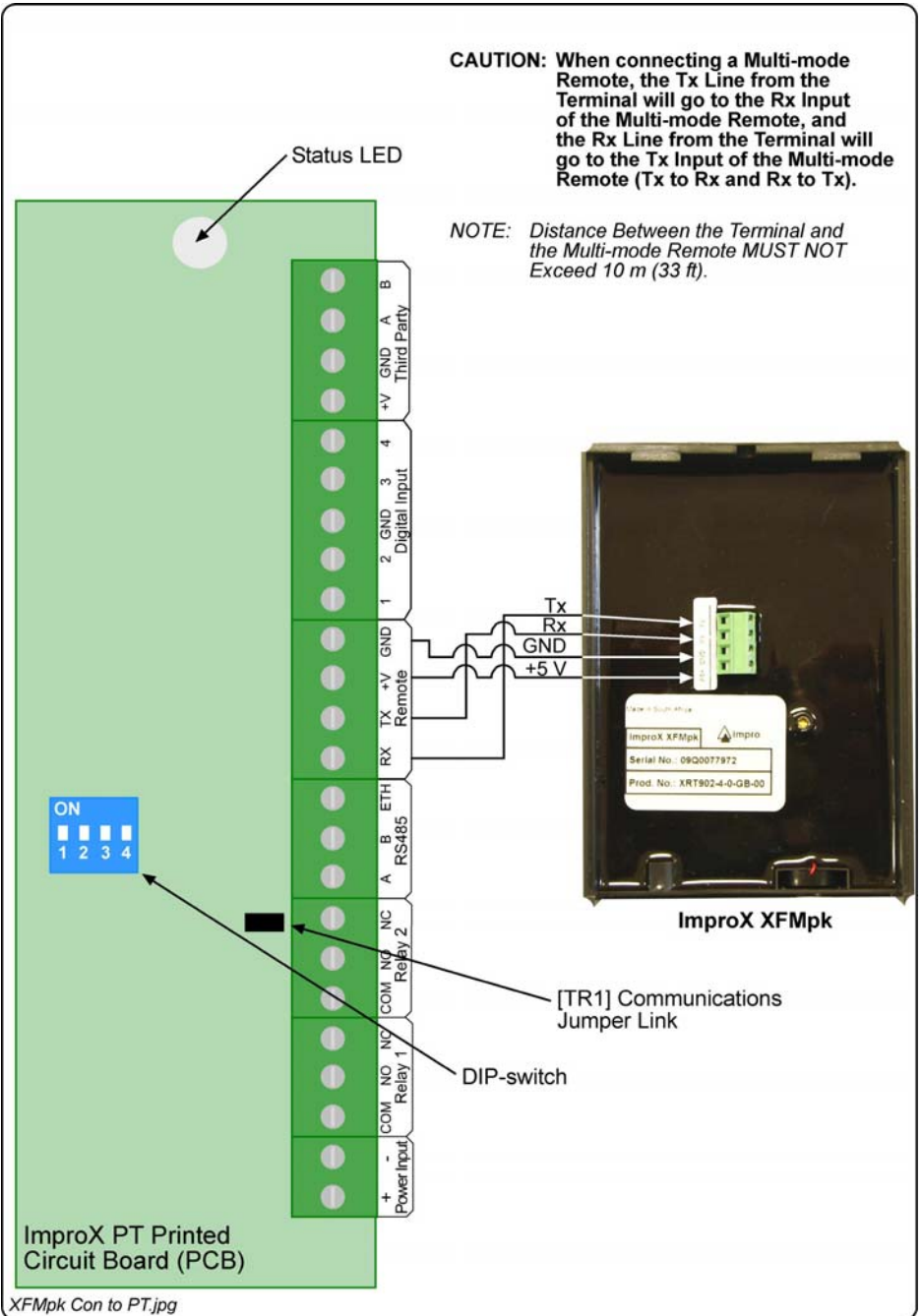

Figure 3: ImproX XFMpk Connected to the ImproX PT or ImproX TA

Power-on Self-test

The Power-on Self-test tests the RAM and Flash Checksums.

If any parameter in the Self-test fails, the Multi-mode Remote emits a continuous beep for 2 seconds.

When the Multi-mode Remote passes the Self-test, it emits two short beeps, each 200 ms in duration, separated by a 200 ms inter-beep pause.

When the Multi-mode Remote is connected, check that the Status LED is illuminated Red (steady). This will confirm that the connection is correct and working.

Serial Number Label

Once the Multi-mode Remote is installed, sketch a rough site plan. The loose Serial Number Label, packaged with the Multi-mode Remote, should be used (paired) in conjunction with the Terminal or Controllers Fixed Address Label.

The Multi-mode Remote does not have its own Fixed Address. When connected to a Terminal or Controller the Multi-mode Remote is assigned one of the available Fixed Addresses.

The Serial Number Label identifies the type of Multi-mode Remote, and the Fixed Address Label (shipped with the Terminal or Controller) identifies the Fixed Addresses. Attach both these labels to the site plan to assist in identifying the hardware when an Auto-ID is performed.

GUARANTEE OR WARRANTY

This product conforms to our Guarantee or Warranty details placed on our Web Site, to read further please go to www.impro.net.

USER NOTES

USER NOTES

USER NOTES

This manual is applicable to the ImproX (XFMpk) Multi-mode 13.56 MHz Plastic Keypad Remote, XRT902-4-0-GB-00. (The last two digits of the Impro stock code indicate the issue status of the product).

XRT302-0-0-GB-01	Issue 02	Feb 2007	ImproX XFM\ImproX XFMpk\English Manuals\ LATEST ISSUE\XFMpk-insm-en-02.doc
------------------	----------	----------	---