



MODEL NUMBER:

IPS900-0-0-GB-XX IPS910-1-0-GB-XX
IPS920-0-0-GB-XX IPS930-1-0-GB-XX
IPS940-1-0-GB-XX IPS950-1-0-GB-XX
IPS970-0-0-GB-XX IPS971-0-0-GB-XX

IMPROX IPS

ImproX (IPS) Integrated Power Supply INSTALLATION MANUAL

SPECIFICATIONS

Working Environment Designed to work in an indoor (dry) environment similar to IP20. The ImproX IPS is, therefore, not sealed against water.

Power Input

Input Voltage 85 V AC to 265 V AC at 50/60 Hz.

Power Output

IPS900 – 970 Series

Output Voltage

Mains Power On 13.8 V DC \pm 0.3 V DC.

Output Current 2 A continuous (Power Output Terminals).

Battery

IPS900 – IPS950 Series

Battery Type 12 V Sealed Lead Acid, 7 Ahr (Max).

Approximate Size

Length 151 mm (6 in) (Max).

Width 65 mm (3 in) (Max).

Height 99 mm (4 in) (Including the Terminals) (Max).

Charge Voltage 13.8 V DC.

CAUTION: Ensure that you use a 6 V rated battery with the IPS970 series.

IPS970 Series

Battery Type 6 V Sealed Lead Acid Battery, 7 Ahr (Max).

Approximate Size

Length 151 mm (6 in) (Max).

Width 65 mm (3 in) (Max).

Height 99 mm (4 in) (Including the Terminals) (Max).

INSTALLATION INFORMATION

Accessories

Find the following when unpacking the ImproX IPS:

- An ImproX Integrated Power Supply housed in a Black Mild Steel, powder-coated Cabinet. The Cabinet consists of a hinged Lid and a Base.
- An Earth Strap with Ring Terminal.

CAUTION: DO NOT use the Metal-oxide Varistors (25 Vrms, 500 A, 77 V max clamping) with mains power applications.

- IPS900 – IPS950 Series includes three Metal-Oxide Varistors, 25 Vrms, 500 A, 77 V max clamping.
- IPS970 Series includes a 3 V, CR2032, Lithium Cell Battery.
- Four Combi Screws (4 mm x 10 mm).
- Four Wood Screws (3.5 mm x 25 mm).
- Four Wall Plugs (7 mm).
- An extra Fixed Address Label.
- IPS970 Series includes a MAC Address Label.

General

EARTH Connection

Connect the Controller or Terminal to a good EARTH point.

1. Using the RS485 Port, connect the EARTH Lead to the SHD or ETH Terminal on the Controller or Terminal. Mains EARTH can be used, but electrical noise may exist.
2. Connect the Ring Terminal of the Earth Strap to a suitable point on the Cabinet.

Blank Space

Installing the Battery into the Cabinet

CAUTION: Ensure that you use a 6 V rated battery with the IPS970 series.

1. Open the Lid of the Cabinet.
2. Slide the Lid in an upwards direction and unhinge.
3. Place the Battery into the Cabinet with the Battery Terminals in an upwards position.
4. Connect the Red Battery Terminal Lead to the Positive Battery Terminal.
5. Connect the Black Battery Terminal Lead to the Negative Battery Terminal.
6. Re-hinging the Lid and slide it in a downwards direction.
7. Close the Lid of the Cabinet.

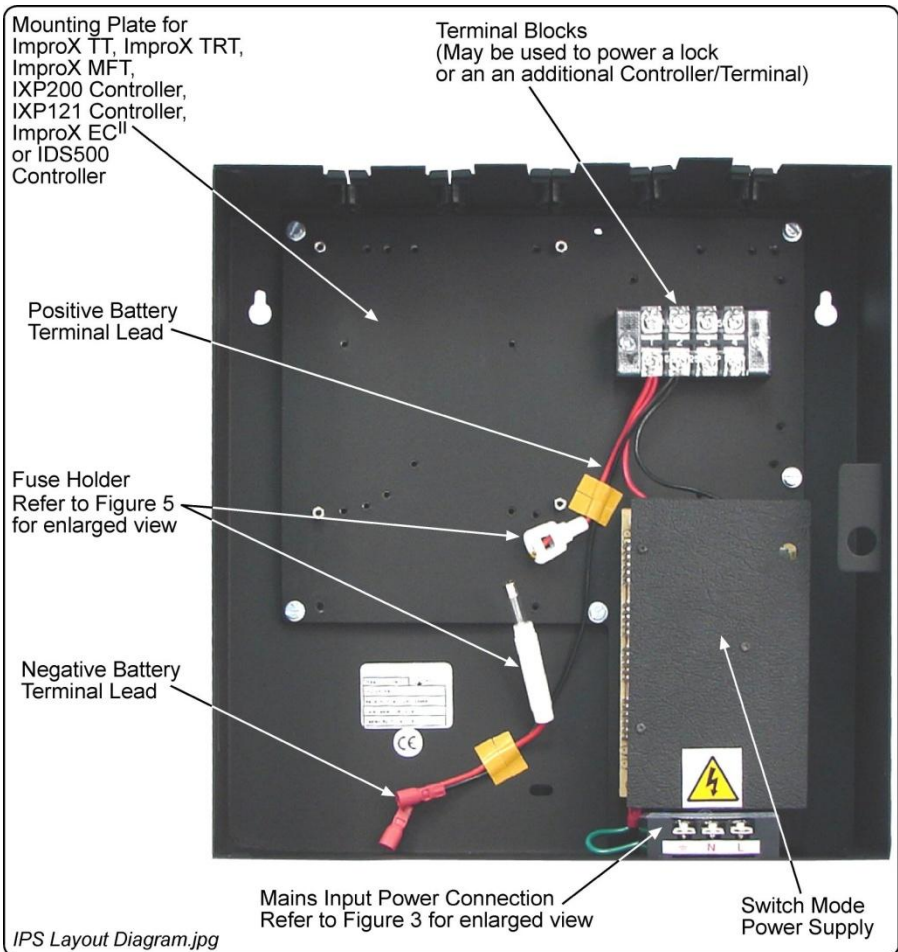

Figure 1: Layout Diagram – Top View (IPS900-0-0-GB-XX)

Mounting the Cabinet

CAUTION: Make certain that you mount the Integrated Power Supply on a vibration-free surface.

Select the mounting position of the ImproX IPS considering routing of the power wires and ventilation.

Secure the Base to the surface using three suitable screws, nuts and bolts or rivets.

Mounting the Base

1. Fix the Base against the wall using two of the supplied screws in the Mounting Keyholes.
2. Fix the third screw in the Mounting Slot, adjusting the position of the Base if necessary.

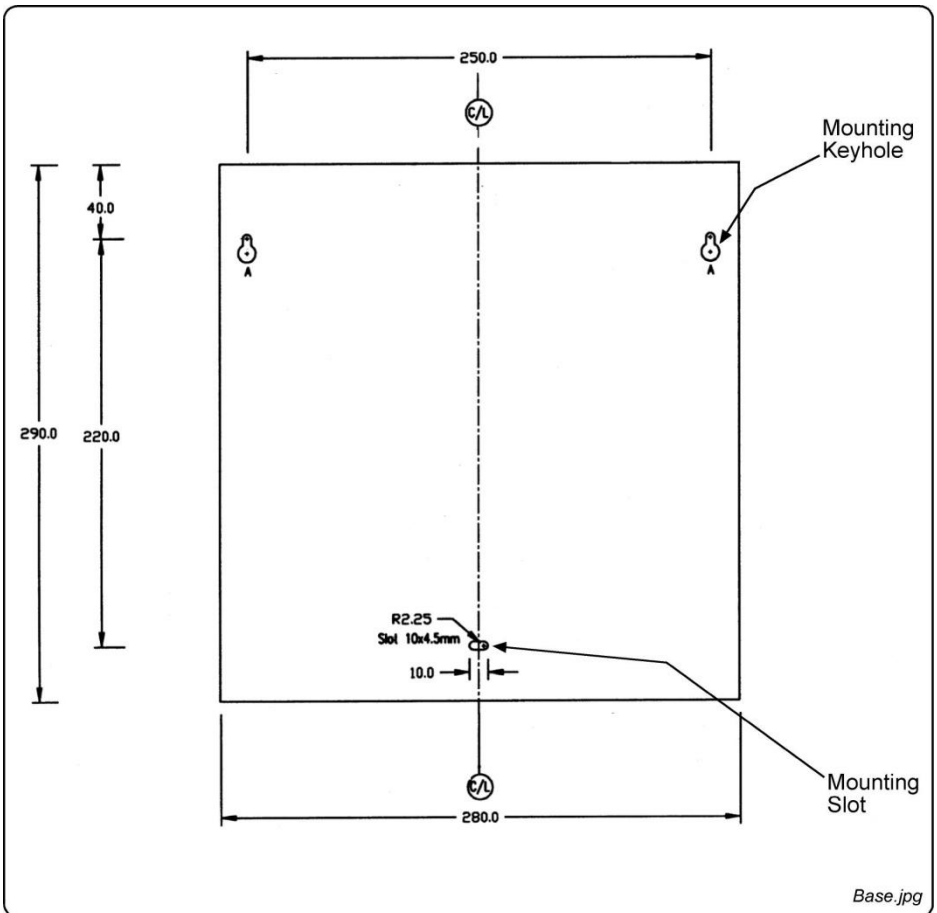

Figure 2: Base Measurements

Connecting the IPS

WARNING: BEFORE REMOVING THE PLASTIC COVER PROTECTING THE SWITCH MODE POWER SUPPLY, DISCONNECT MAINS POWER FROM THE IMPROX IPS. REMOVING THE COVER WITHOUT DISCONNECTING MAINS POWER PUTS YOU AT RISK OF ELECTRICAL SHOCK.

CAUTION: DO NOT exceed the Input Voltage specified.

Use the supplied Connection Leads for the low voltage connections to the ImproX IPS, see Figure 1.

Using the supplied Quick Click Glands or Gland Breakouts, neatly lead the wires out of the Cabinet.

Wiring the Mains Input Power Cord

WARNING: DO NOT TOUCH ANY PART OF THE CIRCUIT ONCE YOU'VE APPLIED POWER TO THE IMPROX IPS.

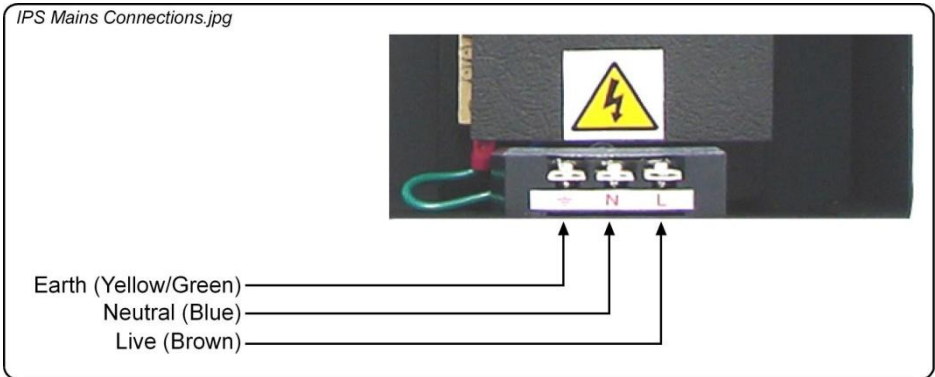

Figure 3: IPS Mains Connections

Connecting the Mains Input Power Cord

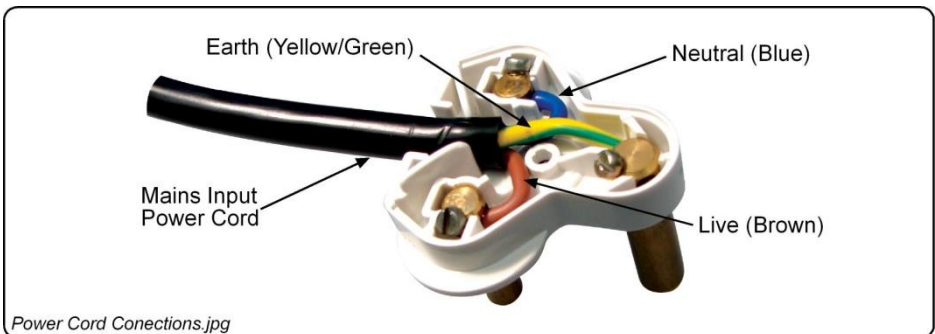

Figure 4: Mains Plug Connections

Fuse Information

Fuse Type	Purpose	Rating
Slow-blow	This fuse protects the Battery from overload as well as incorrect polarity connection.	3.15 A 250 V (6 mm x 30 mm)

Table 1: Fuse Ratings

Replacing the Fuse

CAUTION: Ensure that you have disconnected the mains power supply to the ImproX IPS, and removed the Positive Lead from the Battery before replacing the fuse.

1. Disconnect the mains power supply to the ImproX IPS.
2. Open the Cabinet.
3. Disconnect the Positive Lead from the Battery.
4. Push both ends of the Fuse Holder together, twist in opposing directions and pull apart.
5. Remove the old fuse.
6. Insert a new fuse into the longer end of the Fuse Holder.
7. Push both ends of the Fuse Holder back together and twist in opposing directions to lock.
8. Reconnect the Positive Lead to the Battery.
9. Close the Cabinet.
10. Reconnect the mains power supply to the ImproX IPS.

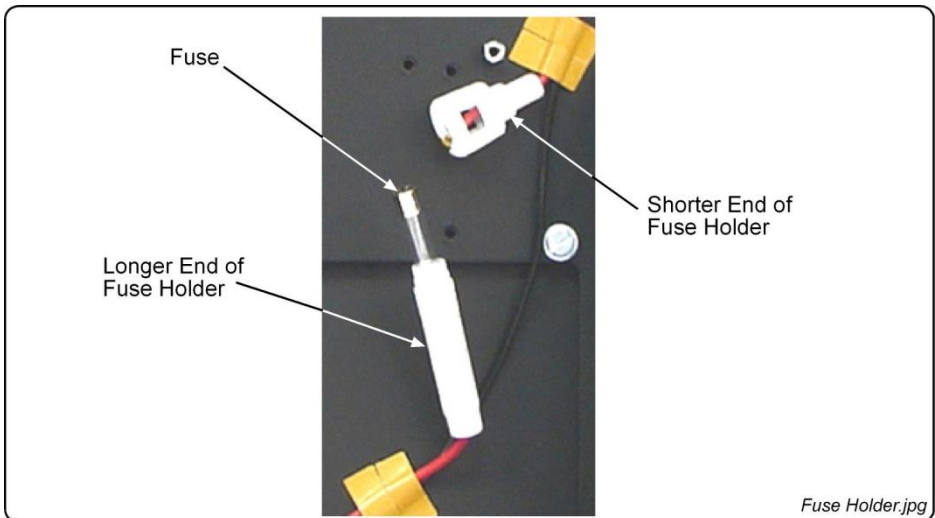

Figure 5: Fuse Holder

Serial Number Label

The loose Serial Number Label (packaged with the ImproX IPS) identifies the type of Integrated Power Supply and its Serial Number

GUARANTEE OR WARRANTY

CAUTION: We reserve the right to nullify the products guarantee or warranty where you have not properly installed the Metal-oxide Varistors.

This product conforms to our Guarantee or Warranty details placed on our Web Site, to read further please go to www.impro.net.

USER NOTES

USER NOTES

This manual applies to the ImproX (IPS) Integrated Power Supply, IPS900-0-0-GB-00, IPS910-1-0-GB-00, IPS920-0-0-GB-00, IPS930-1-0-GB-00, IPS940-1-0-GB-00, IPS950-1-0-GB-00, IPS970-0-0-GB-00 and IPS971-0-0-GB-00.

(The last two digits of the Impro stock code point to the issue status of the product).

IPS300-0-0-GB-01	Issue 02	Mar 2008	ImproX IPS\English Manuals\LATEST ISSUE\ImprXIPS-insm-en-02.docx
------------------	----------	----------	--