



MODEL: XDT900-0-0-GB-XX

ImproX DT

Door Terminal

**INSTALLATION
MANUAL**

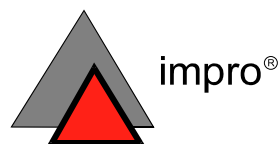

IMPORTANT NOTICE

Although all efforts have been made to make this manual as accurate as possible, Impro Technologies (Pty) Ltd does NOT accept any liability for errors or omissions. The data contained in this manual supersedes any other information published on the product. We further reserve the right to amend or improve the equipment and manual without notice.

GUARANTEE / WARRANTY

Impro Technologies (Pty) Ltd warrants that the Products furnished under this agreement will be free from material defects in material and workmanship for a period of three years from the date of shipment. The Customer shall provide notice to Impro Technologies (Pty) Ltd of each such defect within one week after the Customer's discovery of such defect. The sole obligation and liability of Impro Technologies (Pty) Ltd under this warranty shall be to repair or replace at Impro's sole discretion, but without cost to the Customer, the product or part which is so defective and as to which such notice is given.

Upon request by Impro Technologies (Pty) Ltd, the product or part claimed to be defective shall immediately be returned at the Customer's expense to Impro Technologies (Pty) Ltd. Replaced or repaired products or parts will be shipped to the Customer at the expense of Impro Technologies (Pty) Ltd.

There shall be no warranty or liability for any products or parts which have been subject to misuse, accident, negligence, failure of electric power or modification by the Customer without Impro Technologies (Pty) Ltd written approval. Final determination of warranty eligibility shall be made by Impro Technologies (Pty) Ltd. If a warranty claim is considered invalid for any reason, the Customer will be charged for services performed and expenses incurred by Impro Technologies (Pty) Ltd in handling and shipping the returned item.

As to replacement parts supplied or repairs made during the original warranty period, the warranty period of the replacement or repaired part shall terminate with the termination of the warranty period with respect to the original product or part.

As Impro Technologies (Pty) Ltd has no control over where the product is used, or how it is installed, no liability for ANY consequential damages can be accepted, whether due to malfunction, design, deficiency, implementation or any cause whatsoever.

Impro Technologies does not guarantee interfacing compatibility of any of its equipment with any third-party equipment, regardless of any standards which may be applicable. Connecting third-party equipment to any Impro equipment may compromise the functionality of the Impro equipment and render it inoperative.

THE FOREGOING WARRANTY CONSTITUTES IMPRO TECHNOLOGIES (PTY) LTD SOLE LIABILITY AND THE CUSTOMERS SOLE REMEDY WITH RESPECT TO THE PRODUCTS AND IS IN LIEU OF ALL OTHER WARRANTIES, LIABILITIES AND REMEDIES EXCEPT AS THUS PROVIDED. IMPRO TECHNOLOGIES (PTY) LTD DISCLAIMS ALL WARRANTIES, EXPRESS OR IMPLIED, INCLUDING ANY WARRANTY OF MERCHANTABILITY OR FITNESS FOR A PARTICULAR PURPOSE.

This product is designed
and manufactured by:

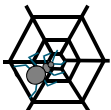

(website)
[http:// www.impro.net](http://www.impro.net)

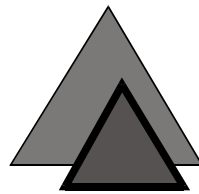

impro[®]

Technologies (Pty) Ltd
Reg. No. 90/06574/07



47 Gillitts Road
Pinetown
South Africa 3610



P O Box 15407
Westmead
South Africa 3608



(031) 700-1087
+27 31



(031) 700-1511
+27 31



(e-mail)
impro@impro.net

CONTENTS

IMPORTANT NOTICE	2
GUARANTEE/WARRANTY	2
INTRODUCTION	4
SPECIFICATIONS.....	4
PHYSICAL SPECIFICATIONS	4
ENVIRONMENTAL SPECIFICATIONS.....	4
ELECTRICAL SPECIFICATIONS.....	5
OPERATOR INTERFACES	6
IMPROX PROTOCOL.....	6
INSTALLATION INFORMATION.....	6
REQUIREMENTS	6
POSITIONING THE UNIT	6
INSTALLATION PROCEDURE	7
CONNECTING THE UNIT	8
General	8
Input Power Connections.....	8
RS485 Communications Connections	8
Remote Reader Power Connections	8
Remote Reader Communications Connections	8
Jumper Settings	8
Relay Outputs	8
BUS ACTIVITY LED INDICATORS.....	9
ADDRESS ALLOCATION	9
TYPES OF ADDRESSES	9
Fixed Address	9
Address Allocation - ImproNet Systems	9
Address Allocation - OEM Systems.....	9
RECORDING OF INSTALLATION INFORMATION	10
Installation Information	10
Entering Installation Information in the Host PC.....	12
RELATED PRODUCTS.....	12
ORDERING INFORMATION.....	13
APPLICABILITY OF THIS MANUAL	16

DIAGRAMS

Figure 1 : Relative location of significant components.....	7
Figure 2 : Connections to the DT Terminal.....	11
Figure 3 : Arc suppression circuits	12

INTRODUCTION

The Improx DT Door Terminal forms part of the ImproX family of access control equipment.

The unit provides two input sensors for door open/close sensing, and one relay for controlling door strikes or other equipment. The unit also provides 5 VDC and TTL communications for a Remote Reader such as the ImproX CR, KR, MR, KHR, MHR or connects to an Impro 4-Channel UHF Receiver.

The unit communicates with other ImproX units via an RS485 Terminal Bus connection.

The Door Terminal is intended for indoor mounting only.

SPECIFICATIONS

PHYSICAL SPECIFICATIONS

Dimensions	:	Length	=	105 mm (4.14").
		Width	=	116 mm (4.57").
		Height	=	54 mm (2.13").
Weight	:	115 g.		(4.05 oz).
Housing material	:	Aluminium.		
Colour	:	Black.		

ENVIRONMENTAL SPECIFICATIONS

TEMPERATURE

- **Operating** : -25°C to +70°C (- 13°F to +158°F).
- **Storage** : -40°C to +80°C (-40°F to +176°F).

HUMIDITY RANGE : 0 to 95% relative humidity at 40°C (+104°F) non-condensing.

EMC : EN55024.

ELECTROSTATIC DISCHARGE : IEC6 1000-4-2.

ELECTRICAL FAST TRANSIENTS : IEC6 1000-4-4.

SURGE IMMUNITY : IEC6 1000-4-5.

RADIATED SUSCEPTIBILITY : IEC6 1000-4-3.

CONDUCTED SUSCEPTIBILITY : IEC6 1000-4-6.

DUST AND SPLASH RESISTANCE : This unit is manufactured in accordance with a dust and splash environment similar to that required for a rating of IP30.

DROP ENDURANCE : 1 m drop (in packaging).

ELECTRICAL SPECIFICATIONS

POWER REQUIREMENTS

- **Voltage** : 8 V to 36 V DC.
- **Current** : 90 mA at 8V – relay and indicators all off, with a Remote Reader attached.
170 mA at 8 V – relay and indicators all on, with a Remote Reader attached.

NOTE : *The various Remote Readers draw different amounts of current. These figures represent the maximum current drawn based on the currently available Remote Readers.*

- **Permissible input supply ripple voltage (maximum)** : 1 V_{pp} 50 Hz.

POWER INPUT PROTECTION : Reverse polarity and over-voltage protection.

RELAYS : A single relay is provided.

DIGITAL INPUTS

- **Type** : 2 x dry contact inputs.
- **Protection Range** : +80 V and –80 V single pulse.
+36 V and –30 V continuous.

RELAY OUTPUT : SPDT; N/O, N/C and Common contacts.

RELAY CONTACT RATINGS : 10 A at 28 V DC.
5 A at 220 V AC.

ANTI-TAMPER SWITCH : Detects the opening of the unit enclosure.

RAM : 2 Kbytes.

FLASH ROM : 128 Kbytes.

EEPROM : 2 Kbits.

TERMINAL BUS PORT

- **Baud rates** : 1 200, 2 400, 4 800, 9 600, 19 200, 28 800, 38 400, 57 600 and 76 800 selectable via the communications protocol.
- **Default baud rate** : Factory-set to 38 400.
- **Data format** : 8 data bits, no parity, 1 stop bit.
- **Electrical Interface** : RS485, ASCII with 16-bit CRC checking.
- **Communications protocol** : ImproX Secure Communications Protocol.
- **Default mode** : Receive (Slave Mode).

- **Authentication** : A controller authenticates information from a terminal by sending it a challenge code along with its request for information. When the terminal responds it sends back a response code. The controller then verifies that the response code is correct before acting on the information received.
- **Unit status** : Slave.

REMOTE PORT

- **Baud rates** : 9 600 (fixed).
- **Data format** : 8 data bits, no parity, 1 start and 1 stop bit.
- **Electrical Interface** : TTL.
- **Communications protocol** : ImproX Proprietary Protocol.

TEST MODES : Power-On Self-test - RAM, ROM, EEPROM.

OPERATOR INTERFACES

STATUS INDICATORS

- **Power on indicator** : Red LED (externally visible).
- **Incoming RS485 Data** : Green LED (flashing) (internally visible).
- **Outgoing RS485 Data** : Red LED (flashing) (internally visible).

IMPROX PROTOCOL

The unit communicates with other ImproX units via the RS485 Terminal Bus using the ImproX Secure Communications Protocol.

INSTALLATION INFORMATION

REQUIREMENTS

To install the unit the following tools are required :

- (a) A suitable electric drill and drill bits.
- (b) Suitable flat-head screwdrivers and a Phillips screwdriver.
- (c) Side-cutters.
- (d) A wire-stripper.

POSITIONING THE UNIT

The unit can be mounted on any surface. It is recommended that the surface be flat and be at least 105 mm by 116 mm in size.

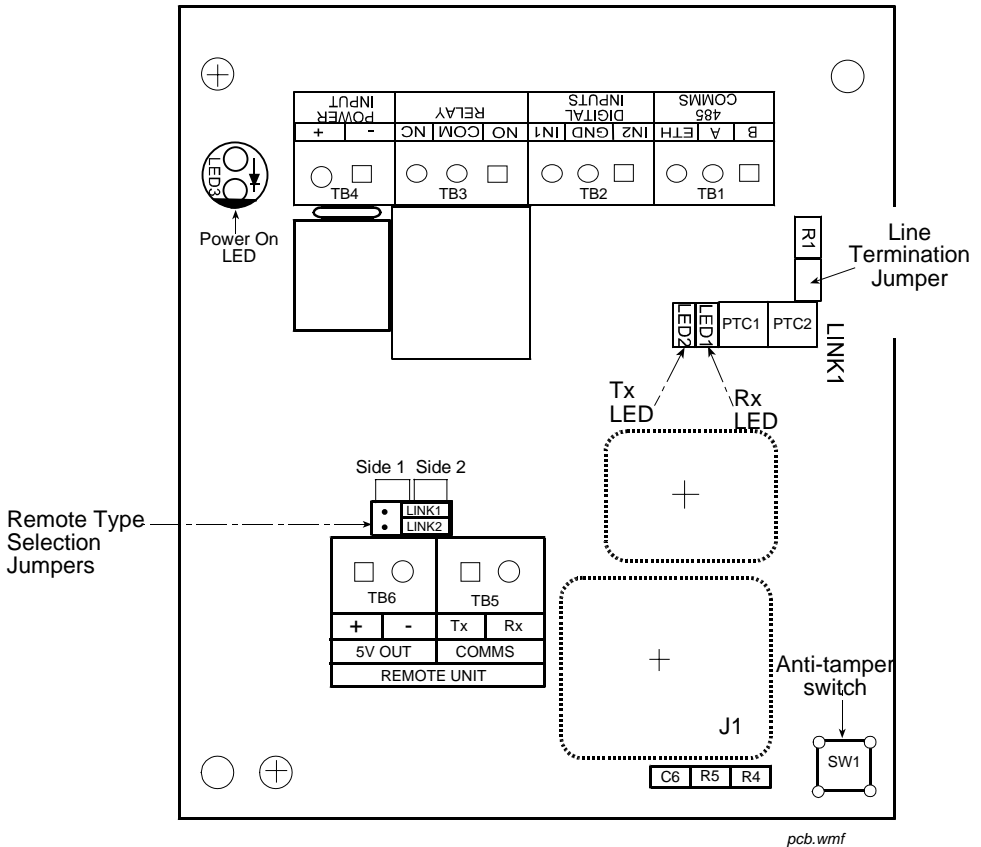

Figure 1 : Relative location of significant components

INSTALLATION PROCEDURE

- [1] Using the housing as a template, mark the position of the mounting holes on the mounting surface. Ensure that the position allows the two screws holding the lid to be removed once the unit has been mounted.
- [2] Drill the mounting holes into the mounting surface and insert wall plugs (if required).
- [3] Mount the unit to the mounting surface.
- [4] Remove the two screws holding the lid to the unit and remove the lid.
- [5] Pull the wires through the cable glands.
- [6] Connect the wires to the terminal blocks on the PCB. The required connections are described under "Connecting the Unit".
- [7] Replace the lid and hold it in place with the two screws.

CONNECTING THE UNIT

General

The connections to the unit are shown in Figure 2.

Input Power Connections

Power must be connected to the unit only at the terminal block labelled "POWER INPUT". This input is polarity-sensitive and must be connected as indicated on the PCB by the "+" and "-" symbols.

RS485 Communications Connections

All communications cable should be screened. The cable screen should be connected to the PCB terminal labelled "RS485 ETH", and this terminal should in turn be connected to a good EARTH ground. Connect each unit individually to ground to prevent possible ground loops.

Remote Reader Power Connections

The output power cable to the Remote Reader must be connected at the terminal blocks marked "REMOTE UNIT 5V OUT". The Remote Readers are generally polarity-sensitive, and must be connected correctly as indicated using the "+" and "-" symbols.

Remote Reader Communications Connections

When connecting the ImproX DT Terminal to a Remote Reader of types MR, KR, MHR, KHR and CR, it must be remembered that the "Tx" terminal on the ImproX DT Terminal must be connected to the "Rx" terminal on the Remote Reader, and vice versa. It is recommended that the cable screen be connected to the "Remote Unit 5V Out -" terminal at the ImproX DT Terminal, and to the "POWER -" terminal at the Remote Reader as shown in Figure 2.

For an Impro 4-Channel UHF Receiver connection, the "Remote Unit 5V Out" terminals must be connected to the 5V input of the UHF Receiver. The selected channel output from the UHF Receiver must be connected to the "Comms RX" terminal and the selected channels "GND" terminal connected to the "Remote Unit 5V Out-" at the DT.

Cable length

The recommended maximum length of the Remote Reader communications cable is 20 metres.

Jumper Settings

If the unit is the last unit at the end of the RS485 communications bus (i.e. furthest from the associated controller), and the transmission lines are long or multiple "star" connections are used, there will be a danger of reflections occurring on the communications bus and disrupting communications. To prevent this, the jumper located adjacent to the RS485 Terminal Block on the last unit in the chain must be connected.

NOTE : *This jumper must only be connected at the unit at the end of the bus, not at every unit.*

For the Remote Readers type MR, KR, MHR, KHR and CR both of the "Remote Type Selection" jumpers must be set to Side 1.

For an Impro 4-Channel UHF Receiver both jumpers must be set to Side 2.

Relay Outputs

In order to prevent damage to components, it is recommended that one of the arc-suppression techniques shown in Figure 3 be used.

BUS ACTIVITY LED INDICATORS

LED's are included in the unit to indicate bus activity as an aid to fault-finding. Green LED's are used to indicate incoming bus activity, and Red LED's to indicate outgoing bus activity; these LED's flash when data is being received or transmitted on the associated bus. The positions of the various LED's on the LED PCB are indicated in Figure 1.

ADDRESS ALLOCATION

GENERAL

An ImproX Unit Location Chart is packed with each ImproX IC LCD Keypad Controller and IL LCD Keypad Computer.

TYPES OF ADDRESSES

Each ImproX unit is allocated a unique Fixed Address at the factory. This address is stored in its memory. When the unit is installed in a system, the system allocates a separate Logical Address to the unit for communication purposes.

Fixed Address

The unit's Fixed Address is recorded on a label attached to the back of the unit. A copy of this label is attached to the packing box in which the unit is delivered, and a further copy is packed inside this box.

Address Allocation - ImproNet Systems

ImproNet systems automatically allocate Logical Addresses to units, either on initial software start-up, or on request, depending on the system configuration. Also, in a system configured for address allocation on software start-up, when the system software is started-up after adding a new unit to an existing system, a Logical Address will automatically be allocated to that unit.

Address Allocation - OEM Systems

In an OEM system, the unit Logical Addresses are allocated individually using commands available in the ImproX Secure Communications Protocol. Details of this process are described in the ImproX Secure Communications Protocol document.

RECORDING OF INSTALLATION INFORMATION

Installation Information

When any ImproX unit is received from the factory, the Fixed Address associated with that unit must be recorded by the installation personnel. This is done using a label supplied with the unit, and an ImproX Unit Location Chart (provided with every ImproX IC Controller or ImproX IL Computer). A unique description of the unit's physical location must also be recorded on the Chart. This process is described below.

- [1] Remove the loose copy of the unit address label from the packing box, and attach it to the ImproX Unit Location Chart in the "Unit Fixed Address" column.
- [2] In the "Unique Location Description" column, write a unique description of the unit's location to enable it to be clearly identified.

See next page

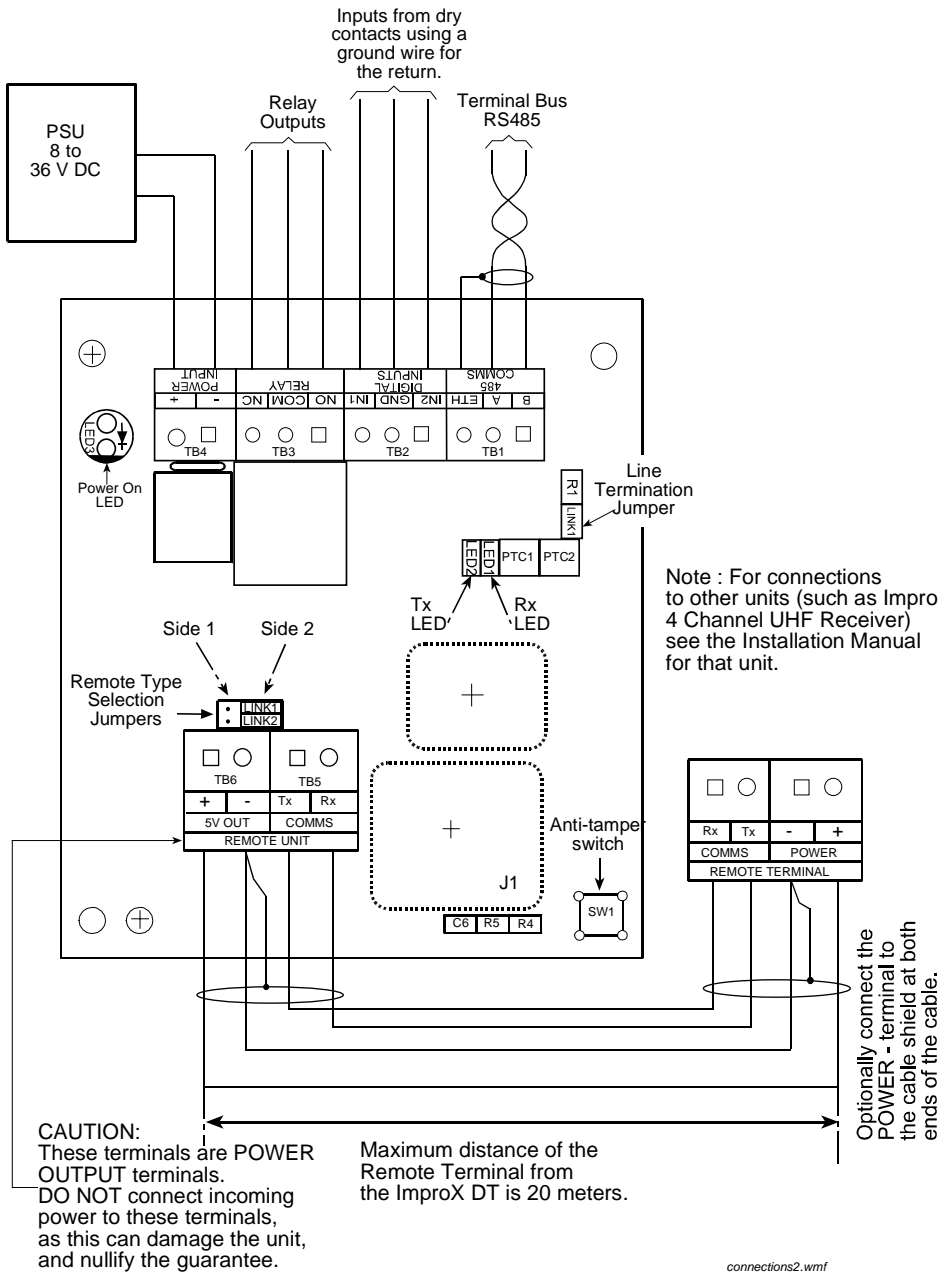

Figure 2 : Connections to the DT Terminal

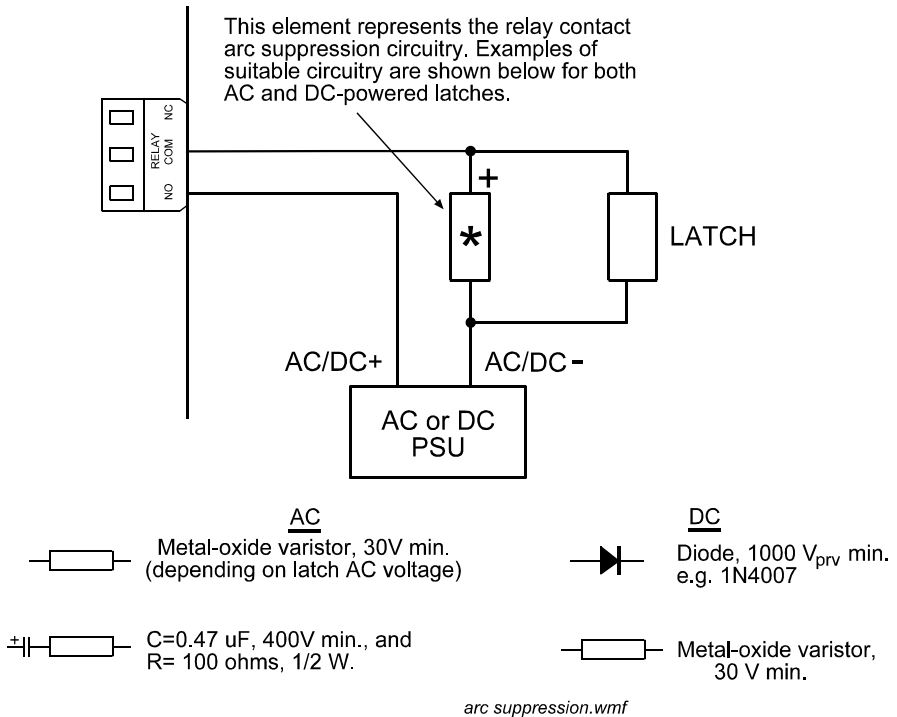

Figure 3 : Arc-suppression circuits

Entering Installation Data in the Host PC

Once information has been entered in the Unit Location Chart, the unique location description is entered into the Host PC's database.

For ImproNet Systems, details of this procedure are included in the ImproNet User Manual.

For OEM Systems, details of the appropriate procedure should be included in the system documentation. Related information for OEM programmers is included in the ImproX Secure Communications Protocol document.

Once this procedure has been completed, the Host PC will contain a record of the unit's Fixed Address, its Logical Address and a unique description of the physical location of the unit.

RELATED PRODUCTS

The ImproX DT Terminal is designed to be used in conjunction with the ImproX IL Computer and ImproX IC Controller.

Currently available Remote Readers are :

- ImproX KR Keypad Remote Reader.
- ImproX MR Micro Remote Reader.
- ImproX KHR Keypad Remote Reader (Harsh Environment).
- ImproX MHR Micro Remote Reader (Harsh Environment).
- ImproX CR Conduit Remote Reader.
- ImproX 4-Channel UHF Receiver.

This range is continually being updated. Please consult your Impro dealer for details of any additions to the range.

ORDERING INFORMATION

The ImproX DT Terminal can only be ordered paired with a Remote Reader. The ordering codes are as follows :

COMBINATION	ORDERING CODE
ImproX DT + ImproX KR	XKR900-1-0-GB-XX
ImproX DT + ImproX MR	XMR900-1-0-GB-XX
ImproX DT + ImproX KHR	XKR901-1-0-GB-XX
ImproX DT + ImproX MHR	XMR901-1-0-GB-XX
ImproX DT + ImproX CR	XCR900-1-0-GB-XX
ImproX DT + ImproX UHF	XRF900-0-1-GB-XX
ImproX DT	XDT900-0-0-GB-XX

NOTES

NOTES

NOTES

NOTES

APPLICABILITY OF THIS MANUAL

The last two digits of the standard Impro stock code indicate the issue status of the item concerned. This manual is applicable to the Door Terminal stock code XDT-900-0-0-GB-01 onwards. The next issue of this manual will determine the final equipment issue to which this manual issue is applicable.

Please advise us of any errors or omissions in this manual to enable us to improve our service to you.



Thank you for choosing *Impro* products to implement your security or asset management systems.

Impro Technologies design and manufacture a wide range of technically advanced, high-quality, reliable Access Control and Asset Identification and Management Systems. Please contact your distributor to find out more about our products, or advise us of your needs for specialised products not yet in our extensive and continually expanding range.

PATENTS AND REGISTRATIONS FOR Improx DESIGNS ARE PENDING (WORLD-WIDE).

REGISTRATION OF THE TRADEMARKS 'Improx' AND 'ImproNet' IS PENDING (WORLD-WIDE).

XDT300-0-0-GB-01

Issue 2

July 2001

k:\Custman\ Improx DT\ English Manuals\
improx_dt-insm-en-02.doc