



IXP20 CONTROLLER

ImproX IXP20 Controller INSTALLATION MANUAL

SPECIFICATIONS

Working Environment

Plastic Housing..... Designed to work in an indoor (dry) environment similar to IP40. The Controller is not sealed against water.

Power

Input Voltage..... 10 V DC to 30 V DC, polarity sensitive.

Power Requirements (ISC920) **Current (mA)** **Power (W)**

12 V DC with no peripherals connected and relays off 75 0.90

24 V DC with no peripherals connected and relays off 40 0.96

Power Requirements (ISC921)

12 V DC with no peripherals connected and relays off 130 1.56

24 V DC with no peripherals connected and relays off 60 1.44

Relay Power Requirements An additional ~0.4 W per Relay in use.

Real Time Clock (RTC) Backup Battery

Battery Type..... 1 x 3 V, CR2032, Lithium cell Battery.

Battery Life 1 year with power OFF,
5 years with power ON,
5 years storage with Battery Tab in place.

Controller Communication

Ethernet Port..... Standard Ethernet RJ45 connector.
10/100 Base T, half or full duplex.

Terminal Communication

RS485 Terminal Port

Electrical Interface.....	RS485.
Baud Rate	38 400.
Data Format	8 data bits, no parity, 1 stop bit.
Communications Protocol	ImproX Secure Communications Protocol.
Line Termination (RS485)	Provision is made for line termination.

Reader Options

Reader 1 Wiegand and Reader 2 Wiegand allows connection to the ImproX (MDR) Multi-discipline Reader and Wiegand Readers. The function is selectable via the DIP-switches (See Table 1).

Power Output	12 V DC and 5 V DC (selectable) at maximum 200 mA.
Modes Supported	Tag + PIN-code or Reason Code.
Electrical Interface	TTL Full Duplex.
Communications Protocol	ImproX Proprietary Protocol.

Relays

Relay Output	2 Relays, Form C, each with NO, COM and NC contacts.
Relay Contact Ratings	10 A at 28 V DC, 5 A at 220 V AC, 10 A at 120 V AC.
Operations	100 000 Minimum.

Digital Inputs

General

Type	4 Dry-contact inputs.
Detection Resistance Range	< 2 kOhm.
Protection Range	+15 V continuous.

Blank Space

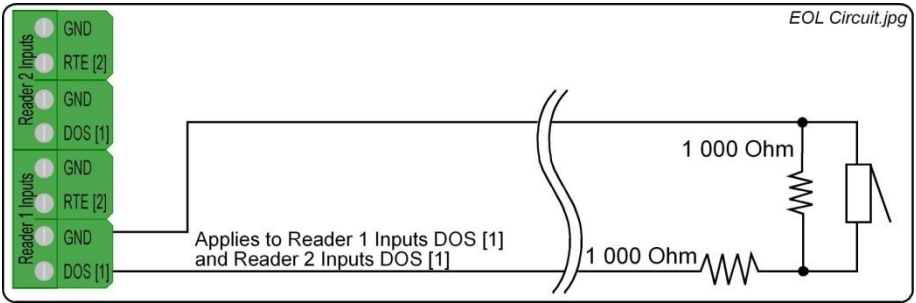

Figure 1: End of Line (EOL) Sensing Circuit

NOTE: *End of Line (EOL) Sensing enables the Controller to raise an alarm when somebody tampers with the circuit (that is, cutting or shorting the wires) between either Reader 1 Inputs DOS [1] or Reader 2 Inputs DOS [1] and GROUND (GND). In other words the Controller distinguishes between tampering on the circuit, and the door being in an actual 'Normally Open' state.*

By placing Resistors into the circuit between either Reader 1 Inputs DOS [1] or Reader 2 Inputs DOS [1] and GROUND (GND), the Controller's Digital Input monitors a constant resistance through the circuit. When the circuit is tampered with, the Resistors are bypassed; the Controller detects the resistance change raising an alarm.

Door Lock

Type 2 Dry-contact inputs.
 Protection Range +15 V continuous.

General

Frequency 125 kHz and 13.56 MHz.
 Read Capability Slim Tags, Omega Tags, Mifare® Standard, Mifare® Ultralite, FeliCa, Desfire, HID iClass, Philips HITAG™ 1 and Philips HITAG™ 2.

CAUTION: **The IXP20 System does not support the use of HID 1346 Proxkey II Tags.**

NOTE: *HID, FeliCa and MIFARE® are registered trademarks of HID Global Corporation (an ASSA ABLOY Group Brand), The Sony Corporation and Koninklijke Phillips Electronics N.V. respectively.*

Controller Diagnostic Indicators

Buzzer
 Volume and Tone Single tone, with a 3-step adjustable volume.

Display (ISC921 Only)	
Type	Thin Film Transistor Liquid Crystal Display (TFT-LCD).
Resolution.....	240 x 320 Pixels.
Colour.....	65 K Colour Screen.
Back-lighting.....	Permanently on.
Status LED	
Power On.....	Continuous Red.
Upgrade Mode.....	Flashing Red.
Incoming RS485 Data.....	Flashing Green LED.
Outgoing RS485 Data.....	Flashing Red LED.
Digital Inputs (1-4).....	Continuous Green on detected contact closure.
Relays (1 and 2).....	Continuous Red on activation of the Relay.
Locked	Continuous Green when locked.
Unlocked.....	Continuous Green when unlocked.
Enet Act (Ethernet Activity)	Flashing Red LED.
Enet Spd (Ethernet Speed)	Continuous Red for 100 Mbps (Default) Off for 10 Mbps.
Enet Lnk (Ethernet Link)	Continuous Red on connection to network.

INSTALLATION INFORMATION

Accessories

CAUTION: The IXP20 Controller needs a standard Ethernet cable to connect to a PC. We do NOT however supply this cable with the Controller's accessories.

Find the following when unpacking the ImproX IXP20 Controller:

- Either an ImproX IXP20 Twin Reader Controller with Web Interface (ISC920) supplied in a Black ABS Plastic housing. The housing consists of a Front Cover Assembly and a Mounting Plate. The Front Cover and Mounting Plate are held together with two Combi Screws (M4 x 10 mm) at the bottom of the housing.
- There are also two spare Combi Screws (M4 x 10 mm).
- Or, an ImproX IXP20 Twin Reader Controller with Touch Screen (ISC921) supplied in a Black ABS Plastic housing. The housing consists of a Front Cover Assembly and a Mounting Plate. The Front Cover and Mounting Plate are held together with two Combi Screws (M4 x 10 mm) at the bottom of the housing.
- There are also two spare Combi Screws (M4 x 10 mm).

CAUTION: DO NOT use the Metal-oxide Varistors (25 Vrms, 500 A, 77 V max clamping) with mains power applications.

- Three Metal-Oxide Varistors, 25 Vrms, 500 A, 77 V max clamping.
- A 3 V, CR2032, Lithium cell Battery.

NOTE: The 3 V, CR2032 Lithium cell Battery is partially installed in all models of the IXP20 Controller.

- An extra Fixed Address Label.

General

Remember the following when installing the IXP20 Controller:

Communications Distance

RS485 Terminal Port

The RS485 communications distance between the ImproX Controller and the LAST ImproX Terminal in a cable run, MUST NOT exceed 1 km (1 090 yd). Achieve this by using good quality screened, twisted 2-pair cable, with the screen EARTHED at one end.

Jumper Links

Long transmission lines or multiple “star” connections, may cause communication problems. Placing a Jumper Link across the jumper (See Figure 3 for position) in the LAST UNIT AT THE END OF THE CABLE RUN should solve the problem.

Distance between the Controller and its Wiegand or Multi-Discipline Readers

CAUTION: When implementing the 150 m (164 yd) cable distances with Impro Wiegand Readers use the 12 V power output option. Note, however, that the Multi-discipline Readers only connect using the 12 V power output option.

For maximum, data communications distance, install the Readers no further than 150 m (164 yd) from the Controller. The cable individual conductor cross-sectional area should not be less than 0.2 mm² (0.0003 in²).

Distance between ImproX Units

You can mount **IXP20 Controllers (ISC920)** directly next to each other. To avoid mutual interference, install the **Touch Screen IXP20 Controllers (ISC921)** at least 500 mm (20 in) apart.

To avoid mutual interference, install the **Wiegand Readers or Multi-discipline Readers** at least 500 mm (20 in) apart.

EARTH Connection

Connect the IXP20 Controller to a good EARTH point. Using the RS485 Port, connect the ETH Lead to the ‘ETH’ Terminal. Mains EARTH can be used, but electrical noise may exist.

CAUTION: When using the IXP20 Controller with FCC approved accessories, ensure that the RS485 cable is routed through a separate grommet to the power cable. Also ensure that you use a CE approved Power Supply Unit.

Blank Space

Arc Suppression

Snubber devices are recommended for EMF Flyback and Arc Suppression when driving an inductive load with the Relay, see Figure 2.

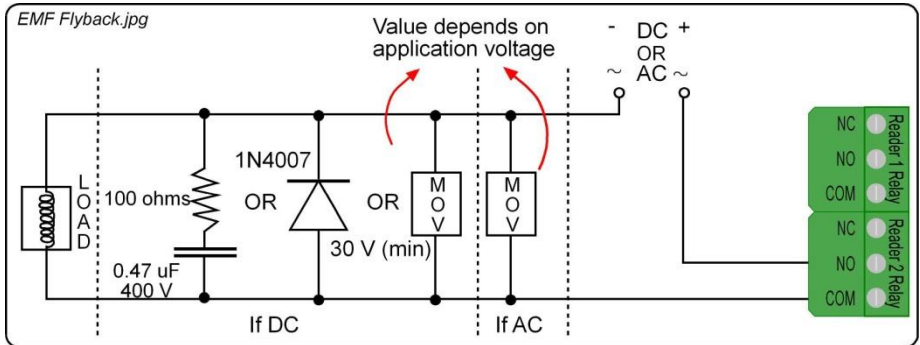

Figure 2: EMF Flyback and Arc Suppression

Installing the Real Time Clock (RTC) Backup Battery

CAUTION: Remove the Battery Tab for the Real Time Clock from the Battery Holder **IMMEDIATELY BEFORE** powering up the IXP20 Controller. **DO NOT** remove the Battery Tab after applying power to the IXP20.

First Time Use

1. Ensure that power is NOT applied to the Controller.
2. Locate the removable Battery Tab.
3. Pull the removable Battery Tab out of the Battery Holder.
4. Immediately apply power to the Controller.

Replacement

NOTE: Because of the delicacy of this procedure, we recommend you contact your distributor before trying to replace the Battery.

Mounting the IXP20 Controller

CAUTION: Make certain that you mount the Controller on a vibration-free surface.

NOTE: You can mount the IXP20 Controller onto virtually any surface including metal.

Select the mounting position of the IXP20 Controller, considering accessibility, routing of wires and visibility of the Thin Film Transistor Liquid Crystal Display (TFT-LCD) and accessibility of the Keypad.

Secure the enclosure to the mounting surface, using four suitable screws and wall plugs, nuts and bolts or rivets.

DIP-switch Settings









NOTE: Once the DIP-switch settings are modified reset the IXP20 Controller to acknowledge the new settings.

Reader 1 Select and Reader 2 Select DIP-switch Settings

Each of the Reader Ports has a 4-way DIP-switch to select the function of that Port.

NOTE: Where you have no Advanced Wiegand Readers (ImproX Multi-discipline Readers) attached, setting both Reader DIP-switches to the all off position during an Auto-ID will not return any Fixed Addresses.

NOTE: Because of the way standard Wiegand Readers handle HID Tag codes, IXP20 Sites using standard Wiegand Readers can only support one of two options: HID Tags only or other 125 kHz Tag types (such as Slim Tags, Omega Tags, Philips HITAG™ 1 and Philips HITAG™ 2 depending on the Reader). For HID Tags only, set the DIP-switch to Wiegand Open Format and the Wiegand Reader to HID Raw Mode. For any other Tag type, set the DIP-switch to Wiegand 26-bit/44-bit. For more information refer to Table 1. If you need a combination of HID Tags and other Tag types, make use of the ImproX Multi-discipline Readers.

DIP-switch Position	Connections	
0	 <p>DIP-switch 0 shows all the switches in the OFF position</p>	Advanced Wiegand Reader (ImproX Multi-discipline Readers). Full Tag codes and types.
1	 <p>DIP-switch 1 shows switches 2, 3 and 4 in the OFF position</p>	Reserved.
2		Reserved.
3		Reserved.
4		Reserved.
5		Reserved.
6		Reserved.
7		Wiegand 26-bit, 44-bit, 40-bit, 37-bit and Tag + PIN-code or Reason Code Mode.



DIP-switch Position	Connections
8 	Wiegand Open Format.
9 	If the ImproX RF is connected, then Button 1 of the ImproX (QT) Quad Transmitter reports.
10 	If the ImproX RF is connected, then Button 2 of the ImproX (QT) Quad Transmitter reports.
11 	If the ImproX RF is connected, then Button 3 of the ImproX (QT) Quad Transmitter reports.
12 	If the ImproX RF is connected, then Button 4 of the ImproX (QT) Quad Transmitter reports.

Table 1: Reader 1 Select and Reader 2 Select DIP-switch Settings

Door Lock Select DIP-switch Settings



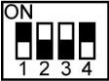
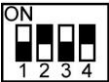

DIP-switch Position	Connections
0 	Reserved.
1 	Reserved.
2 	Reserved.
3 	Reserved.
4 	Reserved.
5 	Returns Controller to Factory Default Settings. <i>NOTE: Return Switch 1 to the OFF position to resume normal operation.</i>

Table 2: Door Lock Select DIP-switch Settings

Blank Space

Wiegand Modes

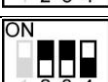
Mode	Terminal Action
Tag Only:	Treats all codes received as tag codes.
Tag + PIN:	Treats the first Wiegand code received as the tag code, and the second Wiegand code received as the PIN-code.
Tag + Reason:	Treats the first Wiegand code received as the tag code, and the second Wiegand code received as the Reason Code.

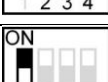
Table 3: Wiegand Modes

Wiegand Mode Rules

- Enter PIN-codes or Reason Codes on the Reader within 10 seconds otherwise the Controller discards the tag code.
- If the IXP20 Controller expects a PIN-code and receives a number greater than 65535, then the Controller assumes the number to be a tag code. The Controller discards the previously read Tag for the current one and the Controller will still expect a PIN-code.
- If the IXP20 Controller expects a Reason Code and receives a number greater than 65535, then the Controller assumes the number to be a tag code. The Controller discards the previously read Tag for the current one and the Controller will still expect a PIN-code or Reason Code, depending on the mode.
- If the Controller expects a Reason code and instead receives a number in the range 100 to 65535, the Controller assumes this is an error. The Controller discards the entire transaction, entering a new tag code starts the process again.
- If using PIN-codes and Reason Codes set the IXP20 Controller switches for Wiegand 26-bit, 37-bit, 40-bit and 44-bit, not Wiegand open format.

Blank Space

ELECTRICAL CONNECTIONS

Key Component Positions

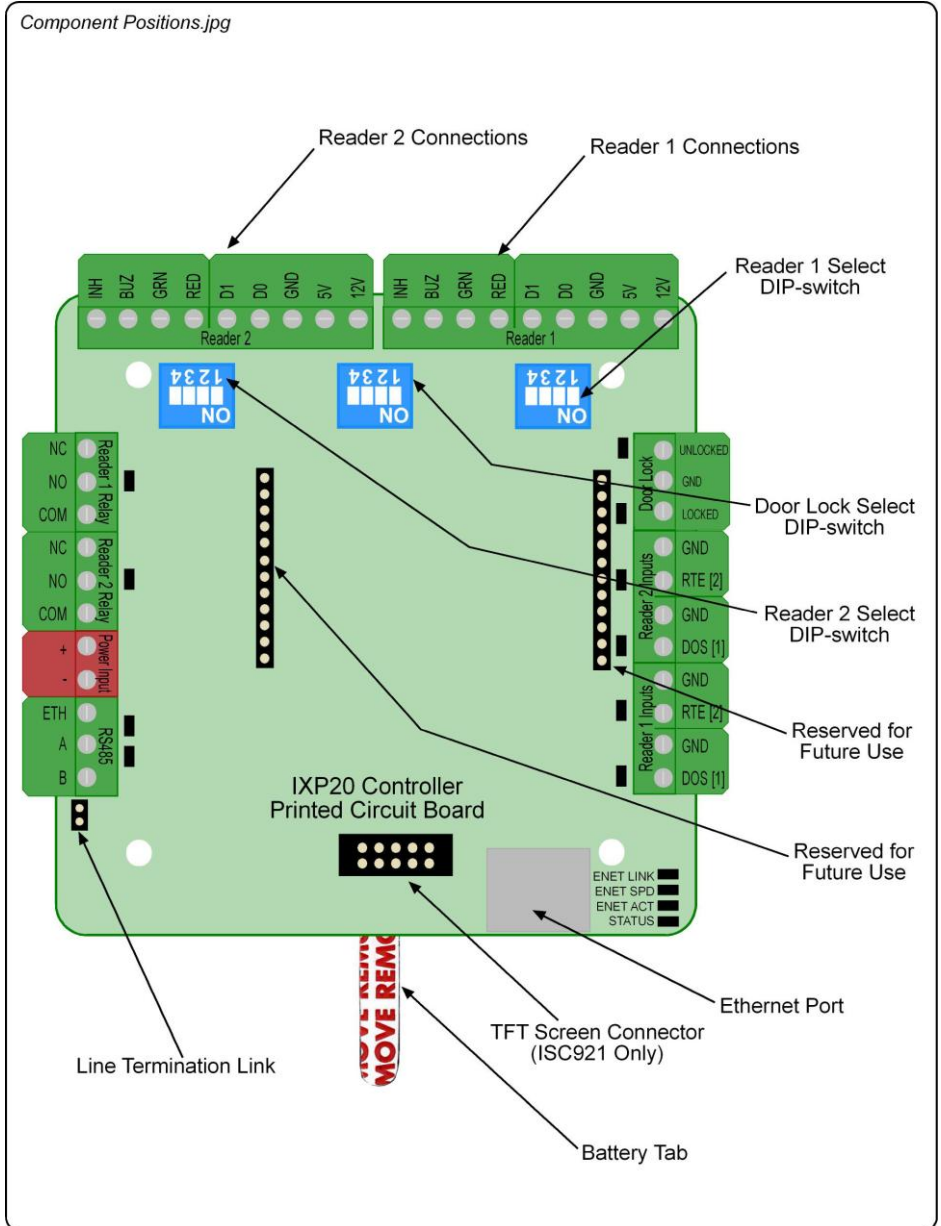

Figure 3: IXP20 Controller Key Component Positions

Connecting the IXP20 Controller

Figure 4 shows a typical electrical connection diagram for the IXP20 Controller.

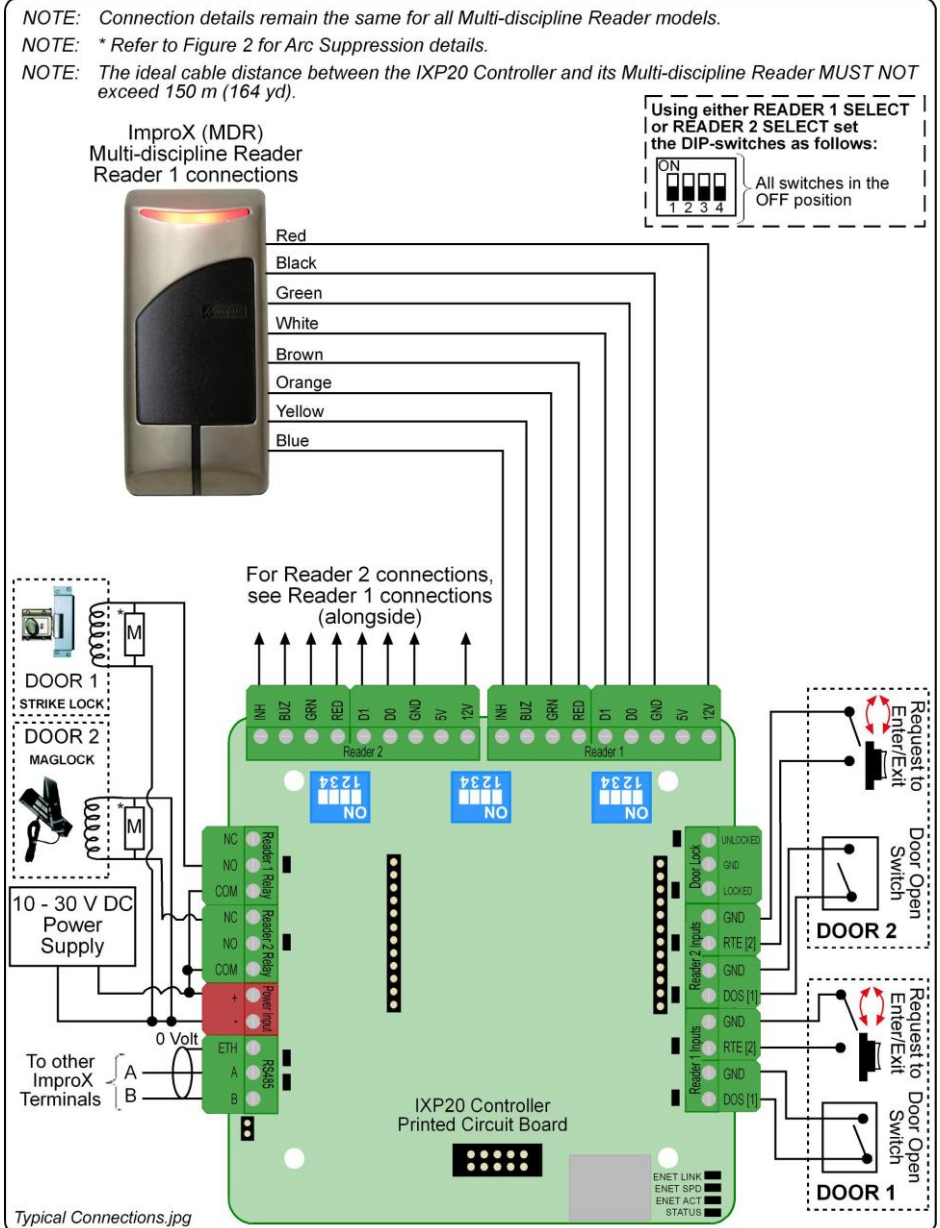

Figure 4: Typical IXP20 Controller Electrical Connections

NOTE: Connection details remain the same for all Wiegand models.

NOTE: When connecting the Wiegand Keypad Mullion Reader (WKM900) or the Wiegand Junction Box Reader (WJB900), use the cable colours displayed in brackets.

NOTE: The ideal cable distance between the IXP20 Controller and its Wiegand Reader MUST NOT exceed 150 m (164 yd).

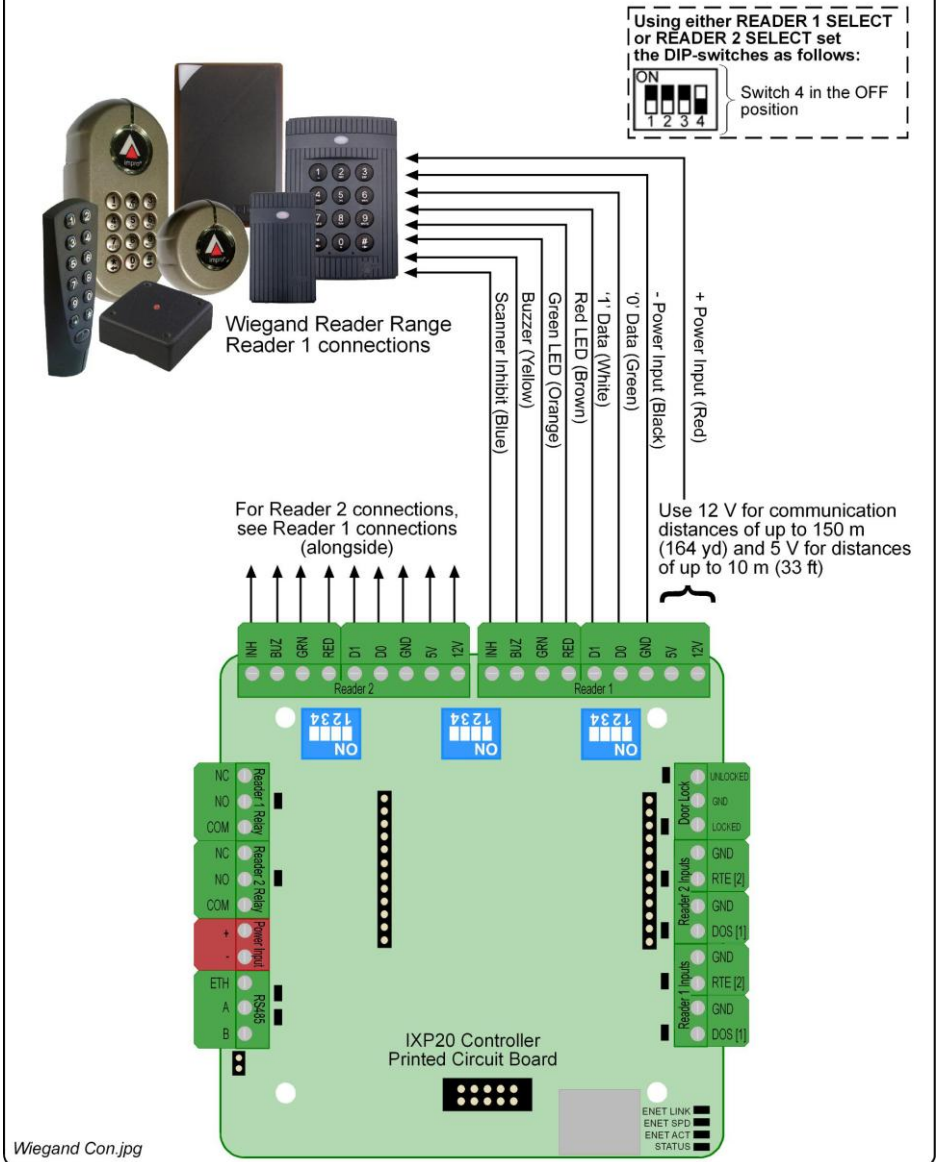

Figure 5: IXP20 Controller connected to Wiegand Reader

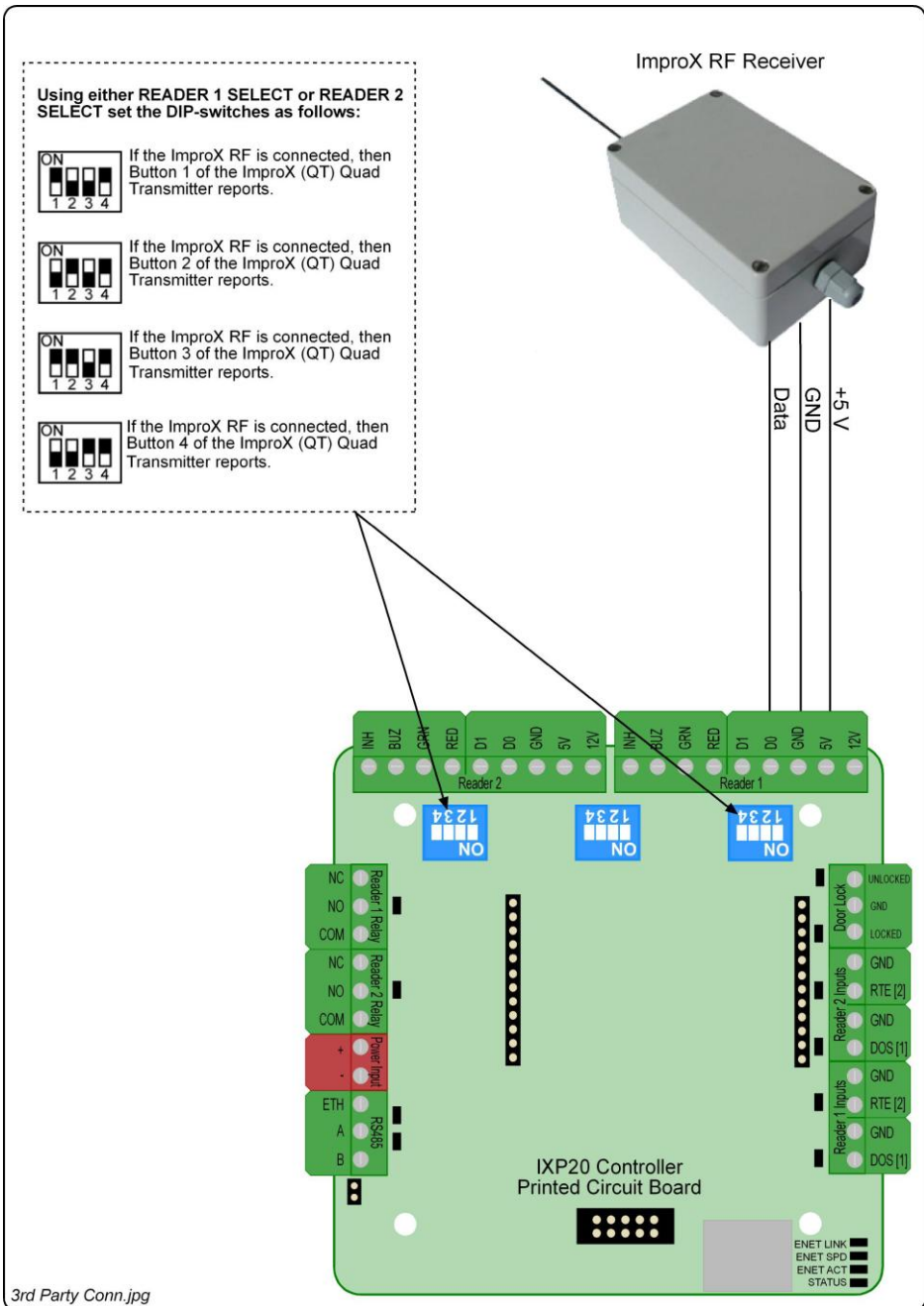

Figure 6: IXP20 Controller connected to ImproX RF

ADVANCED SETTINGS

Restoring Factory Default Settings

CAUTION: The procedures below are Controller specific. Ensure that you follow the correct procedure for your model Controller. Failure to do so results in loss of the Database.



Restore the Controller's factory default settings as follows:

ISC920

1. Remove the Controller's Front Cover Assembly.
2. Set the Door Lock Select DIP-switch Switch 1 to the ON position (see Table 2, row 5 for details).
3. Reset the Controller by removing and then reapplying the power source.
4. With the Controller running, set the Door Lock Select DIP-switch Switch 1 back to the OFF position (see Table 2, row 5 for details).
5. Reattach the Controller's Front Cover Assembly.

ISC921

CAUTION: Ensure that you return Switch 1 of the Door Lock Select DIP-switch to the OFF position. Failure to do so automatically clears the System Database on the next restart.

1. Remove the Controller's Front Cover Assembly.
2. With power applied to the Controller, toggle switch 1 of the Door Lock Select DIP-switch **ON** and then **OFF**.
3. Complete the **Action** textbox, by clicking the  button and selecting from the following:
 - **No Change**—maintains user settings.
 - **Reset Admin Password**—restores the administrator password to factory default (**12345**) without resetting the System Database.
 - **Reset System Database**—clears the Database, restoring it to factory default settings.
4. Click the  button.
5. Click the  button.
6. Reattach the Controller's Front Cover Assembly.

UNIT ADDRESS INFORMATION

Fixed Address

Once the IXP20 Controller is installed, sketch a rough site plan. Attach the loose (additional Fixed Address Label packaged with the Controller) Fixed Address Label in the position of the Controller on the sketched site plan. When the system installation is complete and all the units are represented on the site plan by their Fixed Address Labels, file the site plan for future reference.

The Fixed Address Label included with the Controller is the Fixed Address for the Controller only. In addition to the Controller Fixed Address, the IXP20 Controller reports up to two Terminal Fixed Addresses.

- Controller’s Fixed Address: 6E XX XX XX.
- Reader 1’s Fixed Address: 6F XX XX XX.
- Reader 2’s Fixed Address: 70 XX XX XX.

NOTE: *Where additional Terminals connect to the Controller, extra Fixed Addresses for the respective Terminals appear during the Software’s Auto-ID process.*

MAC Address

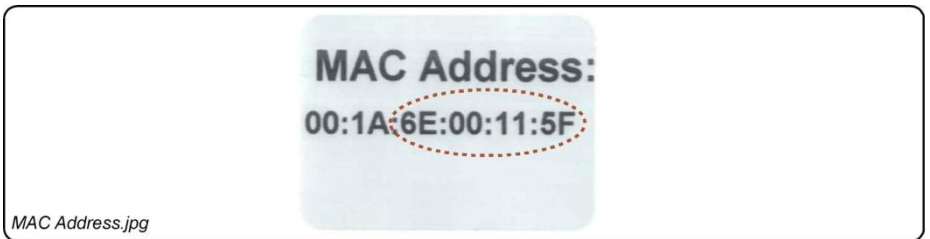

Figure 7: Sample MAC Address Label

Each IXP20 Controller is supplied with a separate MAC Address Label, much like the one shown in Figure 7, which uniquely identifies each Controller.

Attach the extra loose MAC Address Label, alongside the Fixed Address Label, to the Unit Location Chart enclosed (or your sketched site plan).

IP Address

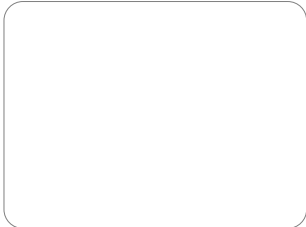

NOTE: *All ImproX IXP20 Controllers have the same IP Address (192.168.100.1). In the absence of a DHCP server, plug each Controller into the network individually and set the static IP Address.*

Unit Location Chart

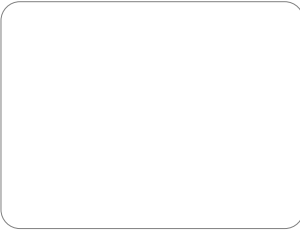
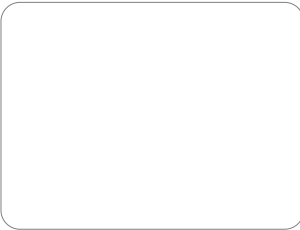
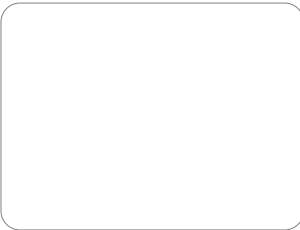
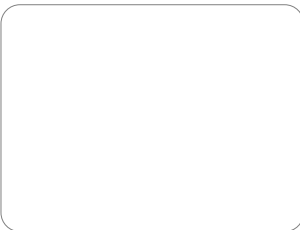
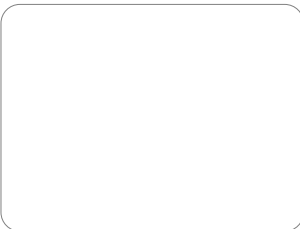
Fixed Address Label	Unique Location Description
	

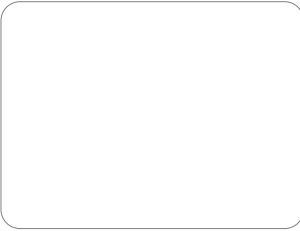
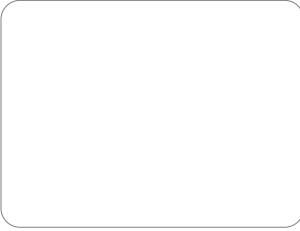
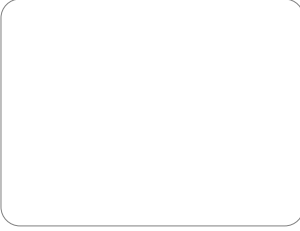
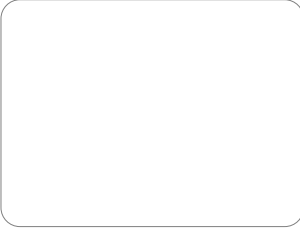
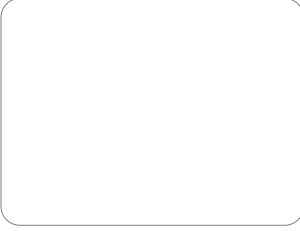
Fixed Address Label	Unique Location Description
	
	
	
	
	

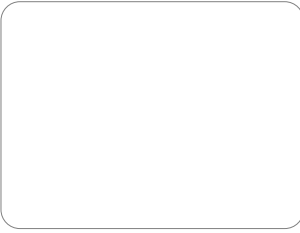
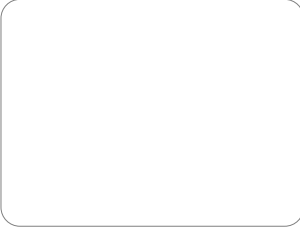
Fixed Address Label	Unique Location Description
	
	
	
	
	

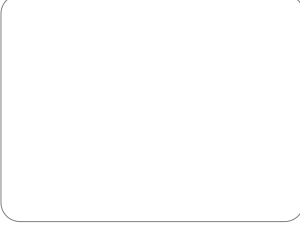
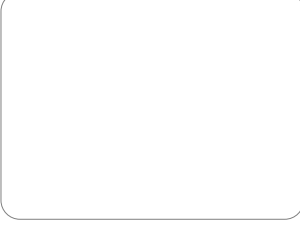
Fixed Address Label	Unique Location Description
	
	
	
	
	

Fixed Address Label	Unique Location Description
	
	

Table 4: Unit Location Chart

GUARANTEE OR WARRANTY

CAUTION: We reserve the right to nullify the products guarantee or warranty where you have not properly installed the Metal-oxide Varistors.

This product conforms to our Guarantee or Warranty details placed on our Web Site, to read further please go to www.impro.net.

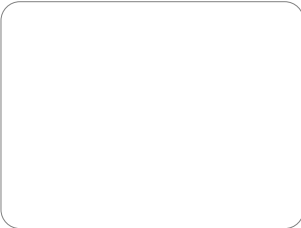
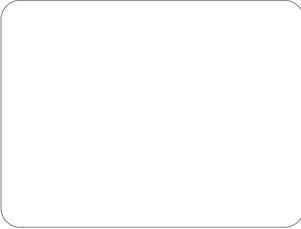
USER NOTES



This manual is applicable to the ImproX IXP20 Controller, ISC920-0-0-GB-03 and
ISC921-5-0-GB-03.

(The last two digits of the Impro stock code indicate the issue status of the product).

ISC304-0-0-GB-07

Issue 08

Jul 2011

IXP20\Controller\English Manuals\LATEST
ISSUE\ IXP20iTR-in-sm-en-08.docx