

Extension Card

Integrated Hardware Manual



Manual History

Date	Revision
February 9, 2004	First edition
April 15, 2004	DI/DO Connector Function Part Added

Contents

1. CONEXT1616 CARD	6
1.1 DI/DO CONNECTOR FUNCTION	6
1.2 HARDWARE COMPONENT	9
1.2.1 CONEXT1616 CARD PICTURE	9
1.2.2 CONEXT1616 CARD COMPONENT DESCRIPTION	10
1.3 CONEXT1616 CARD CONNECTION	11
1.3.1 HOW TO CONNECT TO CAPTURE CARD	11
1.3.2 DI/DO CONNECTION	11
2. CONEXT1200 CARD	12
2.1 DI CONNECTOR FUNCTION	12
2.2 HARDWARE COMPONENT	15
2.2.1 CONEXT1200 CARD PICTURE	15
2.2.2 CONEXT1200 CARD COMPONENT DESCRIPTION	16
2.3. CONEXT1200 CARD CONNECTION	16
2.3.1 HOW TO CONNECT TO CAPTURE CARD	17
2.3.2 DI CONNECTION	17
3. CONEXT0012 CARD	18
3.1 DO CONNECTOR FUNCTION	18
3.2 HARDWARE COMPONENT	18
3.2.1 CONEXT0012 CARD PICTURE	18
3.2.2 CONEXT0012 CARD COMPONENT DESCRIPTION	19
3.3 CONEXT0012 CARD CONNECTION	20
3.3.1 HOW TO CONNECT TO CAPTURE CARD	20
3.3.2 DO CONNECTION	20
4. CONEXT1604 CARD	21
4.1 DI/DO CONNECTOR FUNCTION	21

4.2 HARDWARE COMPONENT	24
4.2.1 CONEXT1604 CARD PICTURE.....	24
4.2.2 CONEXT1604 CARD COMPONENT DESCRIPTION	25
4.3 CONEXT1604 CARD CONNECTION.....	26
4.3.1 HOW TO CONNECT TO CAPTURE CARD	26
4.3.2 RS485/422 DEVICE CONNECTION	26
4.3.3 CONNECTION FOR RS485/422 DEVICE SIGNAL CABLE	27
4.3.4 DI/DO CONNECTION	27
4.4 REFERENCE	28
4.4.1 TERMINAL REGISTER.....	28
4.4.2 RS485/422 CONNECTOR FUNCTION	29
5. CONEXT0404 CARD	30
5.1 DI/DO CONNECTOR FUNCTION	30
5.2 HARDWARE COMPONENT	33
5.2.1 CONEXT0404 CARD PICTURE.....	33
5.2.2 CONEXT0404 CARD COMPONENT DESCRIPTION	34
5.3 CONEXT0404 CARD CONNECTION.....	35
5.3.1 HOW TO CONNECT TO CAPTURE CARD	35
5.3.2 RS485/422 DEVICE CONNECTION	35
5.3.3 CONNECTION FOR RS485/422 DEVICE SIGNAL CABLE	35
5.3.4 DI/DO CONNECTION	36
5.4 REFERENCE	36
5.4.1 TERMINAL REGISTER.....	36
4.4.2 RS485/422 CONNECTOR FUNCTION	38

1. ConExt1616 Card

1.1 DI/DO Connector Function

1.1.1 Digital Input(DI) : for sensor input

- Number of channel : 16
- Type : Relay Type, Voltage Type

▶ Input Requirement(ON)

Voltage Type : Min : 3V, Typ : 5V, Max : 12V

Relay Type : Min : 0Ω, Max :170Ω

- ▶ Sensor input value changes according to DI Type(Voltage / Relay) & External Sensor Type (Normal Open / Normal Close). Please check the value of 0(L)/1(H) after S/W(Application) setting.

ex) For Relay Type & Normal Open Sensor, it shows on SW

Normal => 0(L), Sensor working => 1 (H)

For Relay Type & Normal Close Sensor, it shows on SW

Normal => 1(H), Sensor working => 0(L)

DI Type	External Sensor Type	Sensor	Display on S/W
Voltage Type	Normal Open	Default	1(H)
		Working	0(L)
	Normal Close	Default	0(L)
		Working	1(H)
Relay Type	Normal Open	Default	0(L)
		Working	1(H)
	Normal Close	Default	1(H)
		Working	0(L)

□ Please refer to the below for details.

1.1.2 Function Description

■ **DI Circuit**



그림 1 DI Select Switch

■ **DI Select Switch(S1)**

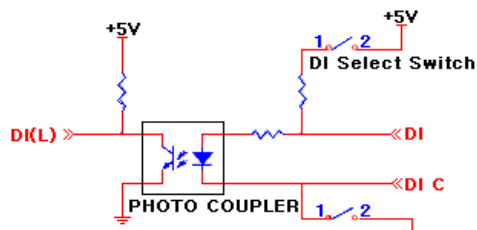

SWITCH	TYPE
ON	Relay Type
OFF	Voltage Type

■ **Relay Type**

- ▶ When the connection interface is on, "DI" is connected to "DI C." (See the Picture 1)
- ▶ Type : magnetic switch, button, relay

■ **Voltage Type**

- ▶ The power flows into DI port to make PHOTO COUPLER work. When it is on, the power inflows to DI port. (See the above Picture 1)
- ▶ Type : PNP open collector output sensor

1.1.3 Function Description for Sensor Devices

■ **Normal Open / Normal Close**

▶ **Relay Type**

Normal Open	Normal: disconnected, Working: connected
Normal Close	Normal: connected, Working: disconnected

▶ **Voltage Type**

Normal Open	Normal: 0V, Working: 5V
Normal Close	Normal: 5V, Working: 0V

- **When devices connected to sensor are Normal Open,**

- ▶ **Relay Type**

Relay Sensor	DI Value on S/W
Default	L (0)
Working	H (1)

- ▶ **Voltage Type**

Voltage Sensor	DI Value on S/W
Default	H (1)
Working	L (0)

- **When devices connected to sensor are Normal Close,**

- ▶ **Relay Type**

Relay Sensor	DI Value on S/W
Default	H (1)
Working	L (0)

- ▶ **Voltage Type**

Voltage Sensor	DI Value on S/W
Default	L (0)
Working	H (1)

1.1.4 Digital Output(DO) : for relay out

- Number of channel : 16
- Output Type : relay
- Absolute Max. Ratings of Relay : 125V, 0.5A, 30W
- Relay Type: set as Normal Open
- Default: set as OFF on S/W

1.2 Hardware Component

1.2.1 ConExt1616 Card Picture

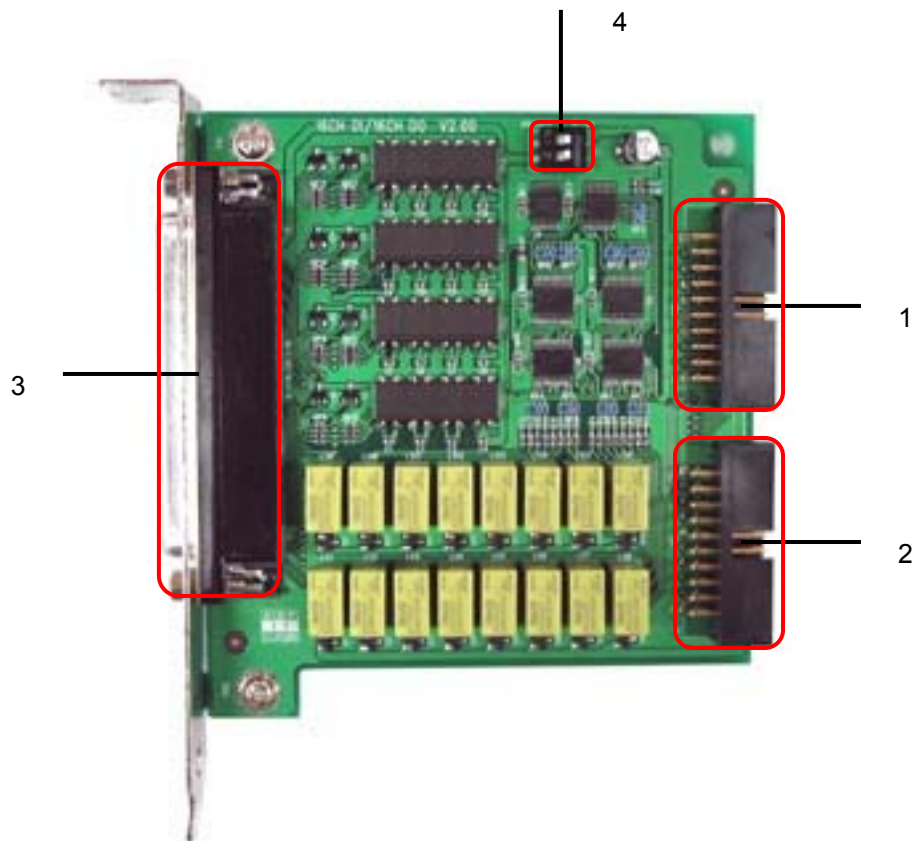

1. DIO (J2) : 20Pin Box Connector
2. DIO (J3) : 20Pin Box Connector
3. DI 1-16/DO 1-16(J1) : DSUB-37 Female Connector
4. S1 : DI Type Setting Switch

1.2.2 ConExt1616 Card Component Description

1 DIO 20Pin Box Connector (J2)

This connector is used for DI 1-16 and DO 1-16 and connected to capture card.

2 DIO 20Pin Box Connector (J3)

This is the same connector as J2 and used to connect to another extension card.

3 DI 1-16/DO 1-16(J1)

This is DSUB-37pin female connector for DI signal input from external and DO signal output to external. DI signals are transferred into No.1 ~ No.18 pin. Among the pins, No.9 and No.18 are common pins. (See the below Picture 1.) When the common pin is connected to a channel port by sensor or switch, it is possible to see the sensor or the switch ON/OFF on S/W. No.20 ~ No. 36 pin of the connector outputs DO signals. No. 28 and No. 37 are common pins. (See the Picture 1.) DO signals are controlled by S/W. When DO is turned ON, the channel port which was operated by the relay switch of capture card is connected to common port.



그림 1

4 DI Select Switch(S1)

This is a switch to select DI type. Set Switch1 and 2 to ON or OFF to select Relay Type or Voltage Type.

1.3 ConExt1616 Card Connection

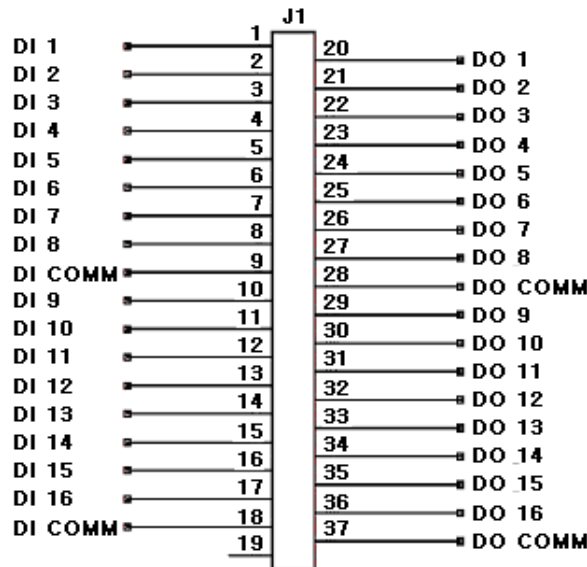
1.3.1 How to Connect to Capture Card

Connect to capture card with DIO 20Pin Connector (J2, J3). Refer the Capture Card Manual for details.

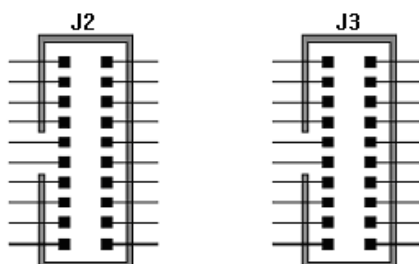

1.3.2 DI/DO Connection

DI is connected to external sensor or switch while DO to external buzzer or bell etc., both by DSUB-37Pin Female Connector (J1). See the below picture.

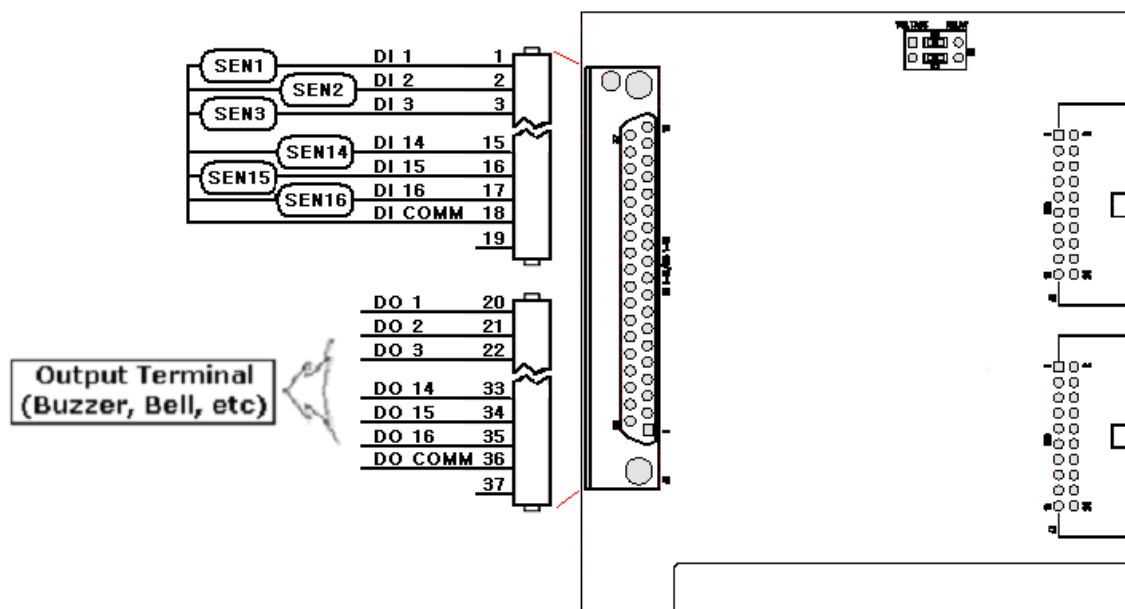

2. ConExt1200 Card

2.1 DI Connector Function

2.1.1 Digital Input(DI) : for sensor input

- Number of Channel : 12
- Type : Relay Type, Voltage Type

▶ Input Requirement(ON)

Voltage Type : Min : 3V, Typ : 5V, Max : 12V

Relay Type : Min : 0Ω, Max :170Ω

- ▶ Sensor input value changes according to DI Type(Voltage / Relay) & External Sensor Type (Normal Open / Normal Close). Please check the value of 0(L)/1(H) after S/W(Application) setting.

ex) For Relay Type & Normal Open Sensor, it shows on SW

Normal => 0(L), Sensor working => 1 (H)

For Relay Type & Normal Close Sensor, it shows on SW

Normal => 1(H), Sensor working => 0(L)

DI Type	External Sensor Type	Sensor	Display on S/W
Voltage Type	Normal Open	Default	1(H)
		Working	0(L)
	Normal Close	Default	0(L)
		Working	1(H)
Relay Type	Normal Open	Default	0(L)
		Working	1(H)
	Normal Close	Default	1(H)
		Working	0(L)

- Please refer to the below for details.

2.1.2 Function Description

■ DI Circuit



그림 1 DI Select Switch

■ DI Select Switch(S1)

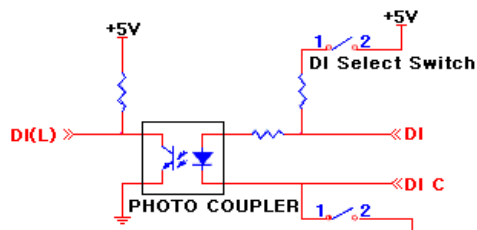

SWITCH	TYPE
ON	Relay Type
OFF	Voltage Type

■ Relay Type

- ▶ When the connection interface is on, "DI" is connected to "DI C." (See the Picture 1)
- ▶ Type : magnetic switch, button, relay

■ Voltage Type

- ▶ The power flows into DI port to make PHOTO COUPLER work. When it is on, the power inflows to DI port. (See the Picture 1)
- ▶ Type : PNP open collector output sensor

2.1.3 Function Description for Sensor Devices

■ Normal Open / Normal Close

▶ Relay Type

Normal Open	Normal: disconnected, Working: connected
Normal Close	Normal: connected, Working: disconnected

▶ Voltage Type

Normal Open	Normal: 0V, Working: 5V
Normal Close	Normal: 5V, Working: 0V

■ **When devices connected to Sensor are Normal Open,**

▶ **Relay Type**

Relay Sensor	DI Value on S/W
Default	L (0)
Working	H (1)

▶ **Voltage Type**

Voltage Sensor	DI Value on S/W
Default	H (1)
Working	L (0)

■ **When devices connected to Sensor are Normal Close,**

▶ **Relay Type**

Relay Sensor	DI Value on S/W
Default	H (1)
Working	L (0)

▶ **Voltage Type**

Voltage Sensor	DI Value on S/W
Default	L (0)
Working	H (1)

2.2 Hardware Component

2.2.1 ConExt1200 Card Picture

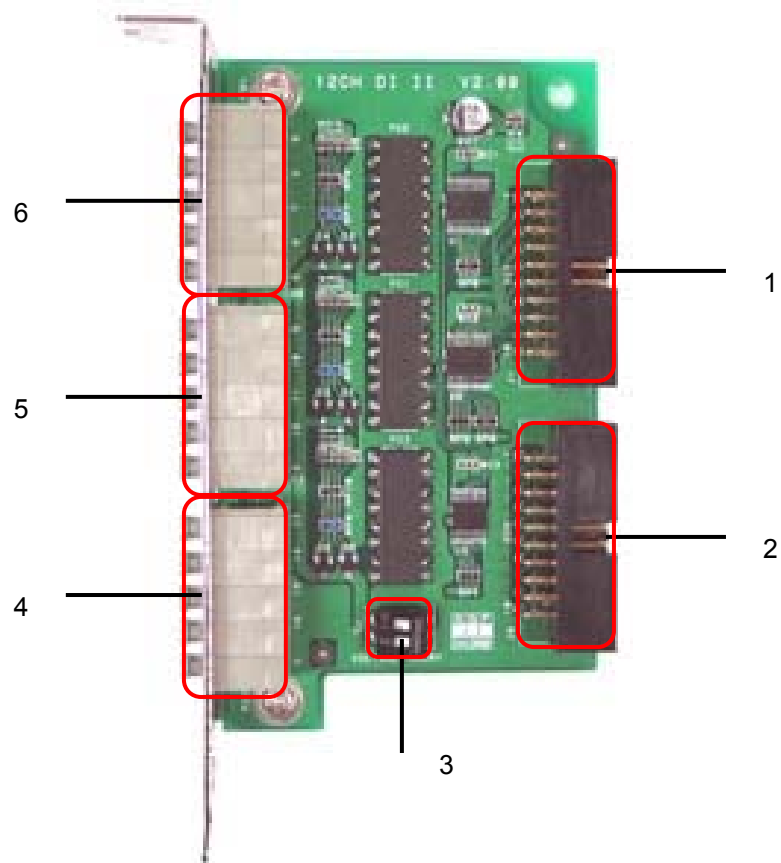

1. DIO (J1) : 20Pin Box Connector
2. DIO (J5) : 20Pin Box Connector
3. S1 : DI Type Setting Switch
4. J4 : Terminal Block for Digital Signal Input
5. J3 : Terminal Block for Digital Signal Input
6. J2 : Terminal Block for Digital Signal Input

2.2.2 ConExt1200 Card Component Description

1 DIO 20Pin Box Connector (J1)

This connector is used for DI 1-12 and connected to capture card.

2 DIO 20Pin Box Connector (J5)

This is the same connector as J1 and used to connect to another extension card.

3 DI Select Switch(S1)

This is a switch to select DI type. Set Switch1 and 2 to ON or OFF to select Relay Type or Voltage Type.

4 DI 13-16 Terminal Block(J4)

This is a connector to input DI signals from external. From the above, CH13, CH14, CH15 and CH16 are ports to input DI signals and the bottom is a common port. When the common pin is connected to a channel port by sensor or switch, it is possible to see the sensor or the switch ON/OFF on S/W.

5 DI 9-12 Terminal Block(J3)

This is a connector to input DI signals from external. From the above, CH9, CH10, CH11 and CH12 are ports to input DI signals and the bottom is a common port. When the common pin is connected to a channel port by sensor or switch, it is possible to see the sensor or the switch ON/OFF on S/W.

6 DI 5-8 Terminal Block(J2)

This is a connector to input DI signals from external. From the above, CH5, CH6, CH7 and CH8 are ports to input DI signals and the bottom is a common port. When the common pin is connected to a channel port by sensor or switch, it is possible to see the sensor or the switch ON/OFF on S/W.

2.3. ConExt1200 Card Connection

2.3.1 How to Connect to Capture Card

Connect to capture card with DIO 20Pin Connector (J1, J5). Refer the Capture Card Manual for details.

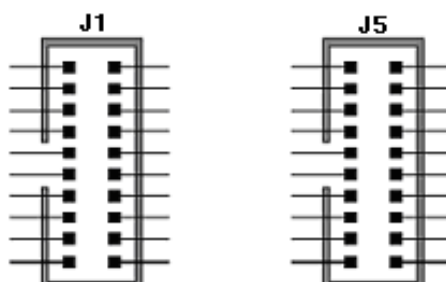

2.3.2 DI Connection

DI is connected to external sensor or switch by J2, J3, and J4 Connectors. See the below picture.

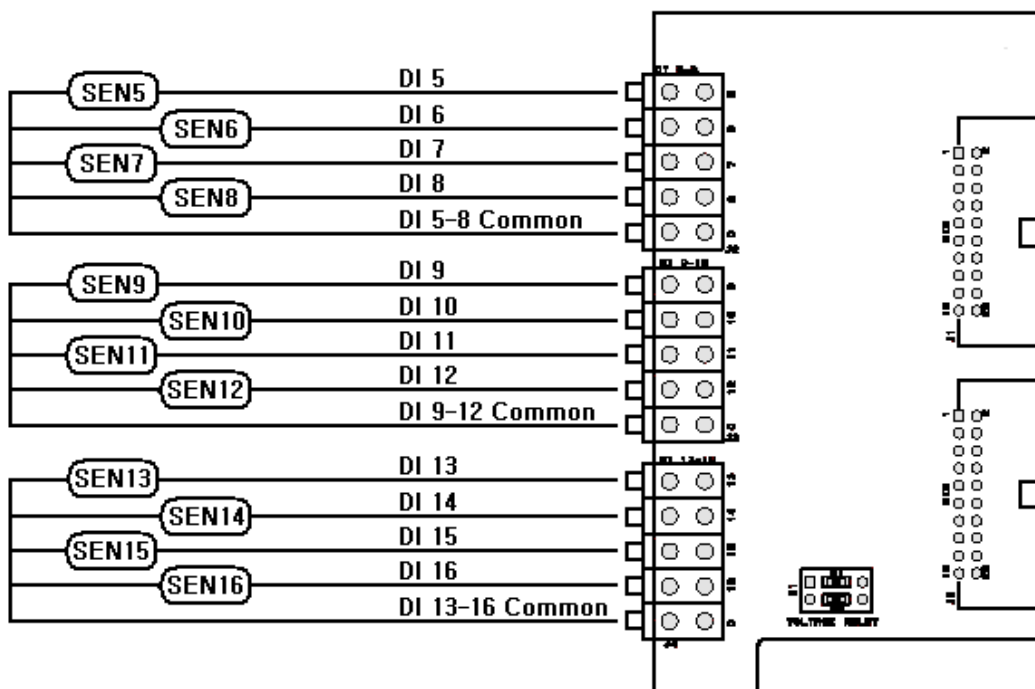

3. ConExt0012 Card

3.1 DO Connector Function

3.1.1 Digital Output(DO) : for relay out

- Number of channel : 12
- Output Type : relay
- Absolute Max. Ratings of Relay : 125V, 0.5A, 30W
- Relay Type : set as Normal Open
- Default: set as OFF on S/W

3.2 Hardware Component

3.2.1 ConExt0012 Card Picture

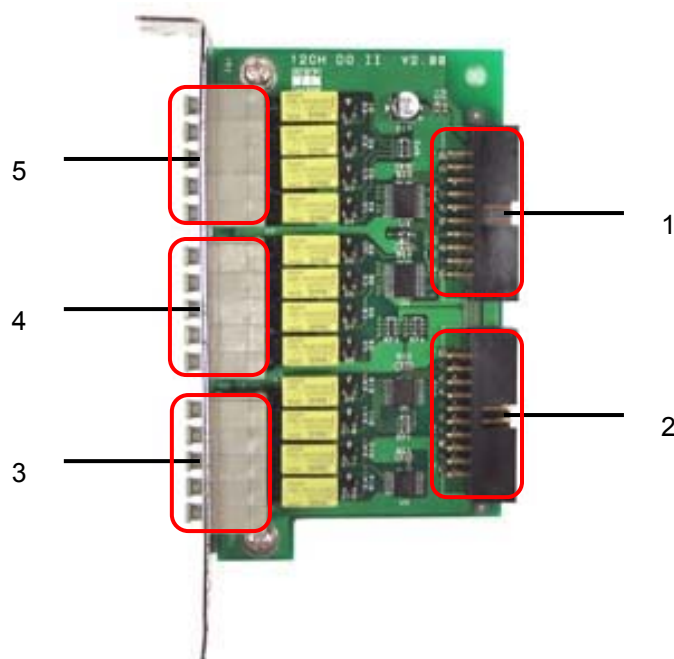

1. DIO (J1) : 20Pin Box Connector
2. DIO (J5) : 20Pin Box Connector
3. J4 : Terminal Block for Digital Signal Output
4. J3 : Terminal Block for Digital Signal Output
5. J2 : Terminal Block for Digital Signal Output

3.2.2 ConExt0012 Card Component Description

1 DIO 20Pin Box Connector (J1)

This connector is used for DO 1-12 and connected to capture card.

2 DIO 20Pin Box Connector (J5)

This is the same connector as J1 and used to connect to another extension card.

3 DO 13-16 Terminal Block(J4)

This is a connector to output DO signals to external. From the above, CH13, CH14, CH15 and CH16 are ports to output DO signals and the bottom is a common port. DO signals are controlled by S/W. When DO is turned ON, the channel port which was operated by the relay switch of capture card is connected to common port.

4 DO 9-12 Terminal Block(J3)

This is a connector to output DO signals to external. From the above, CH9, CH10, CH11 and CH12 are ports to output DO signals and the bottom is a common port. DO signals are controlled by S/W. When DO is turned ON, the channel port which was operated by the relay switch of capture card is connected to common port.

5 DO 5-8 Terminal Block(J2)

This is a connector to output DO signals to external. From the above, CH5, CH6, CH7 and CH8 are ports to output DO signals and the bottom is a common port. DO signals are controlled by S/W. When DO is turned ON, the channel port which was operated by the relay switch of capture card is connected to common port.

3.3 ConExt0012 Card Connection

3.3.1 How to Connect to Capture Card

Connect to capture card with DIO 20pin connector (J1, J5). Refer the Capture Card Manual for details.

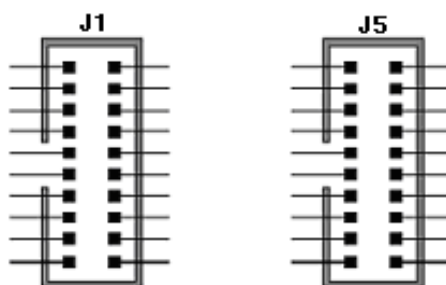

3.3.2 DO Connection

DO is connected to external buzzer or bell etc. by J2, J3 and J4 Connectors. See the below picture for details.

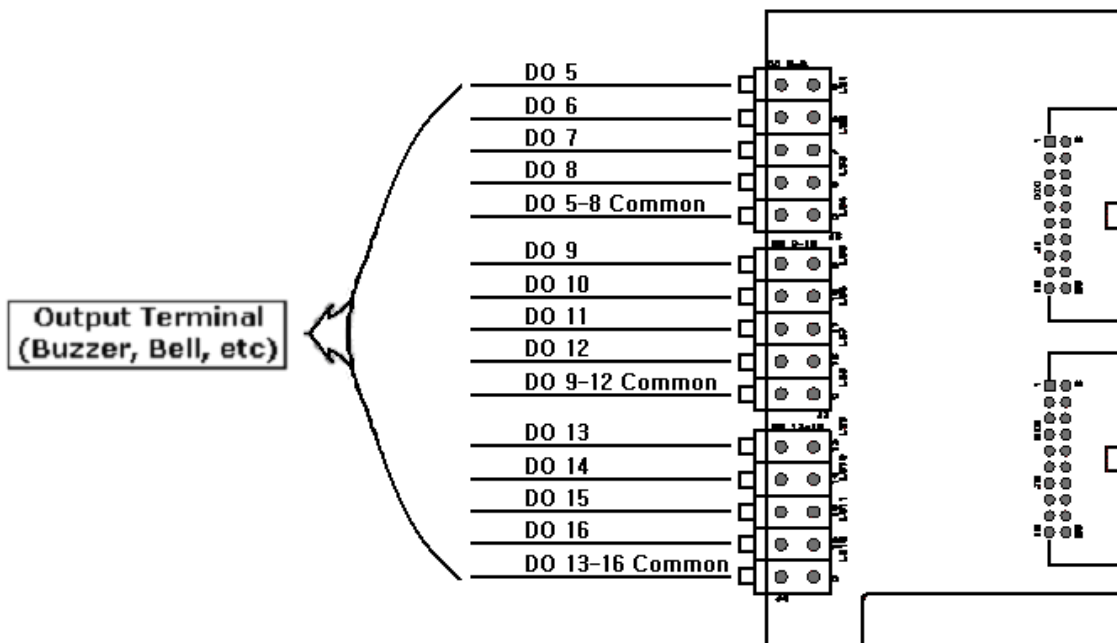

4. ConExt1604 Card

4.1 DI/DO Connector Function

4.1.1 Digital Input(DI) : for sensor input

- Number of channel : 16
- Type : Relay Type, Voltage Type

▶ Input Requirement(ON)

Voltage Type : Min : 3V, Typ : 5V, Max : 12V

Relay Type : Min : 0Ω, Max :170Ω

- ▶ Sensor input value changes according to DI Type(Voltage / Relay) & External Sensor Type (Normal Open / Normal Close). Please check the value of 0(L)/1(H) after S/W(Application) setting.

ex) For Relay Type & Normal Open Sensor, it shows on SW

Normal => 0(L), Sensor working => 1 (H)

For Relay Type & Normal Close Sensor, it shows on SW

Normal => 1(H), Sensor working => 0(L)

DI Type	External Sensor Type	Sensor	Display on S/W
Voltage Type	Normal Open	Default	1(H)
		Working	0(L)
	Normal Close	Default	0(L)
		Working	1(H)
Relay Type	Normal Open	Default	0(L)
		Working	1(H)
	Normal Close	Default	1(H)
		Working	0(L)

- Please refer to the below for details.

4.1.2 Function Description

■ **DI Circuit**



그림 1 DI Select Switch

■ **DI Select Switch(S1)**

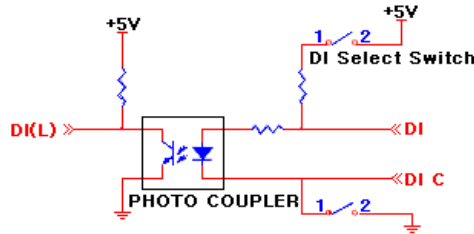
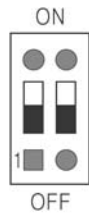

SWITCH	TYPE
ON	Relay Type
OFF	Voltage Type

■ **Relay Type**

- ▶ When the connection interface is on, "DI" is connected to "DI C." (See the Picture 1)
- ▶ Type : magnetic switch, button, relay

■ **Voltage Type**

- ▶ The power flows into DI port to make PHOTO COUPLER work. When it is on, the power inflows to DI port. (See the Picture 1)
- ▶ Type : PNP open collector output sensor

4.1.3 Function Description for Sensor Devices

■ **Normal Open / Normal Close**

▶ **Relay Type**

Normal Open	Normal: disconnected, Working: connected
Normal Close	Normal: connected, Working: disconnected

▶ **Voltage Type**

Normal Open	Normal: 0V, Working: 5V
Normal Close	Normal: 5V, Working: 0V

- **When devices connected to Sensor are Normal Open,**

▶ **Relay Type**

Relay Sensor	DI Value on S/W
Default	L (0)
Working	H (1)

▶ **Voltage Type**

Voltage Sensor	DI Value on S/W
Default	H (1)
Working	L (0)

- **When devices connected to Sensor are Normal Close,**

▶ **Relay Type**

Relay Sensor	DI Value on S/W
Default	H (1)
Working	L (0)

▶ **Voltage Type**

Voltage Sensor	DI Value on S/W
Default	L (0)
Working	H (1)

4.1.4 Digital Output(DO) : for relay out

- Number of channel : 4
- Output Type : relay
- Absolute Max. Ratings of Relay : 125V, 0.5A, 30W
- Relay Type: set as Normal Open
- Default: set as OFF on S/W

4.2 Hardware Component

4.2.1 ConExt1604 Card Picture

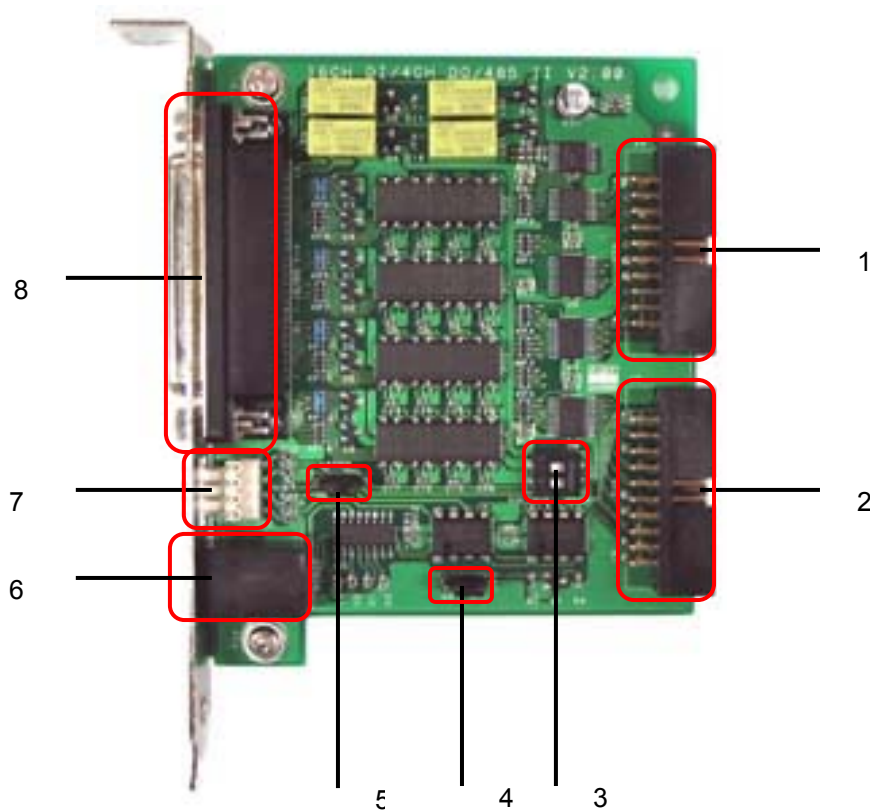

- 1. DIO (J4) : 20Pin Box Connector
- 2. DIO (J5) : 20Pin Box Connector
- 3. S1 : DI Type Setting Switch
- 4. JP2 : RS485/422 Select Jumper
- 5. JP1 : Terminal Register Select Jumper
- 6. J2 : Connector for RS232 signal cable
- 7. J1 : 4Pin Connector for RS485/422 Device
- 8. DI 1-16/DO 1-4(J3) : DSUB-25 Female Connector

4.2.2 ConExt1604 Card Component Description

1 DIO 20Pin Box Connector (J4)

This connector is used for DI 1-16 and DO 1-4 and connected to capture card.

2 DIO 20Pin Box Connector (J5)

This is the same connector as J4 and used to connect to another extension card.

3 DI Select Switch (S1)

This is a switch to select DI type. Set Switch1 and 2 to ON or OFF to select Relay Type or Voltage Type.

4 RS485/422 Select Jumper (JP2)

This is a jumper to select RS485/422 function.

5 Terminal Register Select Jumper (JP1)

This is a jumper to select 120Ω terminal register connection.
Refer to 4.4.1 Terminal Register.

6 Connector for RS232 Signal Cable (J2)

This is a connector to connect RS232 cable from external device.

7 4Pin Connector for RS485/422 Device (J1)

This connector is used to connect RS485/422 cable of external device.

8 DI 1-16/DO 1-4 (J3)

This is DSUB-25pin female connector for DI signal input from external and DO signal output to external. DI signals are transferred into No.1 ~ No.20 pin. Among the pins, No.5, No.10, No.15 and No.20 are common pins. When the common pin is connected to a channel port by sensor or switch, it is possible to see the sensor or the switch ON/OFF on S/W. No.21 ~ No.24 pins of the connector outputs DO signals. No. 25 is common pins. (See the Picture 1.) DO signals are controlled by S/W. When DO is turned ON, the channel port which was operated by the relay switch of capture card is connected to common port.



그림 1

4.3 ConExt1604 Card Connection

4.3.1 How to Connect to Capture Card

Connect to capture card with DIO 20pin connector (J4, J5). Refer the Capture Card Manual for details.

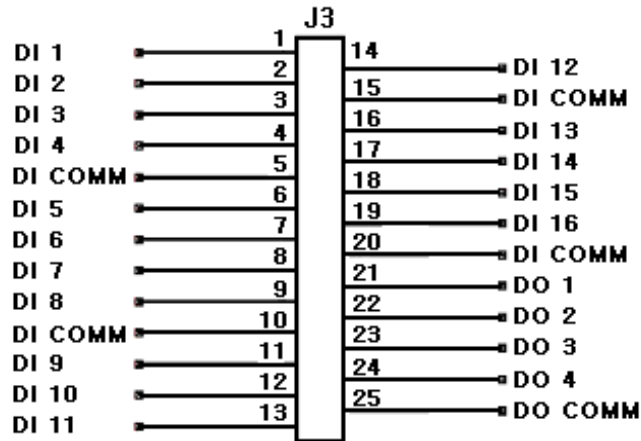
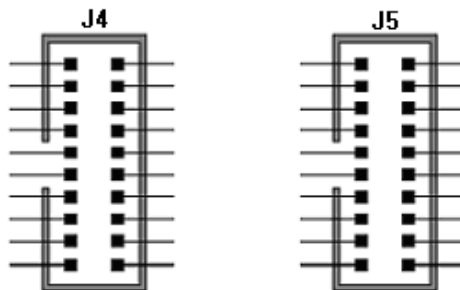

4.3.2 RS485/422 Device Connection

RS485/422 device is used for Pan/Tilt/Zoom camera control. Connect RS485/422 device to J1 with 4pin connector.

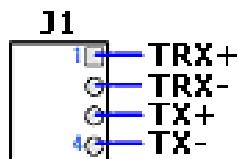

4.3.3 Connection for RS485/422 Device Signal Cable

This is connected to COM PORT of other system by RJ connector. See the below picture for the pin arrangement.

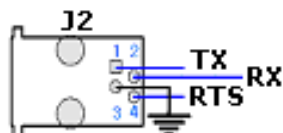

- Refer to Capture Card Manual to connect ConExt1604 Card to Capture Card.

4.3.4 DI/DO Connection

DI is connected to external sensor or switch while DO to external buzzer or bell etc., both by DSUB-25Pin Female Connector (J3). See the below picture.

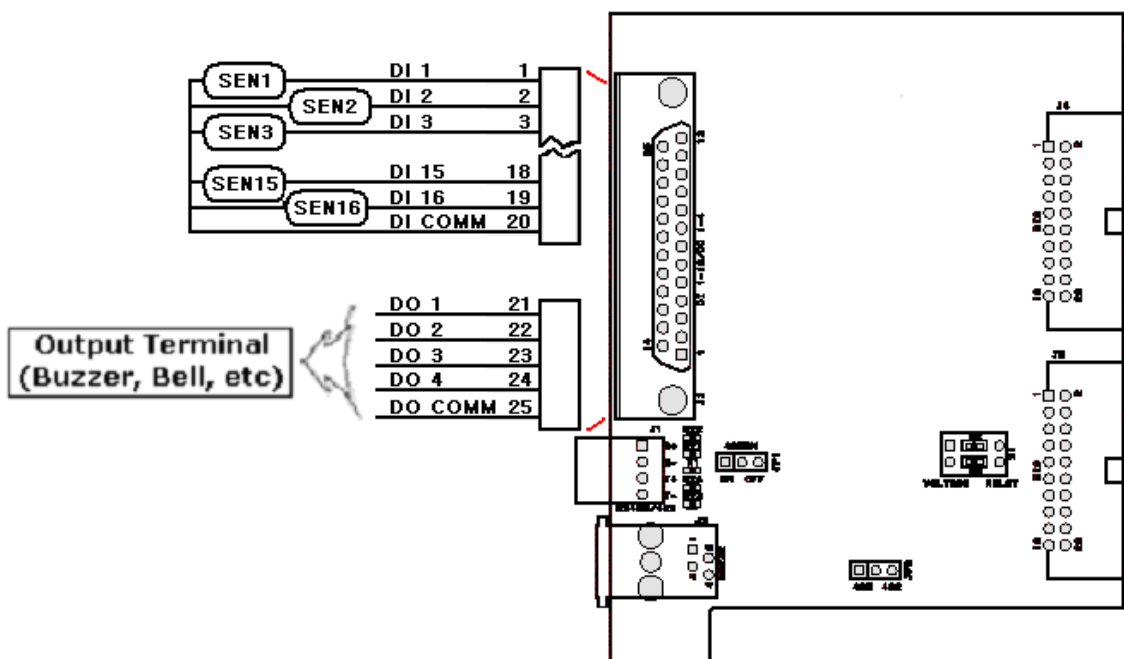

4.4 Reference

4.4.1 Terminal Register

- About Terminal Register

Terminal register was designed to transfer long-distance data through RS-422 or RS-485 safe from possible obstacle and is used for impedance matching of cable. It is not normally for short-distance data transfer (less than 1.2Km) but for long-distance data transfer in case of any possible communication condition. ConExt1604 Card was designed for users to use terminal register simply with a jumper.

- How to Connect Terminal Register

■ RS-422

RS-422 communicates through R+, R-, T+ and T- lines. ConExt1604 Card has 120Ω terminal register between R+ and R- for RS-422 communication. Terminal register between T+ and T- is rarely used, but some extension cards may have the terminal register of T+ and T-. See the below picture for terminal register of ConExt1604 Card.

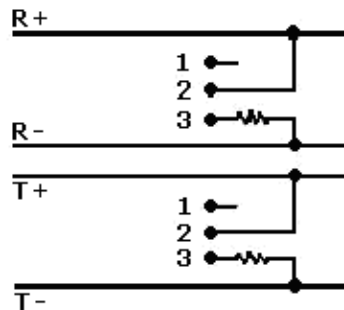

For RS422 communication, connect 1-2 pin of JP1 of ConExt1604 with a jumper to connect the terminal register between R+ and R-. To disconnect the terminal register, connect 2-3 pin of JP1.

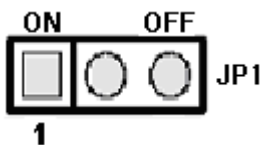

JUMPER	TYPE
1-2(ON)	120Ω MATCHING
2-3(OFF)	NO 120Ω MATCHING

■ **RS-485**

RS-485 communicates through R+ and R-. Therefore, RS-485 communication needs only a terminal register. For RS485 communication, connect 1-2 pin of JP1 of ConExt1604 with a jumper to connect the terminal register between R+ and R-. To disconnect the terminal register, connect 2-3 pin of JP1.



JUMPER	TYPE
1-2(ON)	120Ω MATCHING
2-3(OFF)	NO 120Ω MATCHING

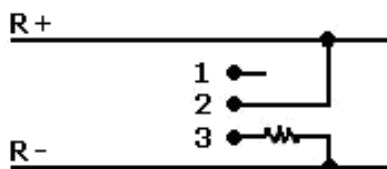

4.4.2 RS485/422 Connector Function

ConExt1604 Card supports RS485 or RS422 communication with J1 Connector. RS485/RS422 communication is selected by a jumper.

- RS485/422 SELECT JUMPER (JP2)

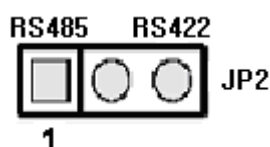

JUMPER	TYPE
1-2	RS485
2-3	RS422

- RS485/422 SELECT

■ **To select RS485 :**

Connect pin 1-2 of JP2 with a jumper. (See the above picture).

■ **To select RS422 :**

Connect pin 2-3 of JP2 with a jumper. (See the above picture).

5. ConExt0404 Card

5.1 DI/DO Connector Function

5.1.1 Digital Input(DI) : for sensor input

- Number of channel : 4
- Type : Relay Type, Voltage Type

▶ Input Requirement(ON)

Voltage Type : Min : 3V, Typ : 5V, Max : 12V

Relay Type : Min : 0Ω, Max :170Ω

- ▶ Sensor input value changes according to DI Type(Voltage / Relay) & External Sensor Type (Normal Open / Normal Close). Please check the value of 0(L)/1(H) after S/W(Application) setting.

ex) For Relay Type & Normal Open Sensor, it shows on SW

Normal => 0(L), Sensor working => 1 (H)

For Relay Type & Normal Close Sensor, it shows on SW

Normal => 1(H), Sensor working => 0(L)

DI Type	External Sensor Type	Sensor	Display on S/W
Voltage Type	Normal Open	Default	1(H)
		Working	0(L)
	Normal Close	Default	0(L)
		Working	1(H)
Relay Type	Normal Open	Default	0(L)
		Working	1(H)
	Normal Close	Default	1(H)
		Working	0(L)

- Please refer to the below for details.

5.1.2 Function Description

■ **DI Circuit**



그림 1 DI Select Switch

■ **DI Select Switch(S1)**

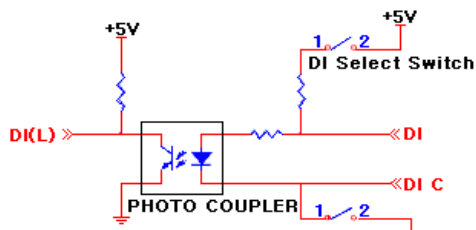

SWITCH	TYPE
ON	Relay Type
OFF	Voltage Type

■ **Relay Type**

- ▶ When the connection interface is on, "DI" is connected to "DI C." (See the Picture 1)
- ▶ Type : magnetic switch, button, relay

■ **Voltage Type**

- ▶ The power flows into DI port to make PHOTO COUPLER work. When it is on, the power inflows to DI port. (See the Picture 1)
- ▶ Type : PNP open collector output sensor

5.1.3 Function Description for Sensor Devices

■ **Normal Open / Normal Close**

▶ **Relay Type**

Normal Open	Normal: disconnected, Working: connected
Normal Close	Normal: connected, Working: disconnected

▶ **Voltage Type**

Normal Open	Normal: 0V, Working: 5V
Normal Close	Normal: 5V, Working: 0V

■ **When devices connected to Sensor are Normal Open,**

▶ **Relay Type**

Relay Sensor	DI Value on S/W
Default	L (0)
Working	H (1)

▶ **Voltage Type**

Voltage Sensor	DI Value on S/W
Default	H (1)
Working	L (0)

■ **When devices connected to Sensor are Normal Close,**

▶ **Relay Type**

Relay Sensor	DI Value on S/W
Default	H (1)
Working	L (0)

▶ **Voltage Type**

Voltage Sensor	DI Value on S/W
Default	L (0)
Working	H (1)

5.1.4 Digital Output(DO) : for relay out

- Number of channel : 4
- Output Type : relay
- Absolute Max. Ratings of Relay : 125V, 0.5A, 30W
- Relay Type: set as Normal Open
- Default: set as OFF on S/W

5.2 Hardware Component

5.2.1 ConExt0404 Card Picture

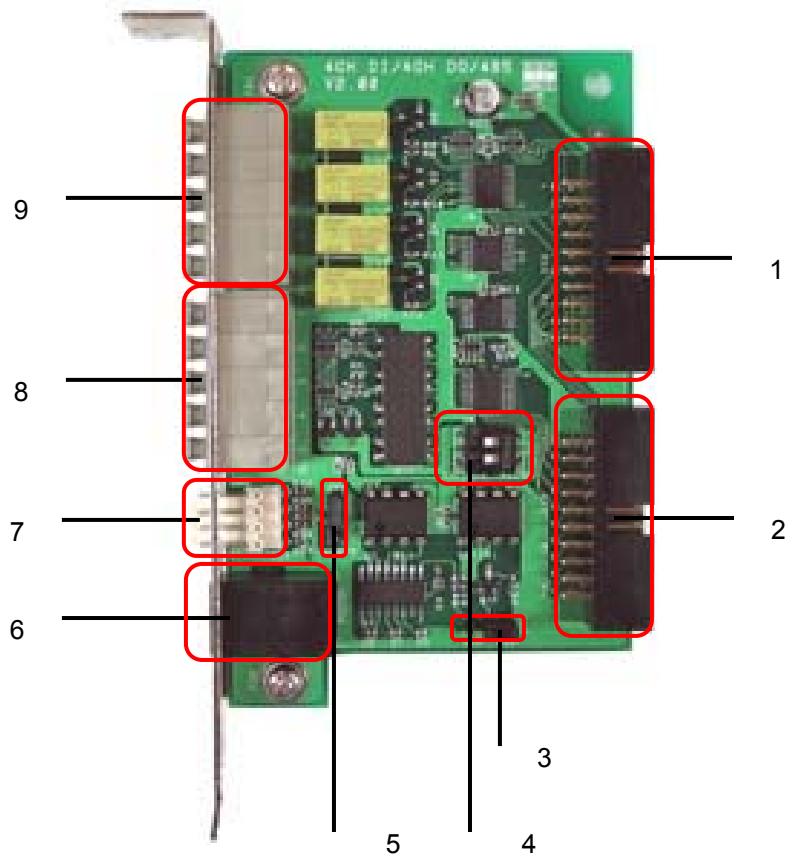

1. DIO (J3) : 20Pin Box Connector
2. DIO (J6) : 20Pin Box Connector
3. JP3 : RS485/422 Select Jumper
4. S1 : DI Type Setting Switch
5. JP1 : Terminal Register Select Jumper
6. J2 : Connector for RS232 signal cable
7. J1 : 4Pin Connector for RS485/422 Device
8. J4 : Terminal Block for Digital Signal Input
9. J5 : Terminal Block for Digital Signal Output

5.2.2 ConExt0404 Card Component Description

1 DIO 20Pin Box Connector (J3)

This connector is used for DI 1-4 and DO 1-4 and connected to capture card.

2 DIO 20Pin Box Connector (J6)

This is the same connector as J3 and used to connect to another extension card.

3 RS485/422 Select Jumper(JP3)

This is a jumper to select RS485/422 function.

4 DI Select Switch(S1)

This is a switch to select DI type. Set Switch1 and 2 to ON or OFF to select Relay Type or Voltage Type.

5 Terminal Register Select Jumper(JP1)

This is a jumper to select 120 Ω terminal register connection.
Refer to 5.4.1 Terminal Register.

6 Connector for RS232 Signal Cable(J2)

This is a connector to connect RS232 cable from external device.

7 4Pin Connector for RS485/422 Device(J1)

This connector is used to connect RS485/422 cable of external device.

6 DI 1-4 Terminal Block(J4)

This is a connector to input DI signals from external. From the above, CH1, CH2, CH3 and CH4 are ports to input DI signals and the bottom is a common port. When the common pin is connected to a channel port by sensor or switch, it is possible to see the sensor or the switch ON/OFF on S/W.

7 DO 1-4 Terminal Block(J5)

This is a connector to output DO signals to external. From the above, CH1, CH2, CH3 and CH4 are ports to output DO signals and the bottom is a common port. DO signals are controlled by S/W. When DO is turned ON, the

channel port which was operated by the relay switch of capture card is connected to common port.

5.3 ConExt0404 Card Connection

5.3.1 How to Connect to Capture Card

Connect to capture card with DIO 20Pin Connector(J4, J5). Refer the Capture Card Manual for details.

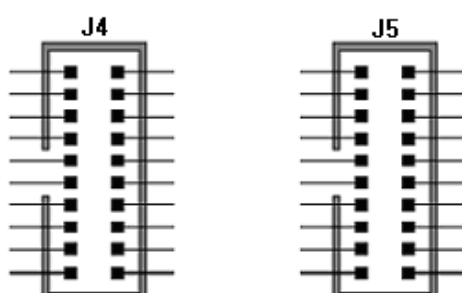

5.3.2 RS485/422 Device Connection

RS485/422 device is used for Pan/Tilt/Zoom camera control. Connect RS485/422 device to J1 with 4Pin Connector.

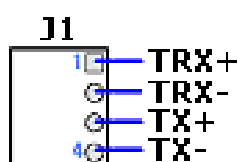

5.3.3 Connection for RS485/422 Device Signal Cable

This is connected to COM PORT of other system by RJ connector. See the below picture for the pin arrangement.

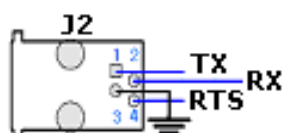

□ Refer to Capture Card Manual to connect ConExt0404 Card to Capture Card.

5.3.4 DI/DO Connection

DI is connected to external sensor or switch by J4 connector while DO to external buzzer or bell etc. by J5 connector. See the below picture for details.

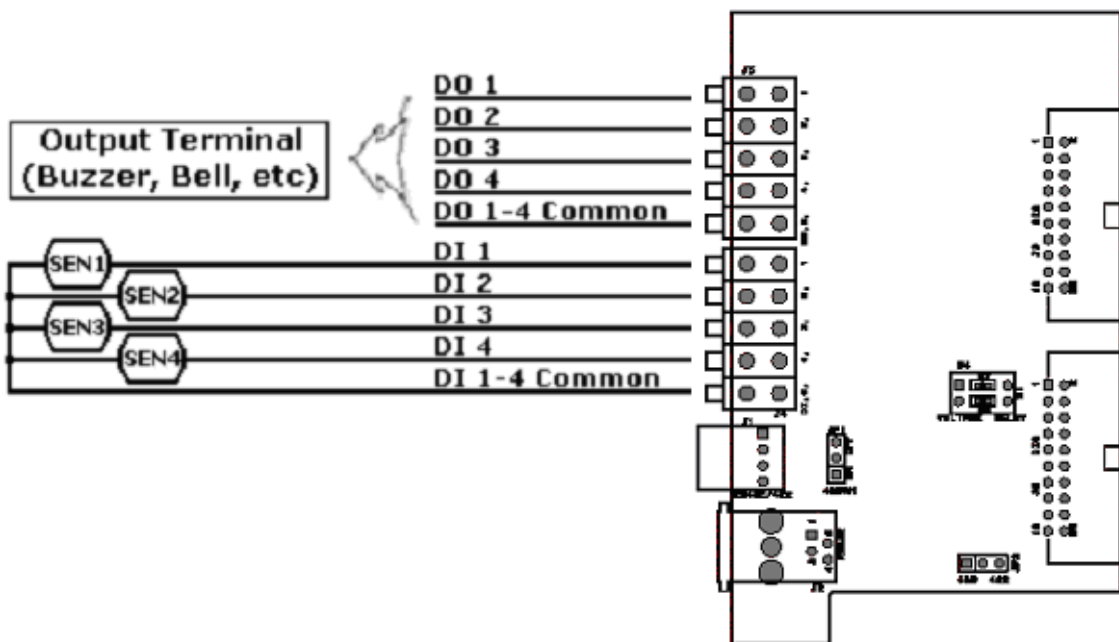

5.4 Reference

5.4.1 Terminal Register

- About Terminal Register

Terminal register was designed to keep long-distance data through RS-422 or RS-485 safe from possible obstacle and is used for impedance matching of cable. It is not normally for short-distance data transfer (less than 1.2Km) but for long-distance data transfer in case of any possible communication condition. ConExt0404 Card was designed for users to use terminal register simply with a jumper.

- How to Connect Terminal Register

■ RS-422

RS-422 communicates through R+, R-, T+ and T- lines. ConExt0404 Card has 120Ω terminal register between R+ and R- for RS-422 communication. Terminal register between T+ and T- is rarely used, but some extension cards may have

the terminal register. See the below picture for terminal register of ConExt0404 Card.

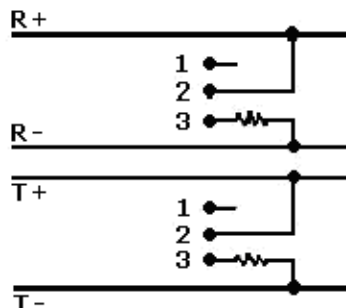

For RS422 communication, connect 1-2 pin of JP1 of ConExt0404 with a jumper to connect the terminal register between R+ and R-. To disconnect the terminal register, connect 2-3 pin of JP1.



JUMPER	TYPE
1-2(ON)	120Ω MATCHING
2-3(OFF)	NO 120Ω MATCHING

■ **RS-485**

RS-485 communicates through R+ and R-. Therefore, RS-485 communication needs only a terminal register. For RS485 communication, connect 1-2 pin of JP1 of ConExt0404 with a jumper to connect the terminal register between R+ and R-. To disconnect the terminal register, connect 2-3 pin of JP1.

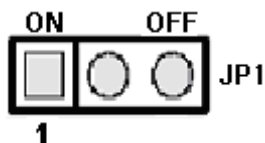

JUMPER	TYPE
1-2(ON)	120Ω MATCHING
2-3(OFF)	NO 120Ω MATCHING

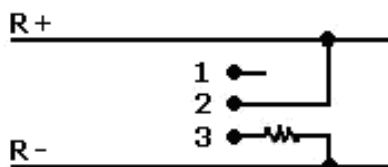

4.4.2 RS485/422 Connector Function

ConExt0404 Card supports RS485 or RS422 communication with J1 Connector.
RS485/RS422 communication is selected by a jumper.

- RS485/422 SELECT JUMPER (JP3)

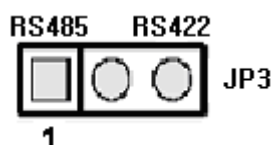

JUMPER	TYPE
1-2	RS485
2-3	RS422

- RS485/422 SELECT

- **To select RS485 :**

Connect pin 1-2 of JP3 with a jumper. (See the above picture).

- **To select RS422 :**

Connect pin 2-3 of JP3 with a jumper. (See the above picture).