

Indoor/Outdoor Pendant Mount Bracket



ACCESSORIES

MNT-PEND-WALL Pendant wall bracket for dome cameras

Weight: 0.7 kg (1.5 lbs)

- Male 1-1/2" NPT camera connection
- Female 3/4" NPT conduit entry
- Creates outdoor seal with compatible dome cameras that meets IP66 standards

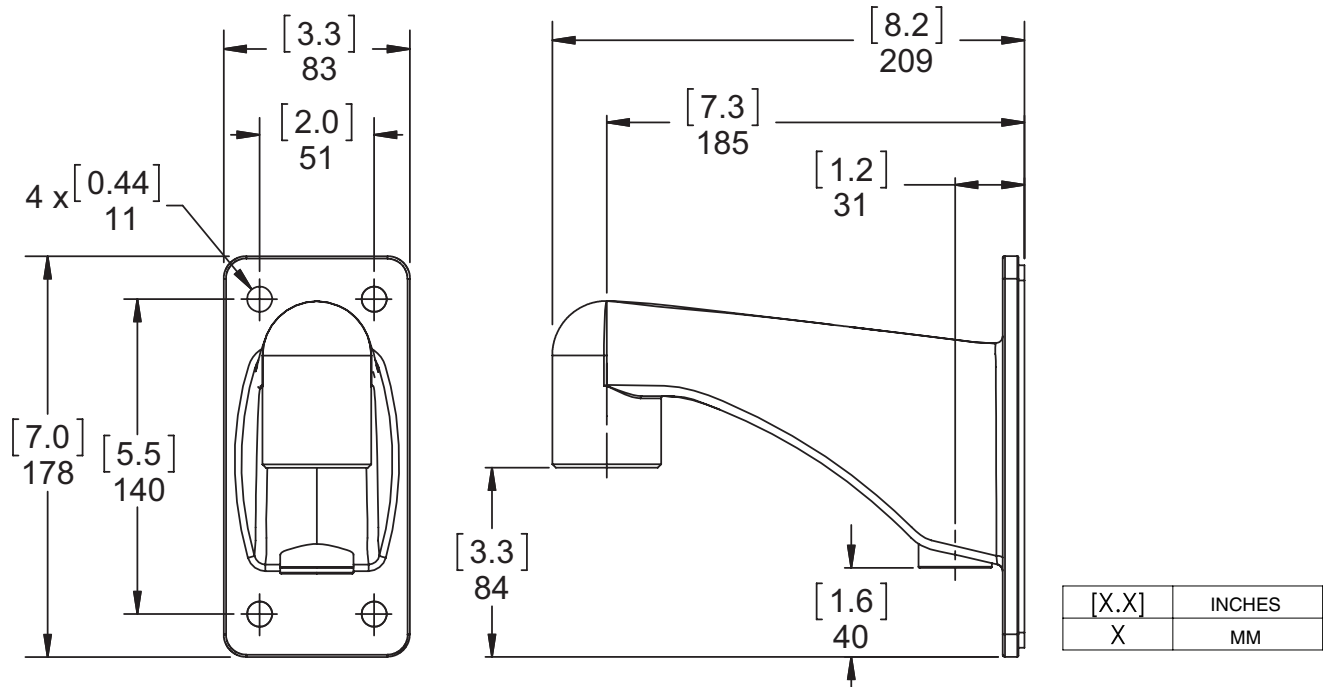

SUPPORT 1.888.281.5182 | sales@avigilon.com | avigilon.com

