

MotionProtect Plus Fibra User Manual

Updated March 11, 2022



MotionProtect Plus Fibra — a wired motion detector with an additional microwave sensor. It can recognize movement at a distance of up to 12 meters. Together with the IR sensor, it applies a radio-frequency scan that filters out thermal interference.

It does not react to animals up to 50 centimeters tall and weighing up to 20 kilograms when properly installed and configured. It is intended for indoor installation.



The detector is compatible with [Hub Hybrid \(2G\)](#) and [Hub Hybrid \(4G\)](#). Connection to other [hubs](#), [radio signal range extenders](#), [ocBridge Plus](#), and [uartBridge](#) is not supported. Integration with other security systems is not provided

MotionProtect Plus Fibra only works as a part of the Ajax security system, communicating with the hub via the secure Fibra protocol. The wired connection range is up to 2000 meters when connected via the twisted pair U/UTP cat.5.

MotionProtect Plus Fibra is the device of the new Fibra wired product line. Such devices can only be purchased, installed and administered by accredited Ajax partners.

Buy MotionProtect Plus Fibra

Functional elements

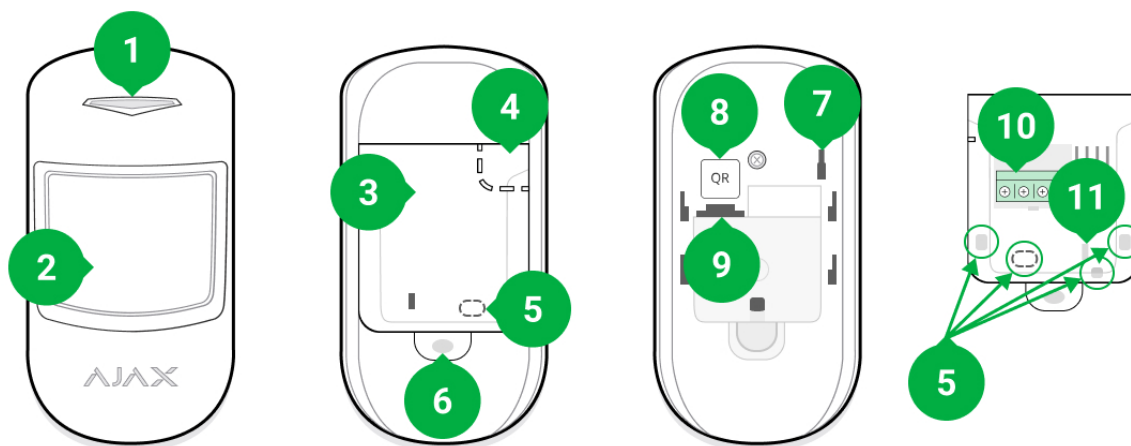

1. LED indicator.
2. Motion detector lens.
3. SmartBracket mounting plate (to remove the plate, slide it down).
4. Perforated part of the mounting plate. Intended to trigger a tamper in case of any attempt to detach the detector from the surface. Do not break it off.
5. Perforated part for wire output.
6. The hole for attaching the SmartBracket mounting panel with a screw.
7. Tamper button. Triggers when an attempt is made to detach the detector from the surface or remove the mounting panel.
8. QR code. Used to connect the detector to the Ajax security system.
9. Terminal block connection socket.
10. Terminal block for detector connection.
11. A hole for fixing the wires with ties.

Operating principle

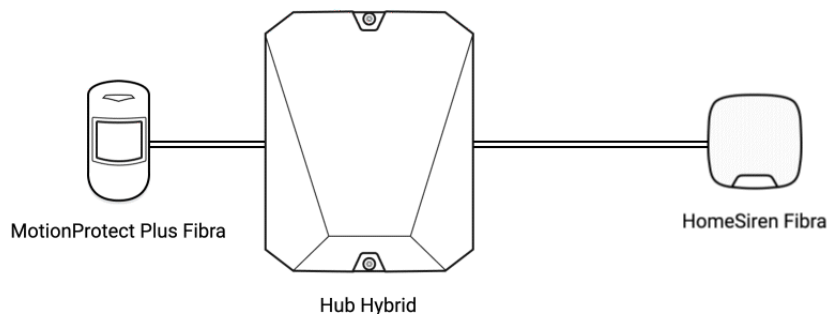

MotionProtect Plus Fibra is a wired motion detector with an additional microwave sensor. Using the IR sensor, it can identify intrusions by detecting moving objects with temperatures close to that of the human body.

When MotionProtect Plus Fibra detects motion, it conducts an additional RF scan of the room to eliminate false alarms due to thermal interference: air flows, heated curtains and blinds, fans, fireplaces, air conditioners, and other likely sources of false alarms.

When an armed detector identifies motion, it instantly sends an alarm to the hub, which activates the sirens connected to the system, triggers scenarios, and notifies users and the security company. All MotionProtect Plus Fibra alerts and events are recorded in the notification feed of the Ajax app.

Users know exactly where motion is detected. The notifications contain the name of the hub (name of the guarded object), the name of the device, and the virtual room to which the detector is assigned.

How Ajax notifies users of alerts

More about Ajax motion detectors



The detector doesn't go into armed mode instantly. The time it takes to switch to armed mode depends on two factors: exit delays (specified in the detector settings) and the hub – detector ping interval (Fibra settings, the default value is 36 seconds). In the first case, the delay is set by a user or a PRO with administrator rights. In the second case, the delay occurs because it takes one ping interval for the hub to notify the detector about the transition to armed mode.

Fibra data transfer protocol

The detector uses Fibra technology to transmit alarms and events. This is a two-way wired data transfer protocol that provides fast and reliable communication between the hub and the rest of the devices. Using the bus connection method, Fibra delivers alarms and events instantly, even if 100 detectors are connected to the system.

Fibra supports floating key block encryption and verifies each communication session with devices to prevent sabotage and forgery. The protocol requires regular polling of detectors by the hub with a predetermined frequency to monitor communication and display the status of the system devices in real time in the Ajax apps.

[More about Fibra protocol \(in progress\)](#)

Pet immunity

When properly installed and configured, MotionProtect Plus Fibra does not react to animals up to 50 centimeters tall and weighing up to 20 kilograms.

The detector must be installed at a height of 2.4 meters without any obstruction to its view – for example, in a corner where the view will not be blocked by a closet or other furniture on which a pet can climb.

It is also important to set the proper sensitivity in the [detector settings](#):

- High – the detector does not respond to cats (up to 25 cm tall).
- Medium – it does not respond to small dogs (up to 35 cm tall).
- Low – it does not respond to animals up to 50 cm tall.

When indoor motion detectors are installed below the recommended height, animals move in the hypersensitive zone. If a shepherd walks on its hind legs or even a small spaniel plays on a chair, the detector can raise an alarm. The detector will also raise an alarm if the animal is able to jump to the level of the detector or move near it.

[Why detectors react to animals and how to avoid this](#)

Temperature compensation

The detector perceives people and other objects as heat spots. The device monitors these heat spots and, if they move, detects an alarm. MotionProtect Plus Fibra reacts to the movement of heat spots whose temperature is close to the human body.

When the ambient temperature is about the temperature of the human body, the correct operation of the detector is not guaranteed unless temperature compensation is applied. It is used in all Ajax motion detectors. With temperature compensation, the detector recognizes motion across the entire operating temperature range.

[Learn more](#)

Sending events to the monitoring station

The Ajax security system can transmit alarms to the [Ajax PRO Desktop](#) monitoring app as well as the central monitoring station (CMS) in the formats of the **Sur-Gard protocol (Contact ID)**, **SIA (DC-09)**, and other proprietary protocols. A complete list of supported protocols is [available here](#).

[Which CMSs can the Ajax security system be connected to](#)

MotionProtect Plus Fibra can transmit the following events:

1. Motion alarm.
2. Tamper alarm / recovery.
3. Loss / restoration of connection to the hub.
4. Temporary deactivation / activation of the detector.
5. Unsuccessful attempt to arm the security system (with [Integrity Check](#) enabled).

When an alarm is received, the operator of the security company monitoring station knows exactly what happened and precisely where to send a fast response team on the site. Addressability of each Ajax device allows you to send not only events to the PRO Desktop or to the CMS but also the type of the device, the name of the device, and the virtual room to which the detector is assigned. Note that the list of transmitted parameters may differ depending on the type of CMS and the selected protocol for communication with the monitoring station.



The device ID, the loop (zone) number, and the bus number can be found in its [states in the Ajax app](#).

Detector placement

When choosing where to place the detector, consider the parameters that affect its normal operation: Fibra signal level, length of the cable for connecting the detector, and the motion detection zone.

Consider the placement recommendations when designing your facility's security system. Design and installation of the security system should be carried out by professionals. A list of authorized official Ajax partners is [available here](#).

Design and preparation

For the system to work correctly, it is important to properly design the project and install all devices correctly. Failure to follow the basic installation rules and recommendations of this manual may result in detector malfunction, false alarms, or loss of connection with already installed devices.

When designing the layout scheme of the detectors, consider the wiring diagram of the power cables laid on the site. Signal cables must be laid at a distance of at least 50 cm from the power cables when lying parallel, and, if they intersect, it must be at a 90° angle. Note that, if you connect multiple devices on the same bus, detectors are connected in sequence.

The maximum number of connectable devices for the Hub Hybrid is 100 at the default



settings.

How to calculate the number of connectable detectors (in progress)

For facilities that are under construction or renovation, cables are laid after the main wiring of the facility. Use special protective tubes to route system cables to organize and secure the wires; special ties, clips, and staples can be used to secure them.

When laying wires externally (without mounting them inside the walls), use an electric channel raceway. Raceways should be no more than half-filled with cables. Do not allow cables and wires to sag. The raceway should be hidden from view if possible – for example, behind furniture.





We recommend laying cables inside walls, floors, and ceilings. This will provide greater security: the wires will not be visible, and it will be impossible for an intruder to access them.

When selecting a cable, consider the length of the connection lines and the number of detectors to be connected; these parameters affect the signal strength. We recommend using shielded copper cables with a high-quality insulation layer.

When installing, observe the bend radius that the manufacturer specifies in the cable specs. Otherwise, you risk damaging or breaking the conductor.

Be sure to check all cables for bends and physical damage before installation. Perform the installation in a way that minimizes the possibility of damage to the cables from the outside.

Signal strength and wire length

The Fibra signal level is determined by the number of undelivered or corrupted data packages over a certain period. The icon  on the **Devices**  tab indicates the signal strength:

- Three bars – excellent signal strength.

- Two bars – good signal strength.
- One bar – low signal strength, stable operation is not guaranteed.
- Crossed out icon – no signal.

The signal strength is influenced by the following factors: the number of devices connected to one bus, the length and type of cable, and the proper connection of the wires to terminals.



Check the Fibra signal strength before final installation of the detector. With a signal strength of one or zero bars, we do not guarantee stable operation of the device.

The maximum permissible cable length depends on its type, its material, and the method of connecting the devices. When connected using the **Star connection method** with a twisted pair U/UTP cat.5 (4×2×0.51), the wired connection length can be up to 2,000 meters.

When devices are connected using the **Ring connection method**, the maximum cable length is 500 meters when using a twisted pair.

How to calculate the wire connection length (in progress)



Connecting devices using the **Ring connection method** will be available with future OS Malevich updates. Hardware update of Hub Hybrid won't be required.

[How OS Malevich updates](#)

Detection zone

When choosing where to place the detector, perform the [Detection zone test](#) to check the operation of the device and accurately determine the sector in which the detector registers motion.

The location of the detector determines the area to be monitored and the effectiveness of the security system. When choosing the installation location,

consider the direction of the detector lens, its viewing angles, and the presence of obstacles to the view of the lens.

The direction of the detector lens should be perpendicular to the intended path of entry into the room.

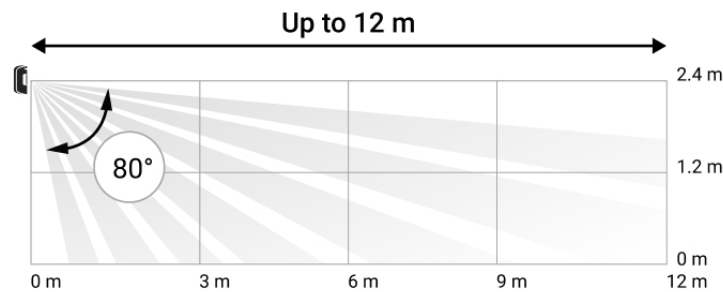

Horizontal detector viewing angle

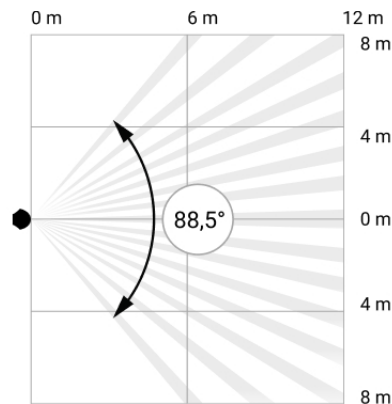

Vertical detector viewing angle

Do not install the detector

1. Outdoors – This can lead to false alarms and detector failure.
2. In places where objects and structures can block the view of the detector – For example, behind a flower or a column.
3. In places where glass structures may block the detector's view; it doesn't register movement behind glass.
4. Inside premises with temperature and humidity outside the permissible limits – This could damage the detector.

Installation and connection



Before installing MotionProtect Plus Fibra, make sure that you have selected the optimal location and that it meets the conditions of this manual. Wires must be hidden from view and located in a place that is difficult for intruders to access to reduce the likelihood of sabotage.

Ideally, the wires should be embedded in the walls, floor, or ceiling. Before the final installation, conduct tests of the detection zone and the Fibra signal strength.

When connecting, do not twist the wires together; solder them. The ends of the wires that will be inserted into the detector's terminals should be tinned or crimped with a special sleeve. This will ensure a reliable connection. Follow safety procedures and regulations for electrical installation work.

In order to mount a detector:

1. Disconnect the external power and the hub's backup battery.

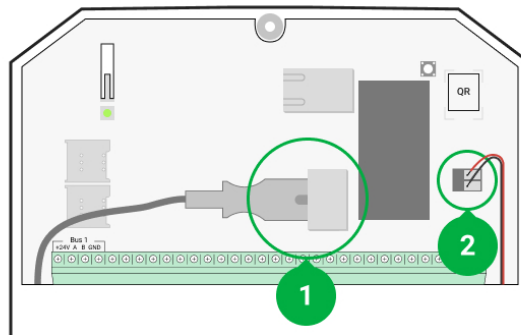

- 1 – External power supply
- 2 – Backup battery

2. Plug the cable into the hub and connect the wires to the bus terminals.

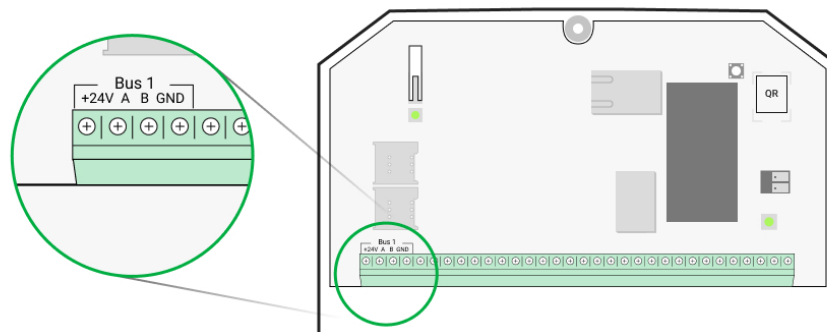

+24V – power supply input
A, B – signal terminals
GND – ground

3. Remove the SmartBracket mounting panel from the detector and carefully break out the perforated part to lead the cable out. If you want to lead the wire out from the bottom or the side of the detector, drill a suitable hole in the SmartBracket panel.

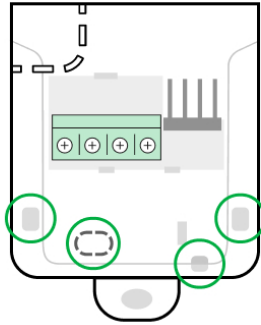

4. Run the cable from the hub into the detector's body through the hole made.
5. Connect the cable to the terminals according to the scheme below. Follow the polarity and connection order of the wires. Securely fasten the wires to the terminals. Secure the cable with ties.

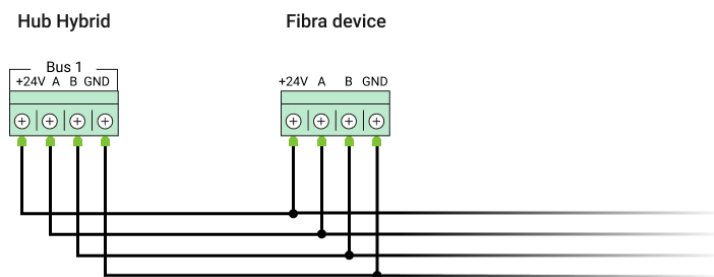

+24V – power supply input
A, B – signal terminals
GND – ground

6. If the detector is not the last in the connection line, prepare and wire the cable for the next detector to the MotionProtect Plus Fibra terminals in advance.

7. If the detector is the last in the line, install a termination resistor at the end of the connecting line in case the **Star connection method** is in place. With the **Ring connection method**, a termination resistor is not required.

More about connection methods (in progress)



We recommend connecting devices via the **Ring connection method** (hub – detector – hub), because, if the line is broken, the devices will be connected via the **Star connection method** and will continue to transmit events to the hub. Notification about the **Ring** failure will be sent to users and the security company.



8. Temporarily install the SmartBracket mounting panel to a vertical surface or corner using double-sided tape or other temporary fasteners at the chosen installation place. This is needed to test the detector. The installation height is 2.4 meters.
9. Turn on the hub and supply the connected detector with power. When power is applied, an LED will notify that the detector is turned on.
10. Add a MotionProtect Plus Fibra to the system.
11. Conduct the signal strength test. The recommended signal strength value is two or three bars. Otherwise, check the connection and the condition of the wire.
12. Run a detection zone test. In order to check the motion detector, walk around the premises while observing the LED and determine the detection zone of the detector. The maximum range of motion detection by the detector is 12 meters. If the detector did not respond to motion during the test in 5 out of 5 cases, it should be installed in a different location.
13. Attach the SmartBracket mounting panel with at least two fixation points using bundled screws. Use one of them on the perforated part of the mount

above the tamper. When using other fasteners, make sure they do not damage or deform the mounting panel.



Double-sided tape can only be used for temporary installation. The device attached by the tape may come unstuck from the surface at any time. As long as the device is taped, the tamper will not be triggered when the detector is detached from the surface.

14. Put the detector on the SmartBracket and secure it with a screw.

Adding to the system



The detector is only compatible with Hub Hybrid (2G) and Hub Hybrid (4G). Adding and configuring Fibra devices is only possible through the Ajax PRO app by a user with administrator rights.

[Types of accounts and their rights](#)

Before adding a device

1. Install the [PRO version of the app](#). Log in to a PRO [account](#) or create new one if you don't have it yet. Add a detector-compatible hub to the app, set the necessary settings, and create at least one [virtual room](#).
2. Make sure that the hub is turned on and has Internet access via Ethernet and/or mobile network. You can check the connection in the Ajax app or by looking at the LED on the hub board: it should light up white or green.
3. Make sure the hub is disarmed and does not start updates by checking its status in the Ajax app.
4. Make sure the detector is physically connected to the hub.

How to add MotionProtect Plus Fibra

There are two ways to add devices: manually and automatically.

To add a detector manually:

1. Open the PRO version of the app. Select the hub you want to add MotionProtect Plus Fibra to.
2. Go to the **Devices** tab  and click **Add device**.
3. Name the detector, scan or type in the QR code (placed on the detector body and the packaging), select a room and a group (if the group mode is enabled).
4. Click **Add**.

To have the detector added automatically:

1. Open the PRO version of the app. Select the hub you want to add MotionProtect Plus Fibra to.
2. Go to the **Devices** tab  and click **Add device**.
3. Select **Add Bus Devices**. The hub will scan all buses. After scanning, a list of all devices physically connected to the hub that have not yet been added to the system will appear on the screen. The detectors are sorted by the buses they are physically connected to.

After scanning the buses, the detectors will be displayed in the **Devices**  tab. The order of the devices will depend on which bus they are connected to.

By default, the device name includes the detector name and its identifier. To connect detectors to a hub, edit their name, and assign a room and a group to the device (if the group mode is activated in the hub settings).

To check which specific detector you want to add, we have provided two methods: LED indication and detector triggering.

Method 1: Via LED indication.

In the list of available devices to add, click on any option. The LED of this detector will start blinking after you press it. This way, you'll know exactly which detector you're adding, how to name it, and which room and group it should be assigned to.

To add a detector:

1. Click on the device in the list.
2. Create a name.
3. Specify the room and the security group (if enabled).
4. Click **Save**.

If the detector is connected to the hub successfully, it will disappear from the list of available detectors.

Method 2: By detector alarm.

Enable the **Add Detectors by Alarm** option above the list of detectors.

Trigger an alarm by walking past the motion detector. When triggered, the detector will move to the top of the list to the **Recently triggered devices** category. The detector will stay in this category for 5 seconds, after which it will be moved back to the bus category.

To add a detector:

1. Click on the device in the list.
2. Create a name.
3. Specify the room and the security group (if enabled).
4. Click **Save**.

If the detector is connected to the hub successfully, it will disappear from the list of available detectors.



Device status updates depend on the Fibra settings; the default value is 36 seconds.

If the connection fails, check the accuracy of the wired connection and try again. If hub already has the maximum number of devices added (for Hub Hybrid, the default is 100), you will get an error notification when you add one.

MotionProtect Plus Fibra only works with one hub. When connected to a new hub, the detector stops exchanging commands with the old one. Once added to a new hub, MotionProtect Plus Fibra is not removed from the list of devices of the old hub. This must be done through the Ajax app.

Malfunctions

When a detector identifies a malfunction (for example, there is no connection via the Fibra protocol), the Ajax app displays a malfunction counter in the upper left corner of the device icon.





All faults can be seen in the detector states. Fields with malfunctions will be highlighted in red.





Malfunction is displayed if:

- The detector temperature is out of acceptable limits.
- The detector body is open (tamper is triggered).
- There is no connection with the hub via the Fibra protocol.

Icons

The icons display some of MotionProtect Plus Fibra states. You can view them in the Ajax app on the **Devices** tab .

Icon	Meaning
	Fibra signal strength, displays the signal strength between the hub and the detector. The recommended value is 2–3 bars. Learn more (in progress)
	The detector operates in the Always Active mode. Learn more
 	Entry and/or exit delay is enabled. Learn more

	<p>MotionProtect Plus Fibra will work when the Night Mode is enabled.</p> <p><u>Learn more</u></p>
	<p>MotionProtect Plus Fibra has detected motion. The detector identifies motion only in the armed mode.</p>
	<p>MotionProtect Plus Fibra is temporarily deactivated by a user or PRO with administrator rights.</p> <p><u>Learn more</u></p>
	<p>MotionProtect Plus Fibra has been disabled due to exceeding the number of alarms.</p> <p><u>Learn more</u></p>
	<p>MotionProtect Plus Fibra has tamper triggering events temporarily deactivated by a user or PRO with administrator rights.</p> <p><u>Learn more</u></p>

States

The states include information about the device and its operating parameters. MotionProtect Plus Fibra states can be found in the Ajax app:

1. Go to the **Devices** tab .
2. Choose MotionProtect Plus Fibra from the list.

Parameter	Meaning
Malfunction	<p>Clicking on  opens a list of malfunctions of MotionProtect Plus Fibra.</p> <p>The field is displayed if a malfunction is detected.</p>
Temperature	<p>Detector temperature – it is measured on the processor and changes gradually.</p>



	<p>Acceptable measurement error between the value in the app and the room temperature: 2–4°C.</p> <p>The value is updated as soon as the detector identifies a temperature change of at least 1°C.</p>
Fibra signal strength	<p>Signal strength between the hub and MotionProtect Plus Fibra. Recommended values – 2–3 bars.</p> <p>Fibra – protocol for transmitting MotionProtect Plus Fibra events and alarms</p> <p>Learn more (in progress)</p>
Connection via Fibra	<p>Status of the connection between the hub and the detector:</p> <ul style="list-style-type: none"> • Online – the detector is connected to the hub. • Offline – the detector is not connected to the hub. Check the detector connection to the bus.
Bus voltage	<p>Bus voltage value.</p> <p>TBC</p>
Lid	<p>The status of the tamper that responds to demount or opening of the body:</p> <ul style="list-style-type: none"> • Open – the detector is removed from its SmartBracket mounting plate. • Closed – the detector is mounted. <p>Learn more</p>
Delay When Entering, sec	<p>Delay time when entering (5 to 120 seconds).</p> <p>Delay when entering (alarm activation delay) is the time the user has to disarm the security system after entering the secured area.</p> <p>Learn more</p>

Delay When Leaving, sec	<p>Delay time when leaving (5 to 120 seconds).</p> <p>Delay when leaving (arming delay) is the time the user has to leave the secured area after arming.</p> <p><u>Learn more</u></p>
Delay when entering for the Night mode, sec	<p>Delay time when entering in the Night mode.</p> <p>Delay when entering (alarm activation delay) is the time the user has to disarm the security system after entering the premises.</p> <p><u>Learn more</u></p>
Delay when leaving for the Night mode, sec	<p>Delay time when leaving in the Night mode.</p> <p>Delay when leaving (arming delay) is the time the user has to leave the premises after arming.</p> <p><u>Learn more</u></p>
Sensitivity	<p>Sensitivity level of the motion detector:</p> <ul style="list-style-type: none"> • Low – it does not respond to animals up to 50 cm tall. • Medium (by default) – it does not respond to small dogs (up to 35 cm tall). • High – the detector does not respond to cats (up to 25 cm tall).
Always Active	<p>If active, the detector is always in armed mode and detects motion.</p> <p><u>Learn more</u></p>
Temporary Deactivation	<p>Shows the status of the device temporary deactivation function:</p> <ul style="list-style-type: none"> • No – the device operates normally and transmits all events. • Lid only – the hub administrator has disabled notifications about triggering on

	<p>the device tamper.</p> <ul style="list-style-type: none"> • Entirely – the hub administrator has excluded the detector from the system. The device does not execute system commands and does not report alarms or other events. • By number of alarms – the device is automatically disabled when the number of alarms is exceeded (specified in the <u>Devices Auto Deactivation</u> settings). <p><u>Learn more</u></p>
Firmware	Detector firmware version.
ID	Detector identifier / serial number – located on the packaging box and on the body under the SmartBracket mounting panel.
Device №	Number of the detector loop (zone).
Bus №	The number of the hub bus the detector is physically connected to.

Settings

To change the detector settings in the Ajax app:

1. Go to the **Devices** tab .
2. Choose MotionProtect Plus Fibra from the list.
3. Go to **Settings** by clicking on the gear icon. .
4. Set the required parameters.
5. Click **Back** to save the new settings.

Settings	Meaning
First field	<p>Detector name. Displayed in the list of hub devices, SMS text, and notifications in the event feed.</p> <p>To change the detector name, click on the pencil icon .</p>

	The name can contain up to 12 Cyrillic characters or up to 24 Latin characters.
Room	<p>Selecting the virtual room to which MotionProtect Plus Fibra is assigned.</p> <p>The room name is displayed in the text of SMS and notifications in the event feed.</p>
Delay When Entering, sec	<p>Selecting the delay time when entering.</p> <p>Delay when entering (alarm activation delay) is the time the user has to disarm the security system after entering the premises.</p> <p><u>What Is Delay When Entering</u></p>
Delay When Leaving, sec	<p>Selecting the delay time when leaving.</p> <p>Delay when leaving (arming delay) is the time the user has to leave the premises after arming.</p> <p><u>What Is Delay When Leaving</u></p>
Arm in the Night Mode	<p>If this option is enabled, the detector will go into the arming mode, when the system is set to the Night mode.</p> <p><u>What is the Night mode</u></p>
Delay when entering for the Night mode, sec	<p>Delay time when entering in the Night mode.</p> <p>Delay when entering (alarm activation delay) is the time the user has to disarm the security system after entering the premises.</p> <p><u>What Is Delay When Entering</u></p>
Delay when leaving for the Night mode, sec	<p>Delay time when leaving in the Night mode.</p> <p>Delay when leaving (arming delay) is the time the user has to leave the premises after arming.</p> <p><u>What Is Delay When Leaving</u></p>

Alarm LED indication	When off, the detector's LED will not alert you about an alarm and a tamper triggering.
Sensitivity	<p>Sensitivity level of the motion detector.</p> <p>The choice depends on the type of the object, the presence of probable sources of false alarms, and the type of the protected area:</p> <ul style="list-style-type: none"> • Low – it does not respond to animals up to 50 cm tall. • Medium (by default) – it does not respond to small dogs (up to 35 cm tall). • High – the detector does not respond to cats (up to 25 cm tall). <p><u>Why motion detectors react to animals and how to avoid it</u></p>
Always Active	<p>If active, the detector is always in the armed mode and detects motion.</p> <p><u>Learn more</u></p>
Alert with a siren if motion is detected	<p>If active, <u>sirens</u> added to the system activate when motion is detected by the MotionProtect Plus Fibra detector.</p>
Fibra signal strength test	<p>Switches the detector to the Fibra signal strength test mode.</p> <p>The test allows you to check the signal strength between the hub and the detector over the Fibra wired data transfer protocol to determine the optimal installation location.</p> <p>Learn more (in progress)</p>
Detection Zone Test	<p>Switches the detector to the detection zone test mode.</p> <p>The test enables the user to check the detector's reaction to the movement and determine the optimal installation location.</p> <p><u>Learn more</u></p>

User Manual	Opens MotionProtect Plus Fibra User Manual in the Ajax app.
Temporary Deactivation	<p>Allows to disable the device without removing it from the system.</p> <p>Two options are available:</p> <ul style="list-style-type: none"> • Entirely – the device will not execute commands or participate in automation scenarios. The system will ignore device alarms and other notifications. • Lid only – the system will ignore notifications about the tamper triggering. <p>Learn more</p> <p>The system can also automatically deactivate devices when the set number of alarms is exceeded.</p> <p>Learn more</p>
Unpair Device	Unpairs the detector, disconnects it from the hub, and deletes its settings.

Indication

Indication	Event	Note
When power is connected, it lights up green once.	The detector is on.	
Lights up green for 1 second.	Motion alarm / tamper triggering.	The detector records movement once every 5 seconds.
Smoothly lights up and goes out after an alarm or a tamper triggering.	Low bus voltage.	A voltage of 7 V and below is considered low.

Functionality testing



The Ajax security system provides several types of tests that help you make sure that installation points of devices are selected correctly. MotionProtect

Plus Fibra tests do not start straight away but begin no later than a single hub-detector ping period (36 seconds with a default hub settings of the hub). You can change the ping period of devices in the **Fibra** menu of the hub settings.

There are 2 tests available for MotionProtect Plus Fibra:

- **Fibra signal strength test (in progress)**
- **Detection Zone Test**

To run a test in the Ajax app:

1. Select the hub if you have several of them or if you are using the PRO version of the app.
2. Go to the **Devices**  menu.
3. Select MotionProtect Plus Fibra.
4. Go to **Settings** .
5. Select a test:
 - Fibra Signal Strength Test.
 - Detection zone.
6. Launch and conduct a test.

Maintenance

Check the functioning of the detector on a regular basis. The optimal frequency of checks is once every three months. Clean the detector body from dust, cobwebs, and other contaminants as they emerge. Use a soft dry cloth suitable for equipment care.

Do not use substances that contain alcohol, acetone, gasoline, or other active solvents to clean the detector. Wipe the lens gently as scratches may impair the detector sensitivity.

Technical specifications

[Learn more](#)

[Compliance with standards](#)

Complete set

1. MotionProtect Plus Fibra.
2. SmartBracket mounting panel.
3. Installation kit.
4. Quick Start Guide.

Warranty

Warranty for the AJAX SYSTEMS MANUFACTURING Limited Liability Company products is valid for 2 years after the purchase.

If the device does not function correctly, please contact the Ajax Technical Support first. In most cases, technical issues can be resolved remotely.

[Warranty obligations](#)

[User Agreement](#)

Contact Technical Support:

- [e-mail](#)
- [Telegram](#)

Subscribe to the newsletter about safe life. No spam

Email

Subscribe