

Installation Guide

Avigilon™ H4 PTZ Dome Camera Models:

1.0C-H4PTZ-DC45 and 2.0C-H4PTZ-DC30

Important Safety Information

This manual provides installation and operation information and precautions for the use of this device. Incorrect installation could cause an unexpected fault. Before installing this equipment read this manual carefully. Please provide this manual to the owner of the equipment for future reference.



This Warning symbol indicates the presence of dangerous voltage within and outside the product enclosure that may result in a risk of electric shock, serious injury or death to persons if proper precautions are not followed.



This Caution symbol alerts the user to the presence of hazards that may cause minor or moderate injury to persons, damage to property or damage to the product itself if proper precautions are not followed.



WARNING — Failure to observe the following instructions may result in severe injury or death.

- Installation must be performed by qualified personnel only, and must conform to all local codes.
- This product is intended to be supplied by a UL Listed Power Unit marked “Class 2” or “LPS” or “Limited Power Source” with output rated 24 VAC +/- 10%, 32 VA min.; 24 VDC +/- 10%, 23 W min. or Power over Ethernet (PoE) Plus IEEE802.3at compliant Power Sourcing Equipment (PSE).
- Any external power supply connected to this product may only be connected to another Avigilon product of the same model series. External power connections must be properly insulated.
- Do not connect directly to mains power for any reason.



CAUTION — Failure to observe the following instructions may result in injury to persons or damage to the device.

- Do not install near any heat sources such as radiators, heat registers, stoves, or other sources of heat.
- Do not subject the device cables to excessive stress, heavy loads or pinching.
- Do not open or disassemble the device. There are no user serviceable parts.
- Refer all device servicing to qualified personnel. Servicing may be required when the device has been damaged (such as from a liquid spill or fallen objects), has been exposed to rain or moisture, does not operate normally, or has been dropped.
- Do not use strong or abrasive detergents when cleaning the device body.
- Use only accessories recommended by Avigilon.

Regulatory Notices

This device complies with part 15 of the FCC Rules. Operation is subject to the following two conditions: (1) this device may not cause harmful interference, and (2) this device must accept any interference received, including interference that may cause undesired operation.

This Class B digital apparatus complies with Canadian ICES-003.

This equipment has been tested and found to comply with the limits for a Class B digital device, pursuant to Part 15 of the FCC rules. These limits are designed to provide reasonable protection against harmful interference in a residential installation. This equipment generates, uses and can radiate radio frequency energy and, if not installed and used in accordance with the instructions, may cause harmful interference to radio communications. However, there is no guarantee that interference will not occur in a particular installation. If this equipment does cause harmful interference to radio or television reception, which can be determined by turning the equipment off and on, the user is encouraged to try to correct the interference by one or more of the following measures:

- Reorient or relocate the receiving antenna.
- Increase the separation between the equipment and the receiver.
- Connect the equipment into an outlet on a circuit different from that to which the receiver is connected.
- Consult the dealer or an experienced radio/TV technician for help.

Changes or modifications made to this equipment not expressly approved by Avigilon Corporation or parties authorized by Avigilon Corporation could void the user's authority to operate this equipment.

Disposal and Recycling Information

When this product has reached the end of its useful life, please dispose of it according to your local environmental laws and guidelines.

Risk of fire, explosion, and burns. Do not disassemble, crush, heat above 100 °C (212 °F), or incinerate.

European Union:



This symbol means that according to local laws and regulations your product should be disposed of separately from household waste. When this product reaches its end of life, take it to a collection point designated by local authorities. Some collection points accept products for free. The separate collection and recycling of your product at the time of disposal will help conserve natural resources and ensure that it is recycled in a manner that protects human health and the environment.

Legal Notices

© 2019, Avigilon Corporation. All rights reserved. AVIGILON, the AVIGILON logo, AVIGILON CONTROL CENTER, and ACC are trademarks of Avigilon Corporation. ONVIF is a trademark of Onvif, Inc. Other names or logos mentioned herein may be the trademarks of their respective owners. The absence of the symbols™ and ® in proximity to each trademark in this document or at all is not a disclaimer of ownership of the related trademark. Avigilon Corporation protects its innovations with patents issued in the United States of America and other jurisdictions worldwide (see avigilon.com/patents). Unless stated explicitly and in writing, no license is granted with respect to any copyright, industrial design, trademark, patent or other intellectual property rights of Avigilon Corporation or its licensors.

Disclaimer

This document has been compiled and published using product descriptions and specifications available at the time of publication. The contents of this document and the specifications of the products discussed herein are subject to change without notice. Avigilon Corporation reserves the right to make any such changes without notice. Neither Avigilon Corporation nor any of its affiliated companies: (1) guarantees the completeness or accuracy of the information contained in this document; or (2) is responsible for your use of, or reliance on, the information. Avigilon Corporation shall not be responsible for any losses or damages (including consequential damages) caused by reliance on the information presented herein.

Avigilon Corporation
avigilon.com

PDF-H4PTZ-DC-A

Revision: 4 - EN

20191224

Table of Contents

Overview	1
Front View	1
Side View	2
Installation	4
Camera Package Contents	4
Installation Steps	4
Preparing the Camera for Installation	4
(Optional) Configuring SD Card Storage	6
(Optional) Cutting the Mounting Hole	6
(Optional) Attaching the Back Panel for Plenum Installation	7
Connecting Cables	8
Initializing a Camera Username and Password	9
Assigning an IP Address	10
Accessing the Live Video Stream	10
Mounting the PTZ Dome Camera	11
Installing the Dome Cover	12
For More Information	12
Cable Connections	13
Connecting External Power	13
Connecting to External Devices	13
Connecting to Microphones, Speakers, and Video Monitors	14
Setting the Home Preset Position	16
Manually Returning to the Home Position	16
Automatically Returning to the Home Position	16
Connection Status LED Indicator	18
Resetting to Factory Default Settings	19
Setting the IP Address Using the ARP/Ping Method	20
Cleaning	21
Dome Bubble	21
Body	21
Limited Warranty and Technical Support	22

Overview

Front View

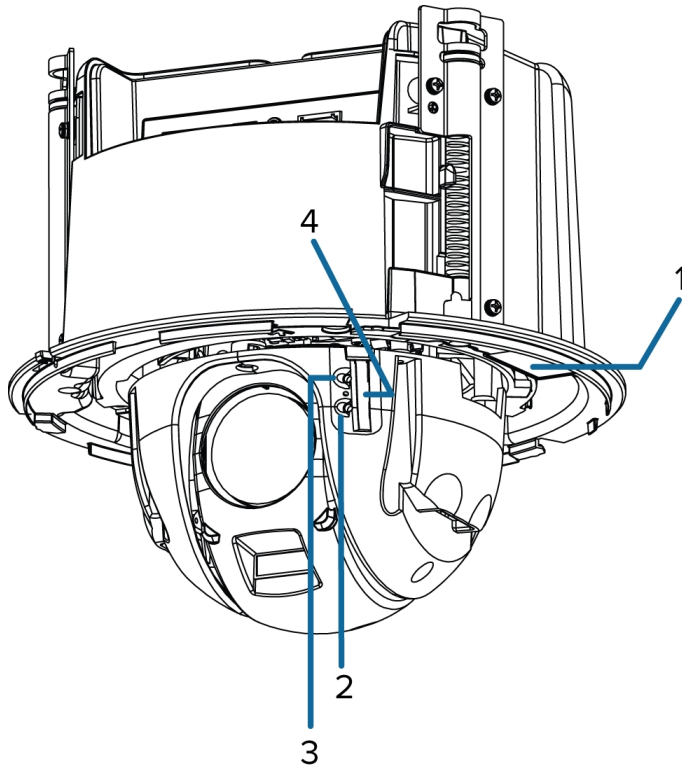

1. **Serial number tag**

Device information, product serial number and part number label.

2. **Connection status LED indicator**

Provides information about device operation. For more information, see *Connection Status LED Indicator* on page 18.

3. **Link LED indicator**

Indicates if there is an active connection in the Ethernet port.

4. **SD card slot**

Accepts an SD card for onboard storage.

Side View

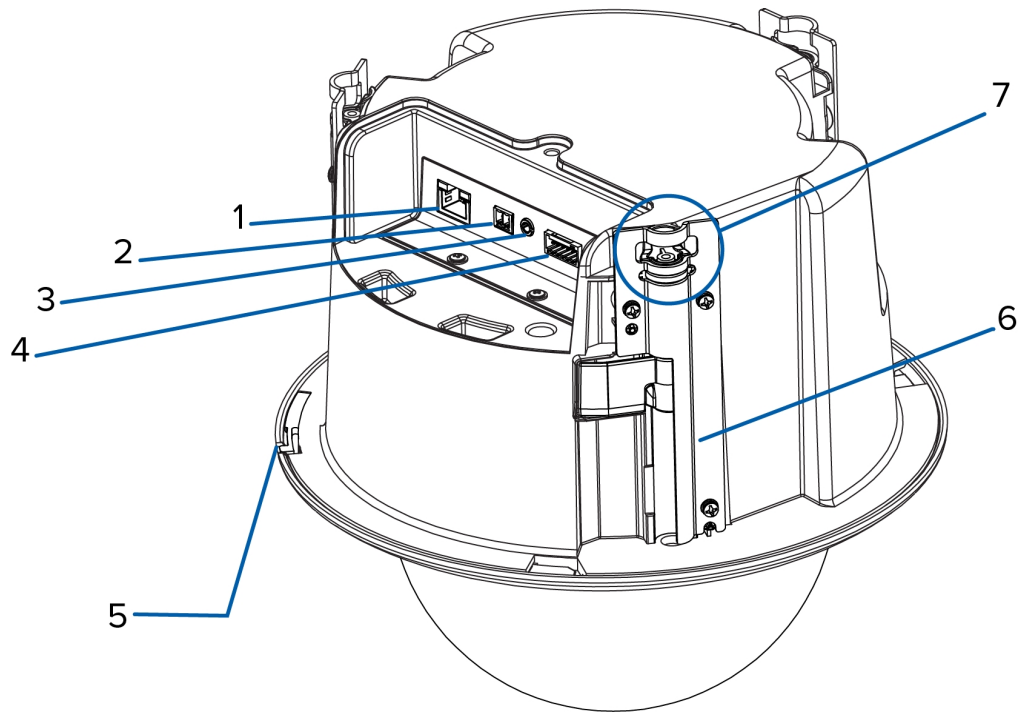

1. Ethernet port

Accepts an Ethernet connection to a network. Server communication and image data transmission occurs over this connection. Also receives power when it is connected to a network that provides Power over Ethernet.

2. Power connector block

Accepts a terminal block with either an AC or DC power connection. DC input can be either polarity. Only required when Power over Ethernet is not available.

3. Audio/video connector

Accepts a mini-jack connector (3.5 mm).

4. I/O connector block

Provides connections to external input/output devices.

5. Cover release tab

Allows you to release and remove the dome cover.

6. Clamps

Spring loaded locking mechanisms that secure the camera to the mounting surface.

7. **Lanyard anchor**

Safety lanyards can attach to anchors at the top of each clamp to help prevent the camera from falling.

Installation

Camera Package Contents

Ensure the camera package contains the following:

- Avigilon H4 PTZ Dome Camera
- Back panel
- Mounting template sticker
- Terminal block
- I/O connector block

Installation Steps

Complete the following sections to install the device.

Preparing the Camera for Installation

Note: Be careful not to scratch the dome bubble.

1. Place the camera on a flat surface with the dome facing up.
2. Press the cover release tab and twist the dome cover until it is released from the base.

The dome cover can only move in one direction.

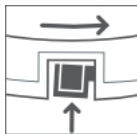

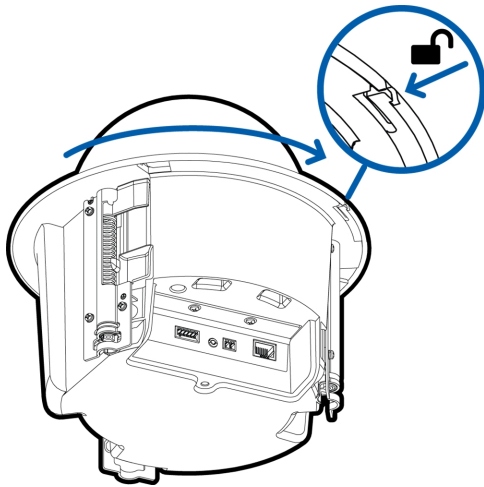

3. Remove the protective material inside the dome cover.

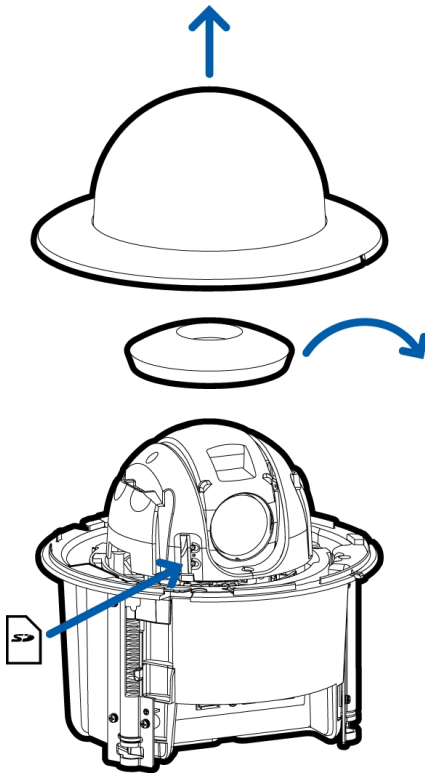

4. If you are planning to use onboard storage, insert an SD card into the SD card slot on the PTZ camera. For more information, see *(Optional) Configuring SD Card Storage* on the next page.

5. Use a screw driver to push each of the clamps into the dome camera until the spring is fully compressed, then turn the clamp into the ready position.

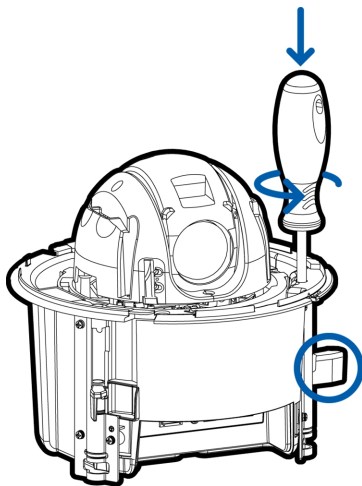
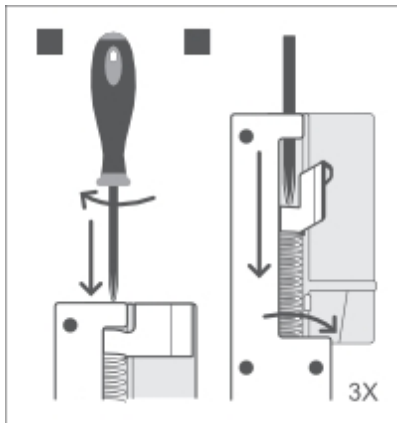

(Optional) Configuring SD Card Storage

To use the camera's SD card storage feature, you must insert an SD card into the card slot.

It is recommended that the SD card have a capacity of 8 GB or more and a write speed of class 610 or better. If the SD card does not meet the recommended capacity or write speed, the recording performance may suffer and result in the loss of frames or footage.

1. Insert an SD card into the camera.



CAUTION — Do not force the SD card into the camera or you may damage the card and the camera. The SD card can only be inserted in one direction.

2. Access the camera's web interface to enable the onboard storage feature. For more information, see the *Avigilon High Definition H4 and H5 IP Camera Web Interface User Guide*.

(Optional) Cutting the Mounting Hole

This procedure is not required if you are planning to install the camera with a metal ceiling panel.

1. Use the mounting template to cut a hole in the mounting surface.

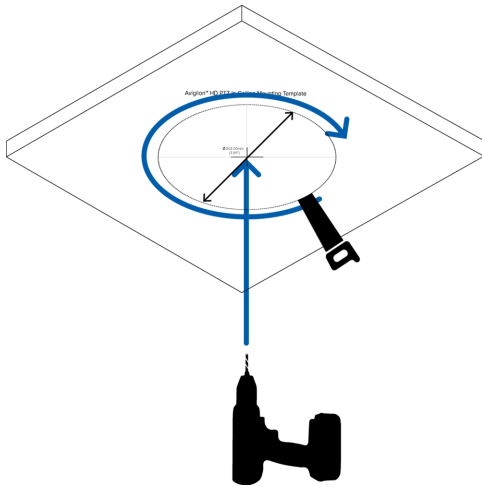

2. Remove the mounting template and pull the required cables through the mounting hole.

(Optional) Attaching the Back Panel for Plenum Installation

If you are installing the dome camera into a plenum space, install the back panel.

1. Attach a conduit connector to the cable entry hole on the back panel. Install the conduit and its fitting as instructed by the manufacturer.
2. Pull the required cables through the conduit, then through the cable entry hole in the back panel.

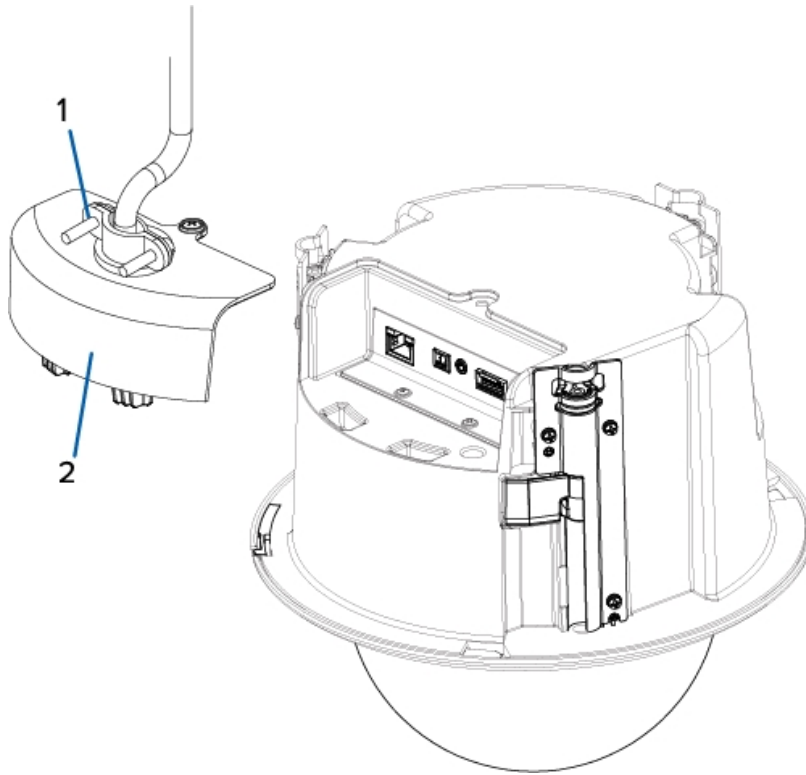

Figure 1: Cables going through the conduit connector (1) and the back panel (2).

3. After you make the cable connections, screw the back panel into place.

Connecting Cables

Refer to the diagrams in the Overview section for the location of the different connectors.

To connect the cables required for proper operation, complete the following:

1. If external input or output devices are part of the installation (for example: door contacts, relays, etc.), connect the devices to the I/O connector block.
2. If an external microphone or external video monitor needs to be connected to the camera, connect the devices to the camera Audio/Video Connector.
3. Connect power using one of the following methods:
 - Power over Ethernet (PoE) Plus IEEE 802.3at Class 4 — Connect a PoE Plus compliant injector or switch to the Ethernet network cable.
 - External Power — Connect an external “Class 2” or “LPS” or “Limited Power Source” with output rated 24 VAC +/- 10%, 32 VA minimum or 24 VDC +/- 10%, 23 W minimum.

Note: The PTZ will move as the camera powers up. It will stop when it has completed its startup procedures.

4. Connect a network cable to the Ethernet port (RJ-45 connector).

The Link LED indicator will turn on once a network link has been established.

5. Check that the Connection Status LED indicator indicates the correct state. For more information, see *Connection Status LED Indicator* on page 18.

Initializing a Camera Username and Password

Cameras manufactured after January 1, 2020, do not have a default username or password and will be in a factory default state.

Important: You must create a user with *administrator* privileges before the camera is operational.

The first user can be created using any of the following methods:

- Camera's Web Interface: enter the camera's IP address in a web browser to access the web interface. If the camera is in the factory default state you will be redirected to the Add a new user page to create the first user. For more information, see the *Avigilon High Definition H4 and H5 IP Camera Web Interface User Guide*.
- Camera Configuration Tool version 1.4.4 or later: cameras discovered in the factory default state will be identified by . Select the **Admin Users** tab to create the first user. For more information, see the *Avigilon Camera Configuration Tool User Guide*.
- USB Wi-Fi Adapter: when connecting a camera in the factory default state, you will be redirected to the Create Administrator User page to create the first user. For more information, see *Avigilon USB Wi-Fi Adapter System User Guide*.
- Avigilon Control Center software version 7.4 or later, or version 6.14.12 or later: when connecting a camera in the factory default state, the client software will ask you to create a new user. For more information, see the *Avigilon Control Center Client User Guide*.
- Avigilon Blue service v3.0 or later: when adding a camera you will be asked to create a new user for cameras in the factory default state. For more information, see the *Avigilon Blue Subscriber or Dealer User Guides*.

Tip: If you are connecting your Avigilon camera to a 3rd party VMS, you will need to set up the first user through the camera's Web Interface, Camera Configuration Tool, or USB Wifi Adapter before you connect to the 3rd party VMS.

Assigning an IP Address

The camera automatically obtains an IP address when it is connected to a network.

Note: If the camera cannot obtain an IP address from a DHCP server, it will use Zero Configuration Networking (Zeroconf) to choose an IP address. When set using Zeroconf, the IP address is in the 169.254.0.0/16 subnet.

The IP address settings can be changed using one of the following methods:

- Camera's web browser interface: `http://<camera IP address>/`
- Network video management software application (for example, Avigilon Control Center (ACC)[™] software).
- ARP/Ping method. For more information, see *Setting the IP Address Using the ARP/Ping Method* on page 20.

Note:

Depending on the manufacture date of your camera, you will have one of the two options below to log in for the first time:

- Cameras manufactured after January 1, 2020: these cameras do not have a default username or password and will be in a factory default state. **You must create a user with administrator privileges before the camera is operational.** For more information, see *Initializing a Camera Username and Password* on the previous page.
- Cameras manufactured before January 1, 2020: login to the camera using the default username of `administrator` with no password. It is recommended that you change the password after your first login.

Accessing the Live Video Stream

Live video stream can be viewed using one of the following methods:

- Web browser interface: `http://<IP address>/`
- Network video management software application (for example, the Avigilon Control Center software).

Note:

Depending on the manufacture date of your camera, you will have one of the two options below to log in for the first time:

- Cameras manufactured after January 1, 2020: these cameras do not have a default username or password and will be in a factory default state. **You must create a user with administrator privileges before the camera is operational.** For more information, see *Initializing a Camera Username and Password* on page 9.
- Cameras manufactured before January 1, 2020: login to the camera using the default username of `administrator` with no password. It is recommended that you change the password after your first login.

Mounting the PTZ Dome Camera

After the cable connections have been made, mount the PTZ dome camera.

1. (Recommended) Attach a safety lanyard from the mounting surface to each of the lanyard anchors to help prevent the camera from falling.
2. Push the PTZ dome camera into the mounting hole.
3. Use a screw driver to release the clamps to secure the camera into place.

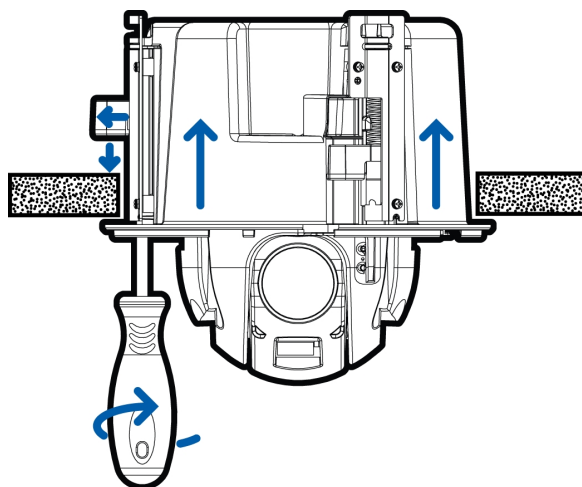
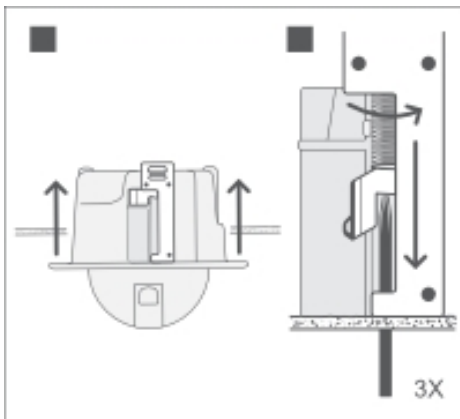
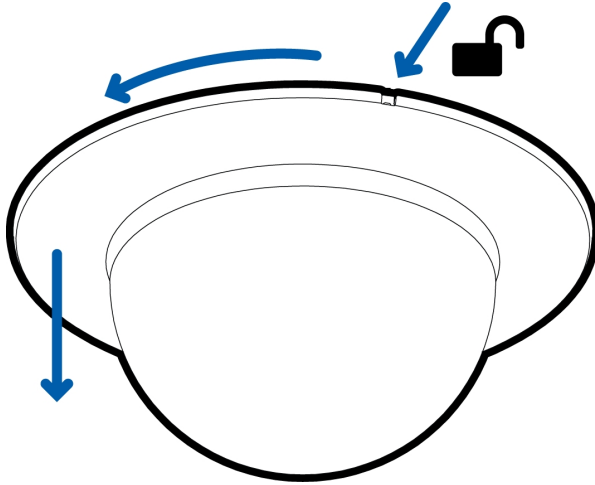

Figure 2: Releasing the clamp from ready position.

Installing the Dome Cover

1. Align the notches on the dome cover with the release tab on the base. The dome cover should be flush against the camera base.



2. Slide the dome cover clockwise until it locks into place.

Note: Be careful not to scratch the dome bubble.

For More Information

Additional information about setting up and using the device is available in the following guides:

- *Avigilon Control Center Client User Guide*
- *Web Interface User Guide — Avigilon High Definition H4 and H5 IP Cameras*
- *Avigilon USB Wi-Fi Adapter System User Guide*
- *Avigilon Camera Configuration Tool User Guide*
- *Designing a Site with Avigilon Video Analytics*

These guides are available on help.avigilon.com and on the Avigilon website: avigilon.com/support-and-downloads.

Cable Connections

Connecting External Power

If PoE is not available, the camera needs to be powered through the removable power connector block. Refer to the diagrams in this guide for the location of the power connector block.

The power consumption information is listed in the product specifications.

To connect power to the power connector block, complete the following steps:

1. Remove the power connector block from the camera.
2. Remove the insulation from ¼" (6 mm) of the power wires. Do not nick or damage the wires.
3. Insert the two power wires into the two terminals on the power connector block. The connection can be made with either polarity.

Use a small slotted (5/64" or 2 mm blade width) screwdriver to loosen and tighten the terminals.

4. Attach the power connector block back into the camera.



WARNING — This product is intended to be supplied by a UL Listed Power Unit marked “Class 2” or “LPS” or “Limited Power Source” with output rated 24 V AC +/- 10%, 32 VA min. or 24 V DC +/- 10%, 23 W min.

Connecting to External Devices

External devices are connected to the camera through the I/O terminal block. The pinout for the I/O terminal block is shown in the following diagram:

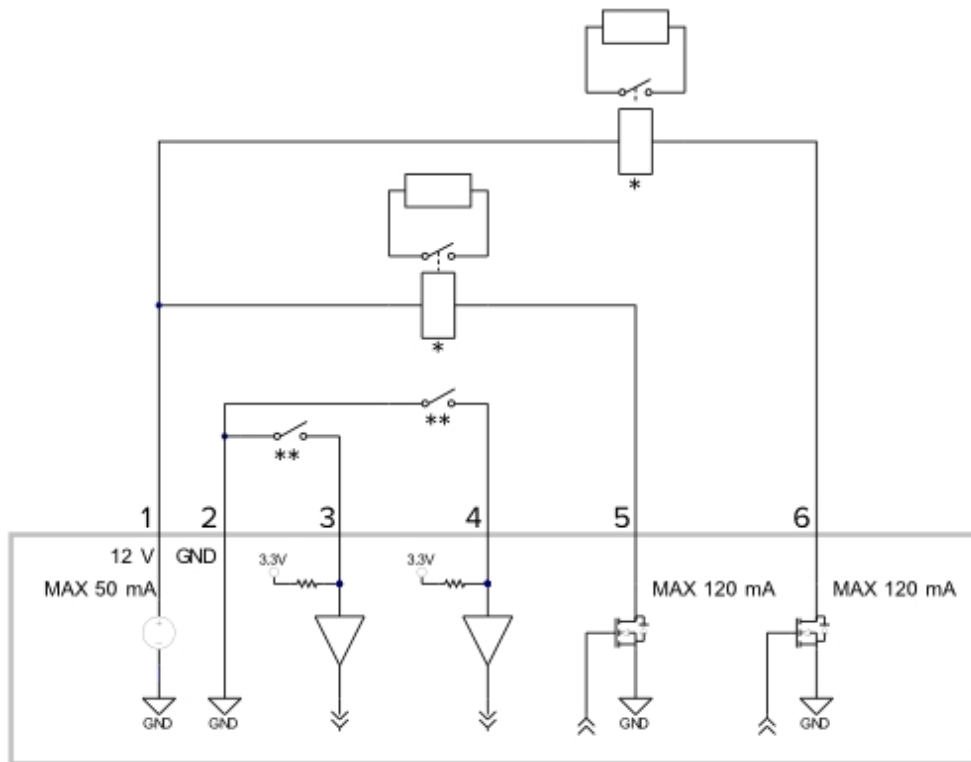

Figure 3: Example application.

1. +12 VDC, 50 mA max. output for relay drive
 2. Relay ground return
 3. Relay input 1
 4. Relay input 2
 5. Relay Output 1
 6. Relay Output 2
- * — Relay
 - ** — Switch

Note: The 12 V connection can be used to energize a relay coil with up to 50 mA. If more than 50 mA is required, an external power supply up to 25 VDC at 120 mA can be used.

Connecting to Microphones, Speakers, and Video Monitors

The camera can be connected to an external microphone, speaker and video monitor through the mini-jack (3.5 mm) audio/video connector (Avigilon part number CM-AC-AVIO1).

Only the 2.0 megapixel models can be connected to an external video monitor through the A/V connector.

Note: The camera only supports line level mono audio input and an NTSC or PAL video output.

The video output signal is determined by the camera flicker control setting. When the camera flicker control is set to 60 Hz, the video output signal is NTSC. When the flicker control is set to 50 Hz, the video output signal is PAL. Use the Camera Installation Tool to configure the camera's flicker control in the Image and Display setup.

The pinout for the connector is shown in the following diagram:

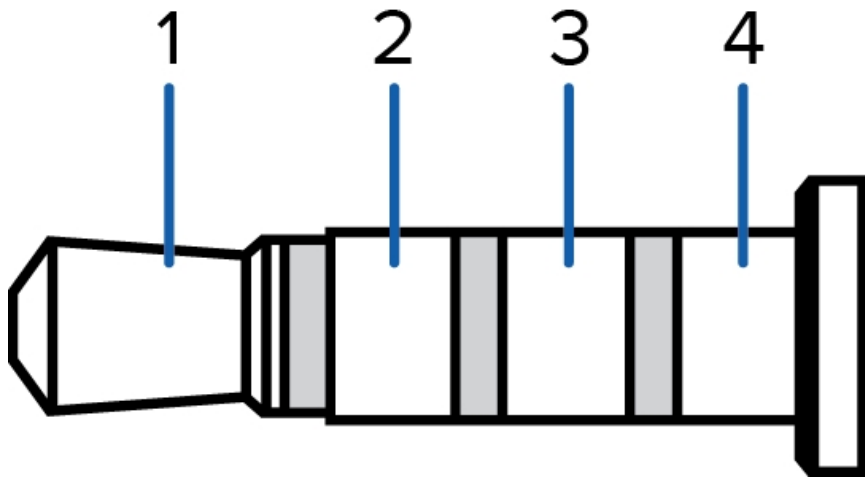

The wiring for the connector pinout is shown in the following table:

Pin	Purpose	Wire
1	Audio IN	Red
2	Composite Video OUT	Black
3	GND	Yellow
4	Audio OUT	Green

Setting the Home Preset Position

The PTZ camera supports self-learning video analytics from the home preset position. The home preset position is typically the field of view the PTZ camera returns to after being used for investigations.

Before you can configure the camera's home position, you must connect the camera to a site in the ACC™ Client software. For more information about adding cameras to a site and the following steps, see the *Avigilon Control Center Client User Guide*.

To set the home preset position, display the live video from the PTZ camera then complete the following steps:

Tip: Name the preset position "Home" so that it will be easy to find when configuring the camera for other applications.

1. Move the camera's field of view into position.
2. In the **Presets** drop-down list, select a number then click .
3. In the dialog box, enter a name for the preset.
4. Select the **Set as home preset** check box if you want this to be the camera's Home preset.
5. Click **OK**.

After you've set the camera's home preset position, you can configure the required video analytics events in the ACC Client software.

Manually Returning to the Home Position

After the home preset position has been configured, you can set the PTZ camera to return to the configured field of view by clicking .

Automatically Returning to the Home Position

You can also configure the PTZ camera to automatically return to the home preset position after the camera is left idle for a set amount of time. This can be configured in two ways: through a PTZ tour or a rule.

A PTZ tour can be configured from the camera web interface or in the ACC Client software. To configure the PTZ camera to automatically return to the home position, create a new tour and add only the home position to the preset list. Next, select the **Set as default tour** check box and use the **Default Tour Idle Start Time (Minutes)** field to define the expected amount of idle time before the camera returns to the home position.

To use the rule method, you must have an Enterprise Edition or Standard Edition version of the Avigilon Control Center system. To configure the PTZ camera to automatically return to the home position, create a rule that includes the following settings:

- On the Select Rule Event(s) page, select **PTZ idle**.
- On the Select Rule Action(s) page, select **Go to Home Preset**.

Connection Status LED Indicator

Once connected to the network, the Connection Status LED indicator will display the progress in connecting to the Network Video Management software.

The following table describes what the LED indicator shows:

Connection State	Connection Status LED Indicator	Description
Obtaining IP Address	One short flash every second	Attempting to obtain an IP address.
Discoverable	Two short flashes every second	Obtained an IP address but not connected to the Network Video Management software.
Upgrading Firmware	Two short flashes and one long flash every second	Updating the firmware.
Connected	On	Connected to the Network Video Management software or an ACC™ Server. The default connected setting can be changed to Off using the camera's web user interface. For more information see the <i>Avigilon High Definition H4 and H5 IP Camera Web Interface User Guide</i> .

Resetting to Factory Default Settings

If the device no longer functions as expected, you can choose to reset the device to its factory default settings.

Use the firmware revert button to reset the device. The firmware revert button is shown in the following diagram:

Note: Be careful not to scratch the dome bubble.

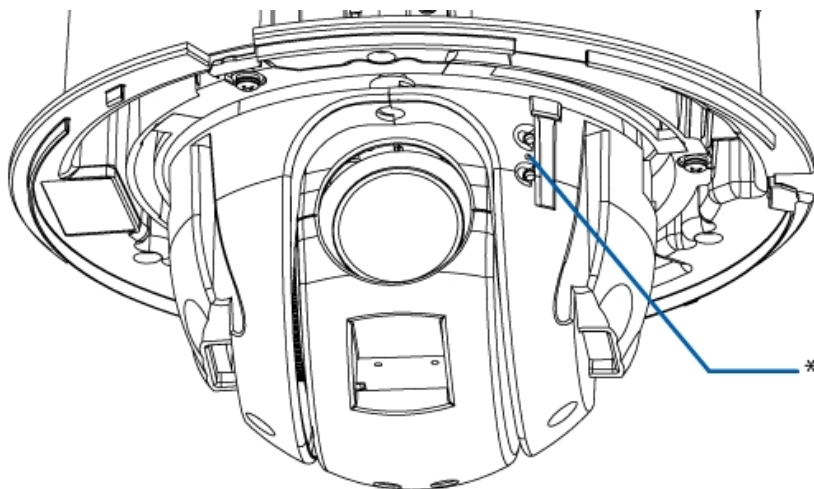

Figure 4: The firmware revert button between the status LEDs.

1. Ensure the camera is powered on.
2. Remove the dome cover.
3. Using a straightened paperclip or similar tool, gently press and hold the firmware revert button for two seconds.
4. Re-install the dome cover.



CAUTION — Do not apply excessive force. Inserting the tool too far may damage the camera.

Setting the IP Address Using the ARP/Ping Method

Complete the following steps to configure the camera to use a specific IP address:

1. Locate and copy down the MAC Address (MAC) listed on the Serial Number Tag for reference.

2. Open a Command Prompt window and enter the following commands:

- a. `arp -s <New Camera IP Address> <Camera MAC Address>`

For example: `arp -s 192.168.1.10 00-18-85-12-45-78`

- b. `ping -l 123 -t <New Camera IP Address>`

For example: `ping -l 123 -t 192.168.1.10`

3. Reboot the camera.

4. Close the Command prompt window when you see the following message:

Reply from <New Camera IP Address>: ...

Cleaning

Dome Bubble

If the video image becomes blurry or smudged in areas, it may be because the dome bubble requires cleaning.

To clean the dome bubble:

- Use hand soap or a non-abrasive detergent to wash off dirt or fingerprints.
- Use a microfiber cloth or non-abrasive fabric to dry the dome bubble.

Important: Failure to use the recommended cleaning materials may result in a damaged or scratched dome bubble. A damaged dome bubble may negatively impact image quality and cause unwanted IR light reflecting into the lens.

Body

- Use a dry or lightly dampened cloth to clean the camera body.
- Do not use strong or abrasive detergents.

Limited Warranty and Technical Support

Avigilon warranty terms for this product are provided at [avigilon.com/warranty](https://www.avigilon.com/warranty).

Warranty service and technical support can be obtained by contacting Avigilon Technical Support: [avigilon.com/contact-us/](https://www.avigilon.com/contact-us/).