

EXH RANGE, BRACKETS



EXWB1000

BRACKET AND BALL JOINT FOR EXH EX-PROOF HOUSING

Solid, anticorrosive aluminium construction

The EXBJ, alone, allows the column mount

Load rating: 35kg (77lb)

Length: 455mm (17.9in)

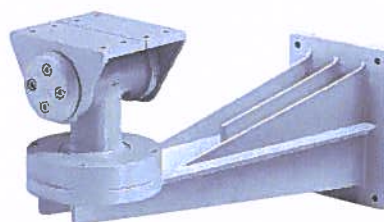

EXWB1000

EXBJ000

BALL JOINT FOR THE COLUMN MOUNT OF EXH EX-PROOF HOUSINGS

Solid, anticorrosive aluminium construction

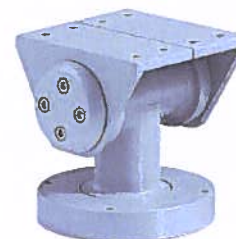

EXBJ000

TECHNICAL DATA

EXWBJ000

MECHANICAL

Solid, anticorrosional aluminium construction

Load rating: 35kg (77lb)

Length: 455mm (17.9in)

Unit weight (EXWBJ): 6.6kg (14.5lb)

PART NUMBER

EXWBJ000 Bracket and ball joint RAL7032 for EXH series

PACKAGE

Model Number	Weight	Dimensions (WxHxL)	Master carton
EXWBJ000	7kg (15.4lb)	27x18x49cm (10.5x7x19in)	-

EXBJ000

MECHANICAL

Solid, anticorrosional aluminium construction

Unit weight: 2.9kg (6.4lb)

PART NUMBER

EXBJ000 Only ball joint for EXH RAL7032 housings

PACKAGE

Model Number	Weight	Dimensions (WxHxL)	Master carton
EXBJ000	3.2kg (7.1lb)	16x21x12cm (6.3x8.3x4.7in)	-

TECHNICAL DRAWINGS

The dimensions of the drawings are in millimetres.

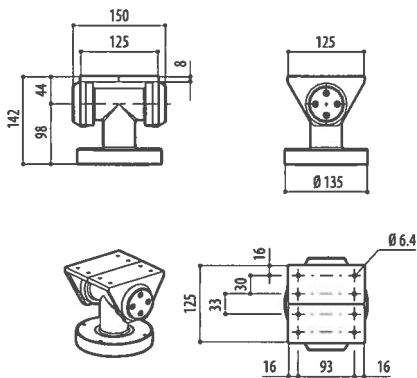

EXBJ

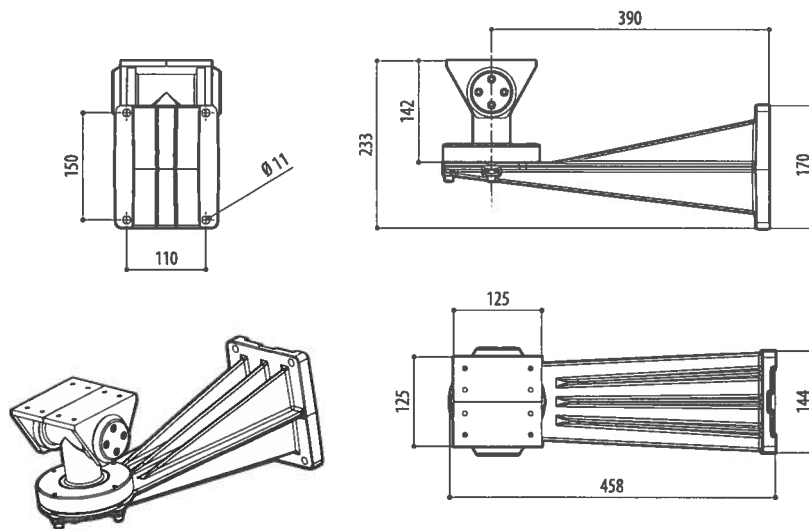

EXWBJ000