

ELECTRADROP

LOCINOX[®]
WWW.LOCINOX.COM

USER GUIDE

- ENGLISH
- NEDERLANDS
- FRANÇAIS
- DEUTSCH



Copyright

Copyright © 2012 Locinox. All rights reserved.

This product incorporates copyright protected technology that is protected by a number of EU patent method claims and other intellectual property rights owned by the Locinox Corporation and other rightholders.

Use of this copyright protected technology must be authorized by the Locinox Corporation. Reverse engineering or disassembly is prohibited. No part of this publication can either be reproduced, communicated, transcribed, stored in a retrieval system or be translated into any language in any form or by any means, whether electronic, mechanical, magnetic, optical, chemical, manual or otherwise, unless explicit written consent has been given by the copyright holder.

Notice

The contents of this publication is subject to change. The company reserves the right to alter the contents of this publication at any time and without notice. The contents of this publication may contain inaccuracies or typographical errors and is supplied for informational use only.

Technical Support

If you require any additional information or assistance during the installation, please contact your dealer, who will be able to provide the latest information. Alternatively, you can visit the Locinox website for more technical information or e-mail us on locinox@locinox.com

- A discarded device can either be returned to your dealer or be sent back to Locinox. This product's recycling fee is € 0,2.



- The WEEE marking on the product indicates that it may not be thrown away together with normal household waste and must be handed over to a designated collection point for the recycling of electrical and electronic rejects.



- As manufacturer of this product, we guarantee that we have taken all the necessary steps in order for this product to comply with the current safety requirements.



Contents

Copyright © 2012 Locinox	03
--------------------------------	----

English

1. Introduction	06
2. Package content & Dimensions	06
3. Characteristics of the Electradrop	07
4. Electrical Specification	08
5. Time circuitry	08
6. Mounting	09
7. Electrical Wiring	09
8. FAQ	12

Nederlands

1. Inleiding	13
2. Pakketinhoud & Dimensions	13
3. Kenmerken van de Electradrop	14
4. Elektrische specificaties	15
5. Tijd schakelschema	15
6. Montage	16
7. Elektrische aansluiting	19
8. FAQ	19

Français

1. Introduction	20
2. Contenu de l'emballage & Dimensions	20
3. Caractéristiques de l'Electradrop	21
4. Spécifications électrique	22
5. Circuits de temps	22
6. Montage	23
7. Câblage électrique	26
8. FAQ	26

Deutsch

1. Einleitung	27
2. Paketinhalt & Abmessungen	27
3. Besonderheiten des Electradrops	28
4. Elektrische Daten	29
5. Zeitschaltung	29
6. Montage	30
7. Elektrische Verbindung	33
8. FAQ	33

Manual - English

1. Introduction

Thank you for choosing a Locinox electrical dropbolt! Please read the following instructions thoroughly before mounting the Electradrop. Enclosed you will find all relevant user information concerning the Electradrop.

2. Package Contents & Dimensions

Please check if your package contains the following items:

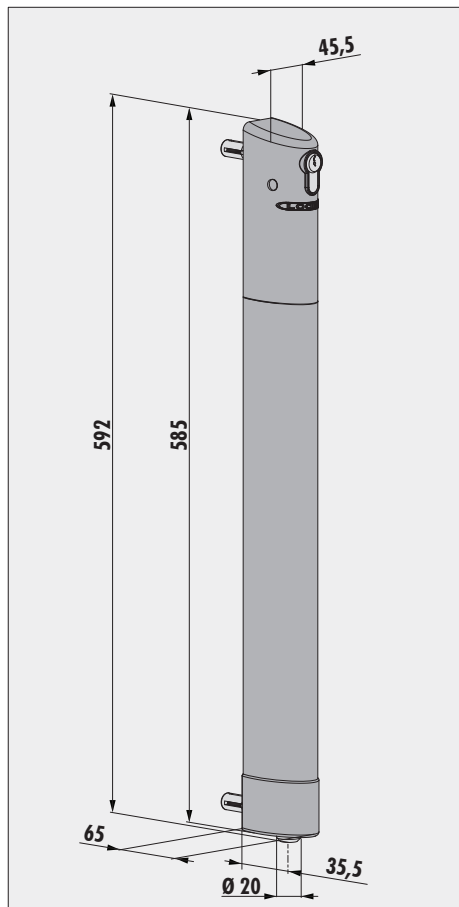

1

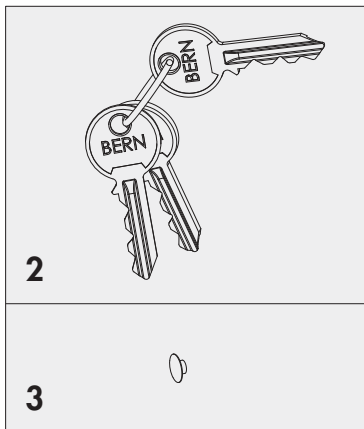

2

3

1	Electrical dropbolt (1x) & connecting cable 5 m with 5 x 0,5 mm ²
2	Cylinder keys (3x)
3	Polyamide cover cap (1x) for cylinder bolt protection

Please contact your supplier should any of the above items be damaged or missing.

3. Characteristics of the Electradrop

- The Electradrop is an automatic drop bolt specially developed for outside use in combination with automatic swing gates.
- The product has a powder-coated aluminium / stainless steel casing and a stainless steel drop-pin.
- Anti - theft and vandalism proof fixing concept.
- Easy emergency opening in case of power failure by unlocking the cylinder. Afterwards, you can slide up the Electradrop 120mm.
- Cylinder type: europrofile cylinder 27/10, (Locinox cylinder code: **3012G21Z**).
- The Electradrop needs to be connected to the warning light (flashing light) output signal. This signal must have a delay of 3 seconds minimum before activating the opening sequence. If the Electradrop receives a pulsing signal: the drop bolt will go down 2 seconds after the signal stops. If the Electradrop receives a continuous control signal: the drop bolt will go down immediately after the control signal stops.
- Throw: 115mm
- Obstacle detection: Once the Electradrop encounters any obstacle in the downward movement, it will automatically stop at this position. The dropbolt develops a downward force of 18kg during his movement.
- Relay output for upper position detection of the bolt (connection position 3-4; 2 black wires of the cable).
- Installation with Locinox groundstop, type OGS.

Throw: 115 mm

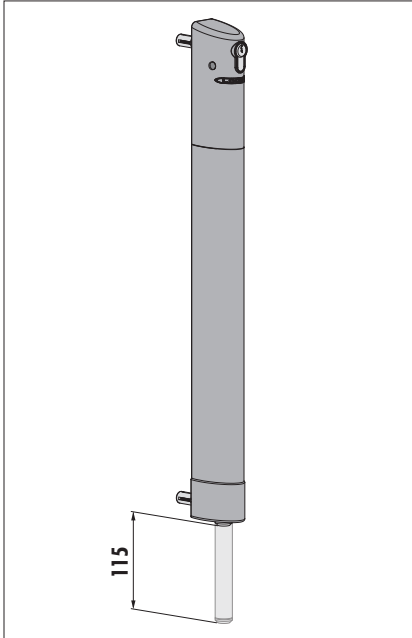

Emergency opening: 120 mm

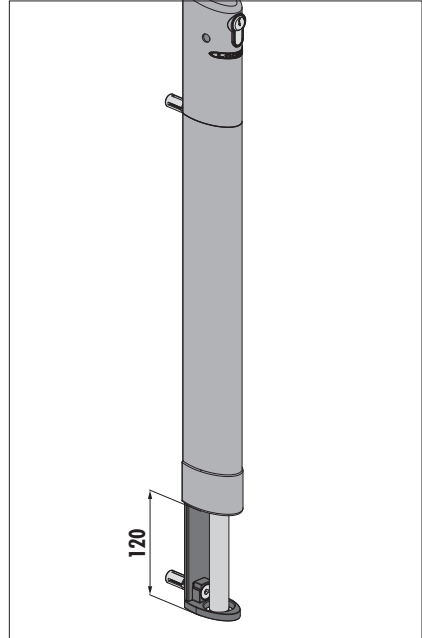

4. Electrical Specification

To connect to a Locinox DC-POWER-24V/25W power supply

Voltage	24V DC (polarity secured)
Power consumption	11 W
Power consumption at rest	0,2 W
Insulation class	□
Maximum switching voltage of the contact (3-4)	200V (DC or peak AC)
Maximum switching current of the contact (3-4)	1A (DC or peak AC)
Maximum switching power of the contact (3-4)	20W (Any DC combination of V and A should not exceed their individual limits.)

5. Time circuitry

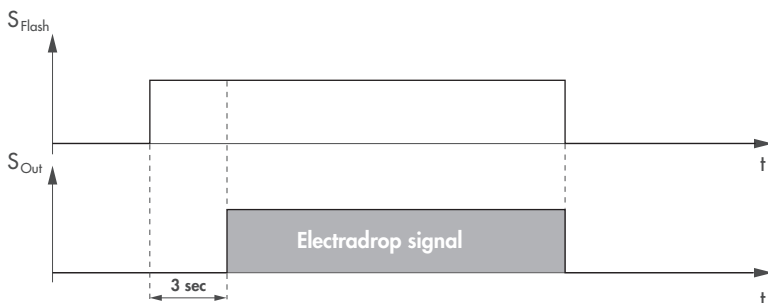
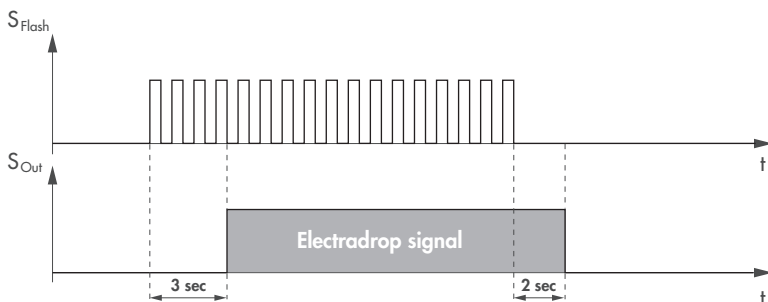

6. Mounting

Step 1: Gate preparation

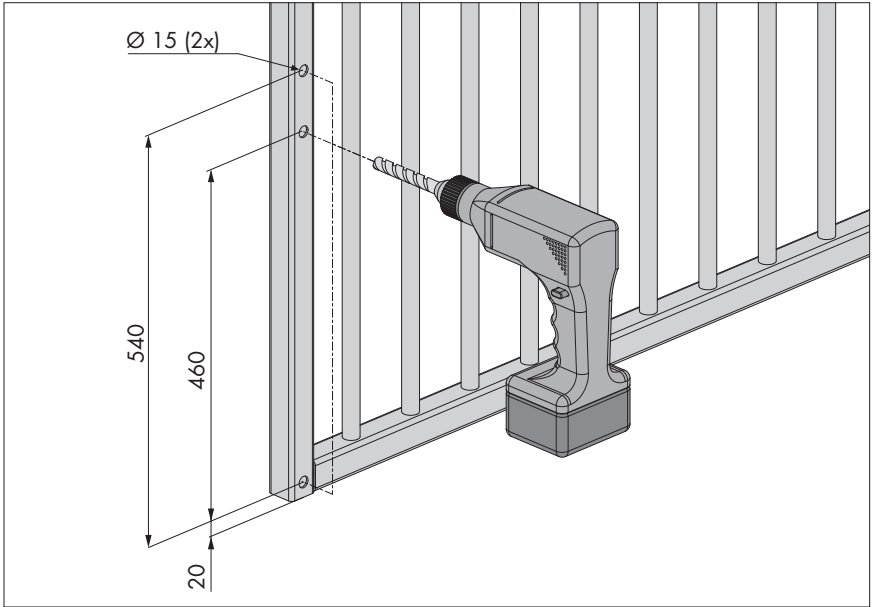

Step 2: Unlock the Electradrop and remove the cylinder

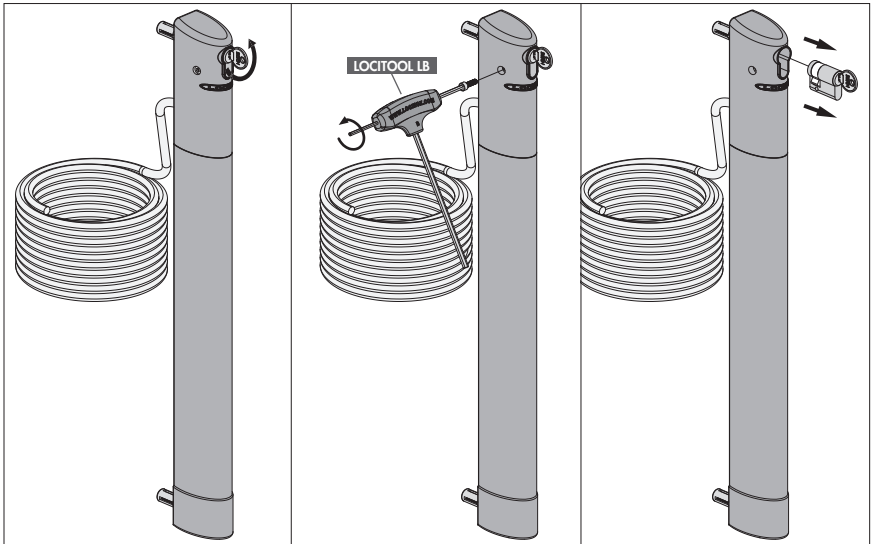

Step 3: Pull the cable through the gate profile



Step 4: Mounting the Electadrop

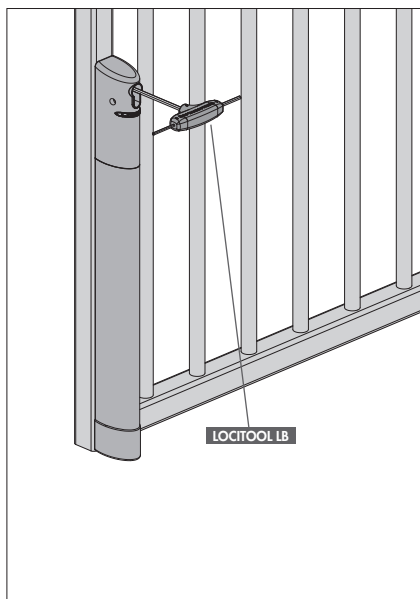
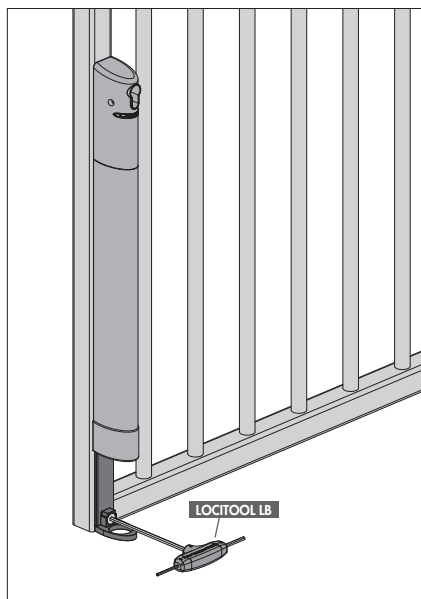

Step 5: Mount the cylinder

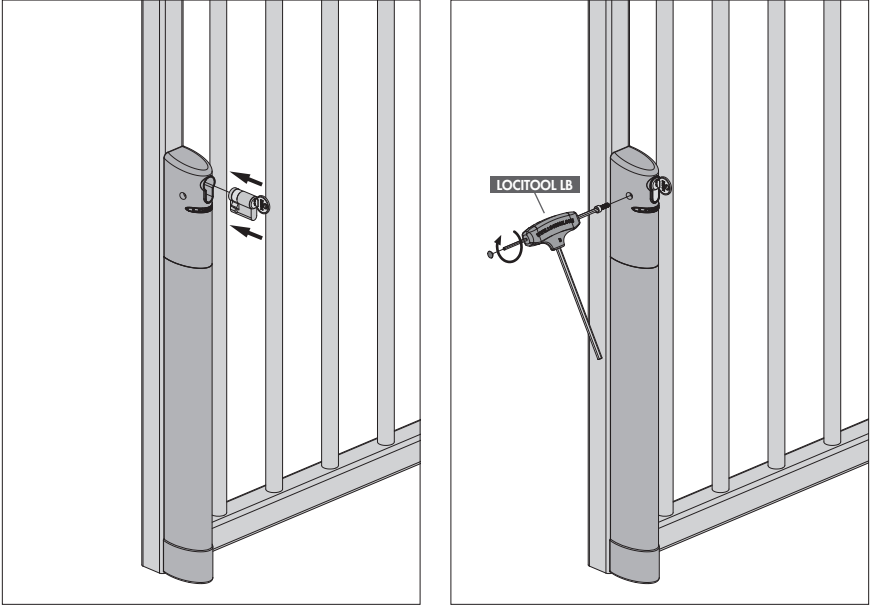

Step 6: Use the Electradrop in combination with the Locinox OGS groundstop

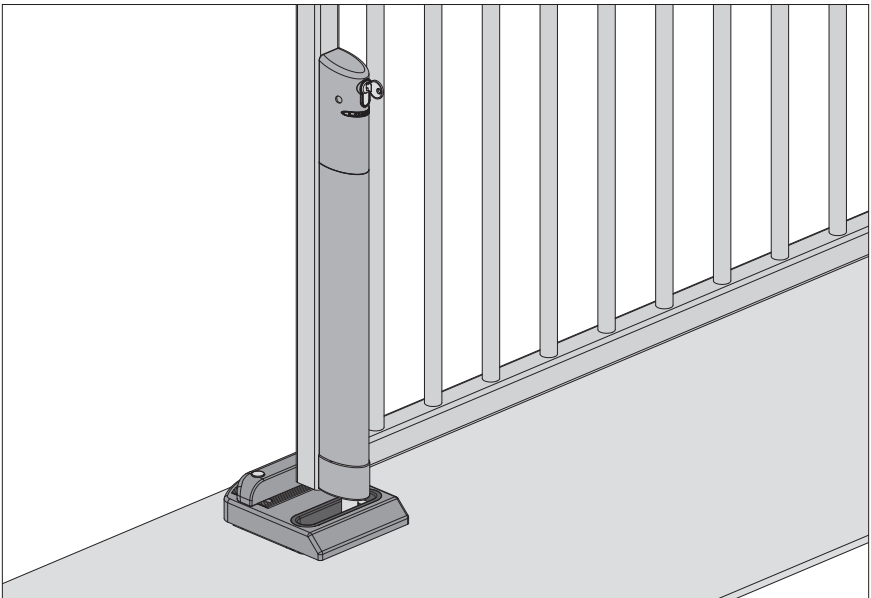

7. Electrical Wiring

⚠ Choice of the relay: The type of relay that needs to be selected depends on the type of flashing light of the system. For example: When you use a 230V flashing light, you should use a relay with a voltage of 230V.

1	Brown	Plus-pole of the power supply 24 V DC (+)
2	Grey	Warning light (flasher) coming from the relay
3	Black	Optional: Reading out the position of the dropbolt.
4	Black (or White)	
5	Blue	Nul-pole of the power supply 0 V DC (-)
Control signal		Connecting parallel over the flashing light of the gate.

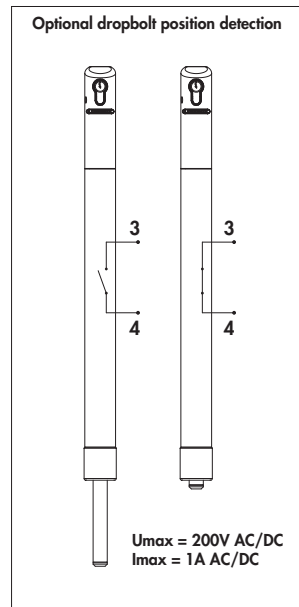
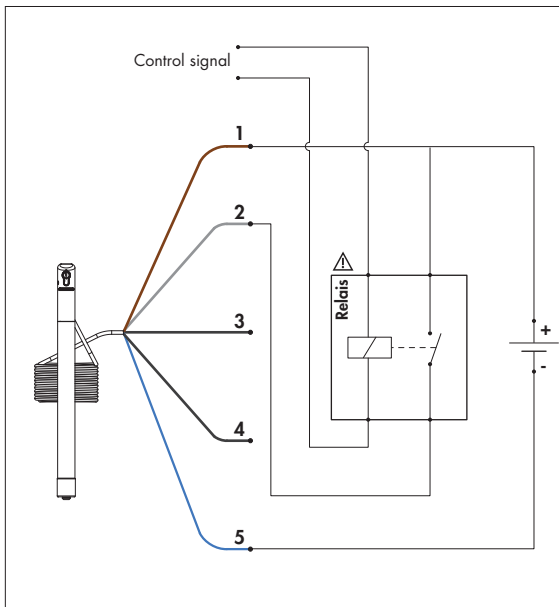

8. FAQ

- What happens if the ground stop is contaminated with eg. sand ?
Due to the internal obstacle detection, the extending bolt of the Electradrop will stop sliding down whenever he encounters an obstacle.
- What happens if the power cable of the Electradrop is cut through ?
The Electradrop will remain in its current position
- In case of power failure, how can I remove the Electradrop ?
The Electradrop can be unlocked by the cylinder so you can slide up the Electradrop afterwards.

Handleiding - Nederlands

1. Inleiding

Bij deze bedanken wij u dat u gekozen hebt voor de Locinox elektrische grondgrendel. Gelieve de bijgevoegde handleiding grondig te lezen en de instructies te volgen vooraleer u de Electradrop monteert. Deze handleiding bevat alle informatie die u nodig hebt voor de installatie en aansluiting van dit product.

2. Pakketinhoud & Dimensies

Controleer of uw Electradrop-pakket volgende items bevat:

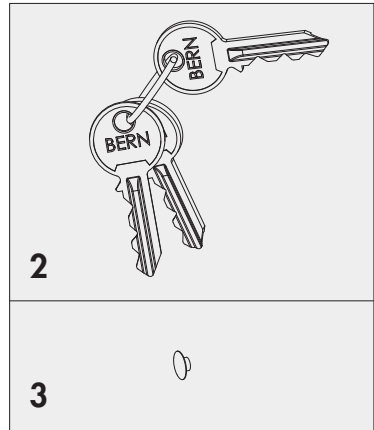
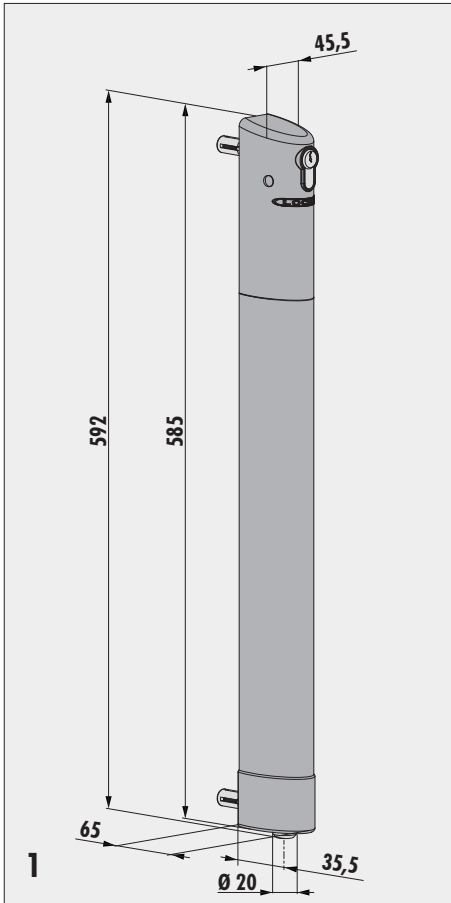

1	Elektrische grondgrendel (1x) & Aansluitkabel 5 m met $5 \times 0,5 \text{ mm}^2$
2	Cilinder sleutels (3x)
3	Polyamide afdekdop (1x) voor de bescherming van de cilinderbout

Indien één van de items beschadigd zou zijn of mocht ontbreken, gelieve dan contact op te nemen met uw verdeler.

3. Kenmerken van de Electradrop

- De Electradrop is een elektrische grondgrendel speciaal ontwikkeld voor buitengebruik in combinatie met geautomatiseerde poorten.
- Het product heeft een poeder coated aluminium/inox behuizing en een inox grendelstang.
- Antidiefstal en vandalisme proof bevestigingssysteem.
- Eenvoudige noodopening bij stroompanne d.m.v. ontgrendeling met cilinder. Waarna men de Electradrop 120mm omhoog kan schuiven.
- Cilinder type: europrofiel cilinder 27/10, (Locinox cilinder code: **3012G21Z**).
- De Electradrop moet verbonden worden met het knipperlichtsignaal aan de sturingsunit van de automatisatie. Een minimum tijdframe van 3 seconden is nodig om de grondgrendelstang op te trekken alvorens de motoren geactiveerd worden. Als de Electradrop een pulserend stuursignaal krijgt gaat de grondgrendel 2 Seconden na het wegvallen van het signaal naar beneden. Als de Electradrop aangesloten is op een continu stuursignaal dan gaat de grondgrendel onmiddellijk naar beneden na het wegvallen van het signaal.
- Vergrendelingsslag: 115mm
- Obstateldetectie: de grendel van de Electradrop stopt op elke willekeurige positie. De grendel ontwikkelt een drukkracht van 18kg bij de neerwaartse beweging.
- Relaisuitgang voor detectie van de grendel in de bovenste positie (aansluiting positie 3-4; 2 zwarte aders van de kabel).
- Installatie met Locinox grondstop, type OGS.

Vergrendelingsslag: 115 mm

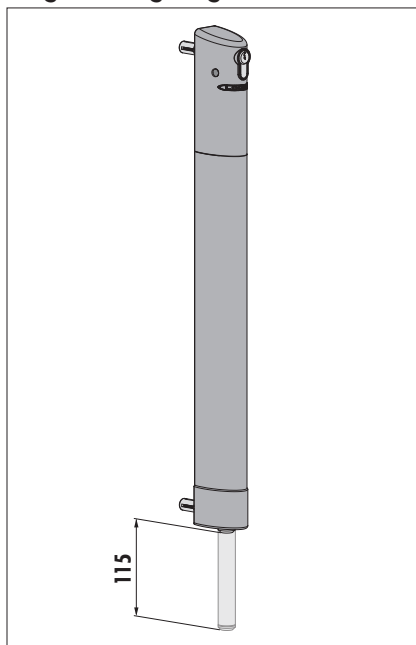

Noodopening: 120 mm

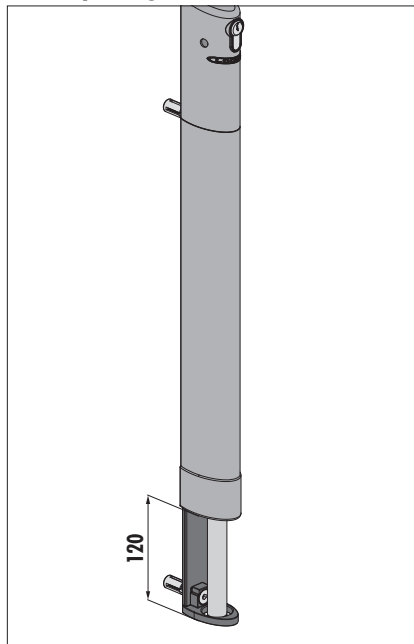

4. Elektrische specificaties

Aan te sluiten op Locinox DC-POWER-24V/25W voeding

Voedingsspanning	24V DC (polariteit beveiligd)
Opgenomen vermogen	11 W (24V/25W DC voeding vereist)
Opgenomen vermogen in rust	0,2 W
Isolatie klasse	□
Maximum te schakelen spanning van het contact (3-4)	200V (DC of piek AC)
Maximum te schakelen stroom van het contact (3-4)	1A (DC of piek AC)
Maximum te schakelen vermogen van het contact (3-4)	20W (Elke DC combinatie van V en A mogen hun individuele maxima niet overschrijden.)

5. Tijd schakelschema

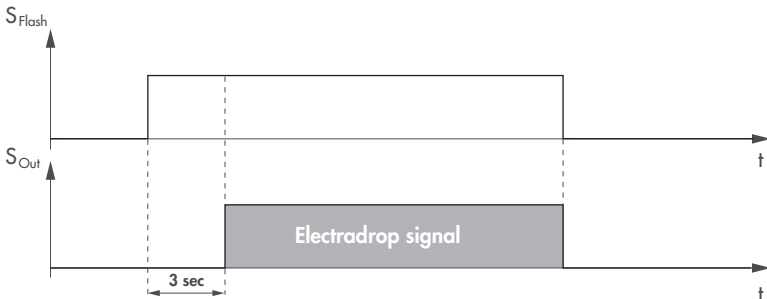
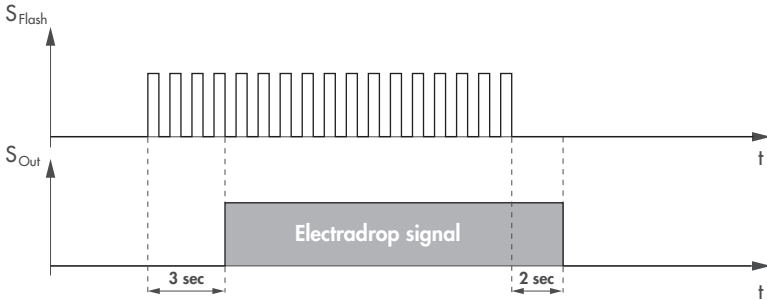

6. Montage

Step 1: Poortvoorbereiding

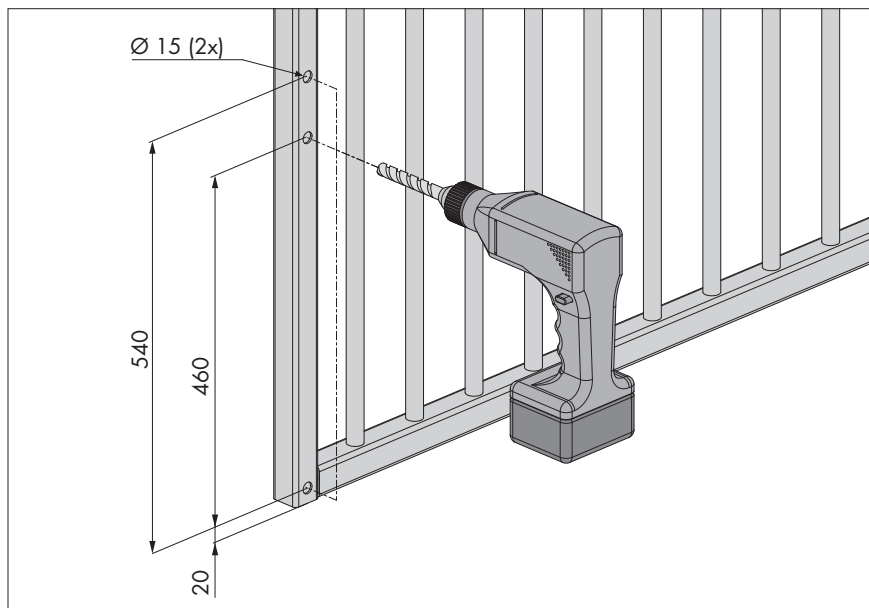

Step 2: Electradrop ontgrendelen en de cilinder verwijderen

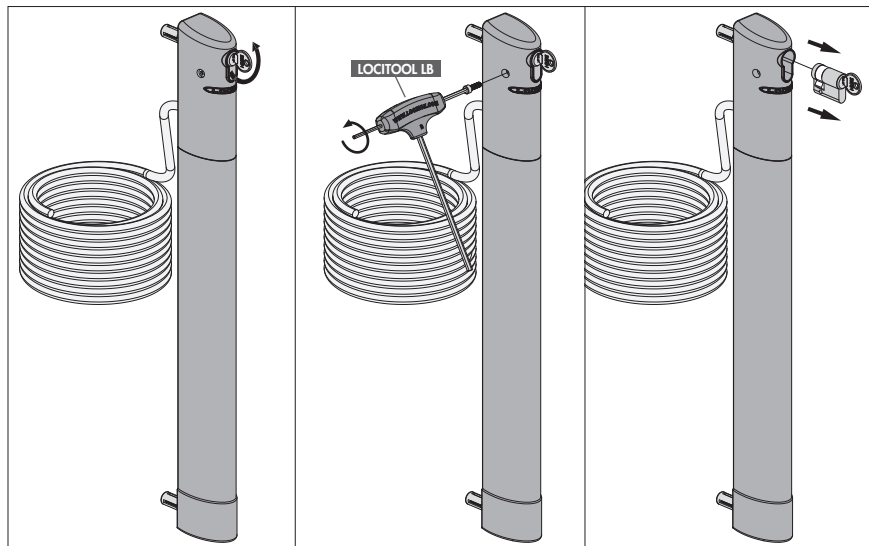

Step 3: Kabel door het poortprofiel



Step 4: Bevestiging van Electradrop

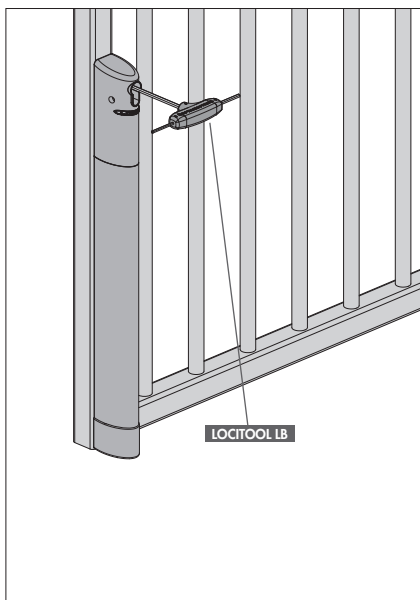
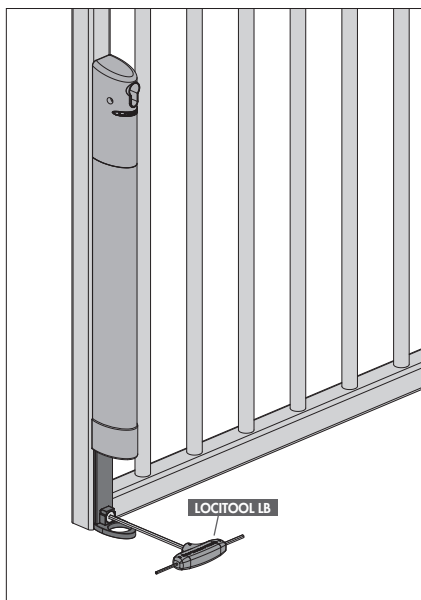

Step 5: Montage van de cilinder

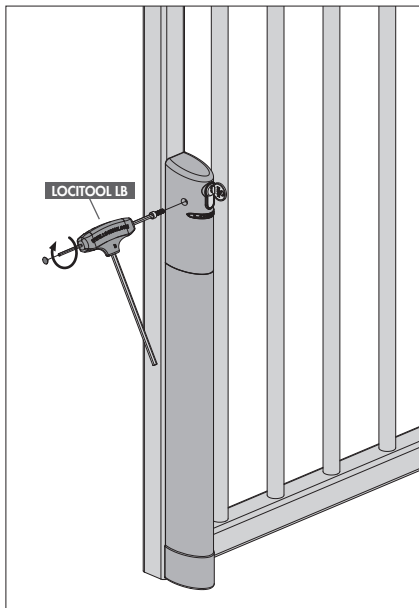

Step 6: Gebruik de electradrop in combinatie met de Locinox OGS

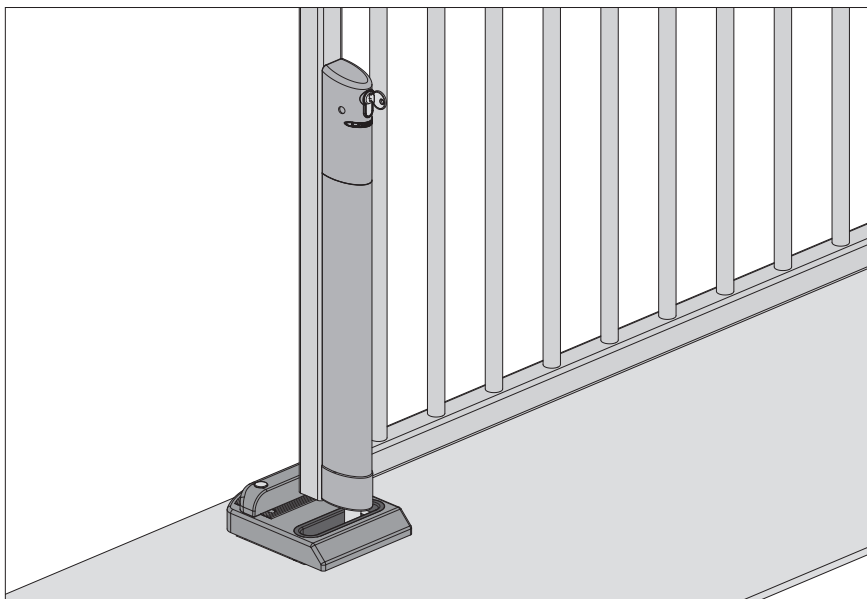

7. Elektrische aansluiting

⚠ Keuze van de relais: Het type relais dat men moet gebruiken is afhankelijk van de knipperlamp van de automatisatie. Bvb. bij een 230V knipperlamp dient men gebruik te maken van een relais met als spoelspanning 230V.

1	Bruin	Plus-klem van de spanningsbron 24 V DC (+)
2	Grijs	Knippersignaal afkomstig van relais
3	Zwart	Optioneel: Grendelpositie uitlezing
4	Zwart (of wit)	
5	Blauw	Nul-klem van de spanningsbron 0 V DC (-)
Stuursignaal		Parallel aansluiten over de knipperlamp van de poort

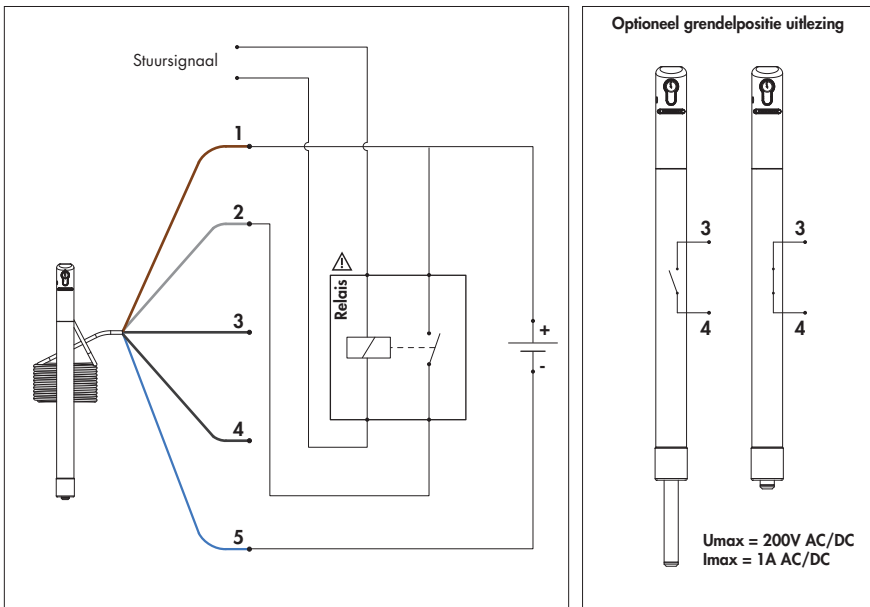

8. FAQ

- Wat gebeurt er als de grondpot vervuild is door bvb zand?
Door de interne obstakeldetectie zal de uitschuivende Electradrop grendel stoppen met uitschuiven als hij een obstakel tegenkomt.
- Wat gebeurt er als de voedingskabel van de Electradrop doorgesneden wordt?
De Electradrop zal in zijn huidige positie blijven staan.
- In geval van stroompanne, hoe kan ik de Electradrop verwijderen?
Men kan de Electradrop ontgrendelen d.m.v. de sleutel waarna men de Electradrop omhoog kan schuiven.

Manuel - Français

1. Introduction

Merci d'avoir choisi un verrou de sol électrique Locinox ! S'il vous plait veuillez lire attentivement les instructions suivantes avant le montage de l'Electradrop. A l'intérieur de ce livret, vous trouverez toutes les informations nécessaires au montage de l'Electradrop.

2. Contenu de l'emballage & Dimensions

Veuillez vérifier si votre emballage contient les éléments suivants:

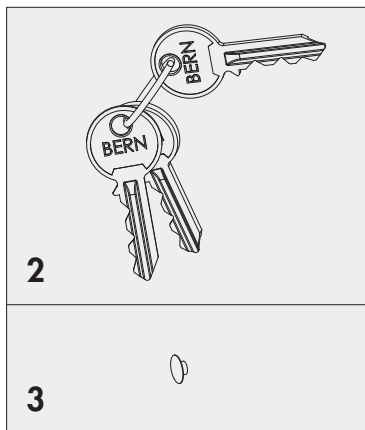
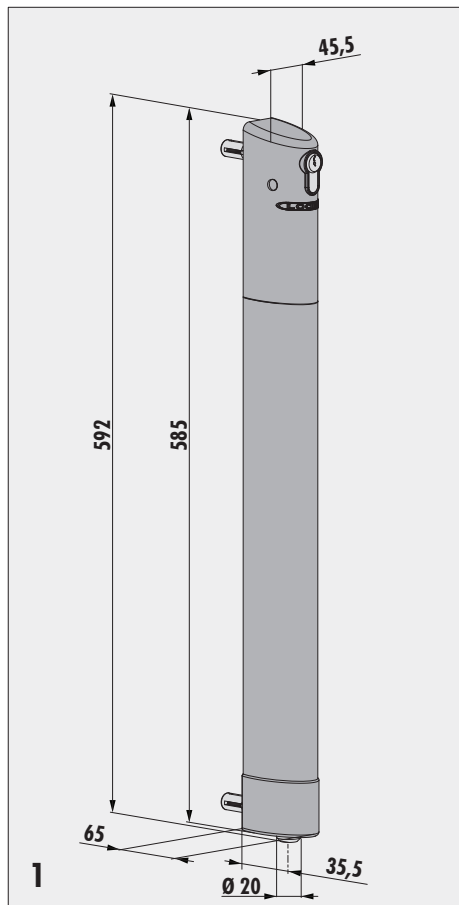

1	Verrou de sol électrique (1x) & Câble électrique de 5m contenant 5 fil de 0,5 mm ²
2	Clés du cylindre (3x)
3	Bouchon plastique en polyamide pour le trou de la vis de fixation du cylindre

S'il vous plait veuillez contacter votre fournisseur si l'un des éléments ci-dessus est endommagé ou manquant.

3. Caractéristiques de l'Electradrop

- L'Electradrop est un verrou de sol électrique spécialement conçu pour une utilisation en extérieur en combinaison avec un automatisme de portail.
- Le produit est équipé d'un coffre thermolaqué en deux parties, l'un en aluminium et l'autre en acier inoxydable, d'une tige en acier inoxydable.
- Concept de fixation anti-vol et anti-vandalisme.
- Ouverture d'urgence facile par le retrait du cylindre en cas de coupure de courant. Après cette opération vous pouvez faire coulisser l'Electradrop sur 120mm.
- Type de cylindre : cylindre européen 27/10, (Référence Locinox: **3012G21Z**).
- L'Electradrop doit être connecté au signal de sortie de la lumière avertisseuse (flash clignotant). Le signal du flash clignotant doit être actif au minimum trois secondes avant la séquence d'ouverture. (norme)
- Si l'Electradrop reçoit un signal de commande modulé en impulsion : Le verrou de sol descendra deux secondes après l'arrêt des impulsions. Si l'Electradrop reçoit un signal de commande continu : Le verrou de sol descendra instantanément après l'arrêt du signal.
- Course: 115mm
- Détection d'obstacle: si l'Electradrop rencontre un obstacle pendant son mouvement de descente, il s'arrêtera automatiquement à cette position. Le verrou de sol développe une force de 18Kg au cours de son mouvement.
- Relais de sortie pour détection de position haute du verrou (position de connexion 3-4; fils noirs du câble)
- Installation avec butée de sol Locinox, type OGS.

Course: 115 mm

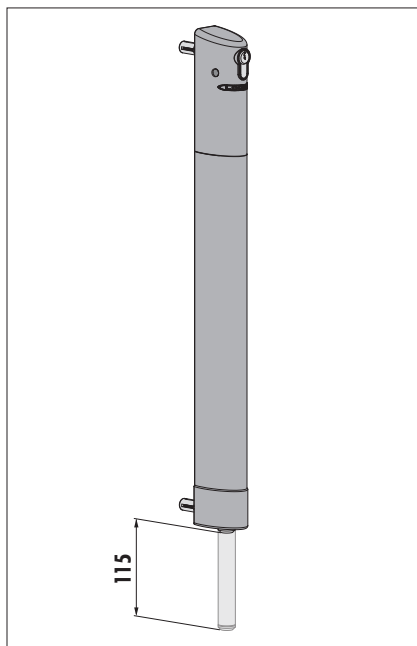

Ouverture d'urgence: 120 mm

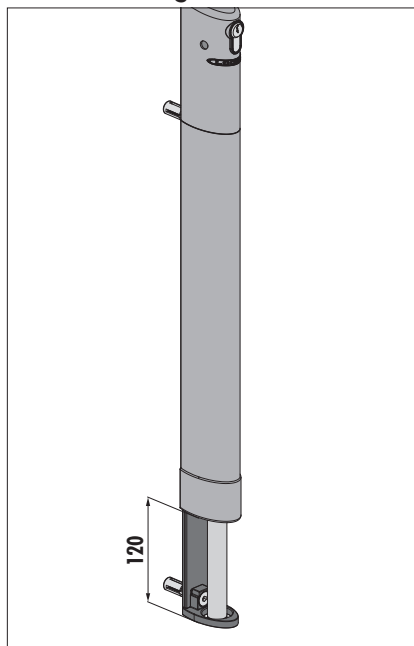

4. Spécifications électriques

À connecter sur alimentation Locinox DC-POWER-24V/25W

Tension	24V DC (polarité sécurisé)
Puissance	11 W
Puissance au repos	0,2 W
Classe d'isolation	□
Tension maximale de commutation du contact (3-4)	200V (DC or peak AC)
Courant maximal de commutation du contact (3-4)	1A (DC or peak AC)
Puissance maximale de commutation du contact (3-4)	20W

5. Circuits de temps

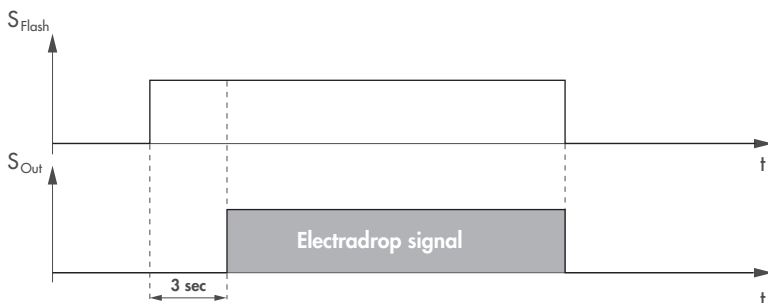
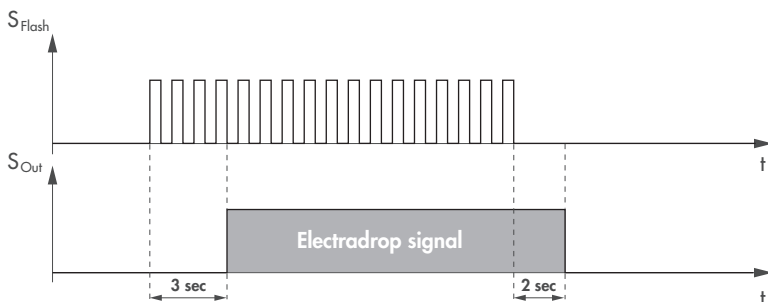

6. Montage

Etape 1: Préparation de la porte

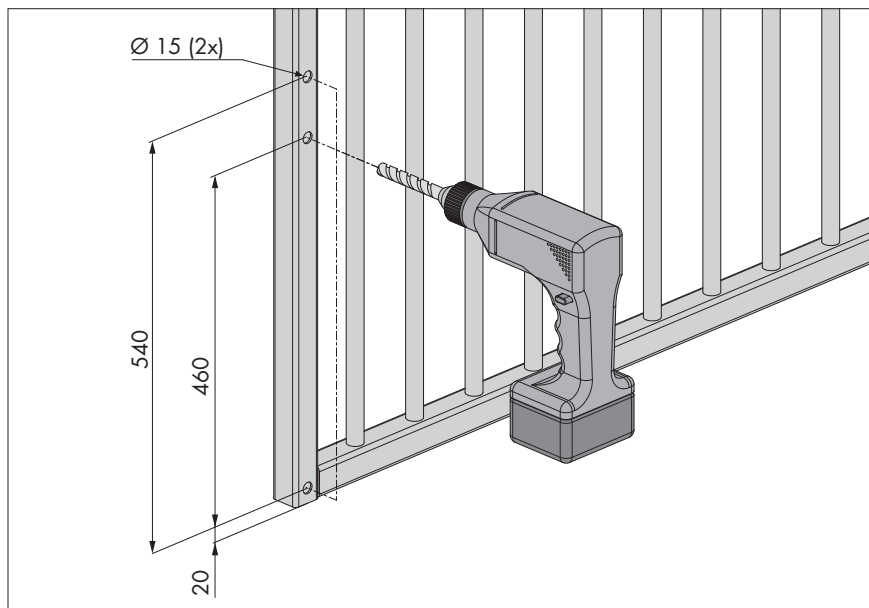

Etape 2: Déverrouiller l'Electradrop et retirer le cylindre

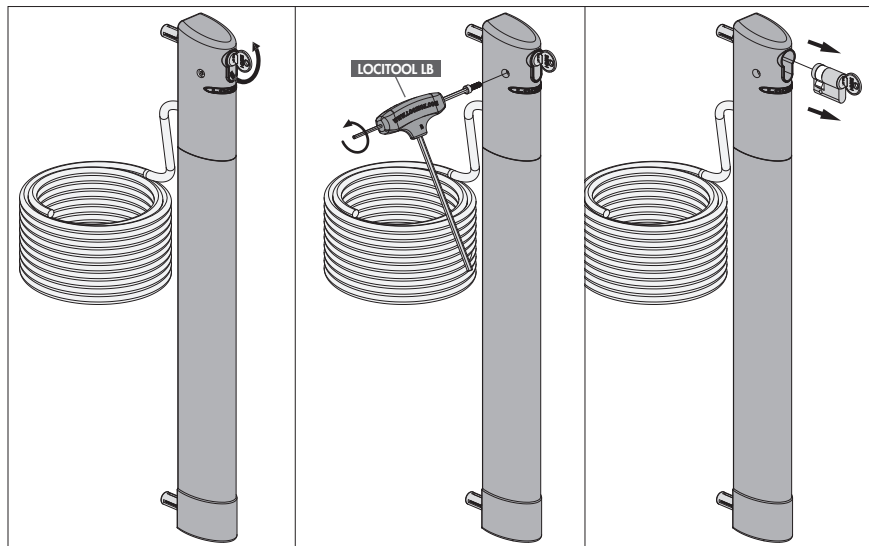

Etape 3: Passer le câble à l'intérieur du profil de la porte



Etape 4: Montage de l'Electradrop

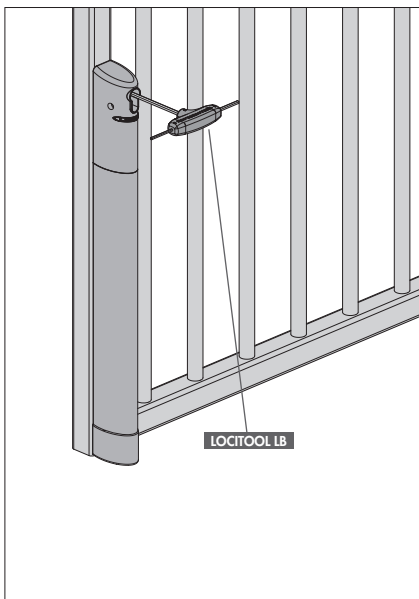
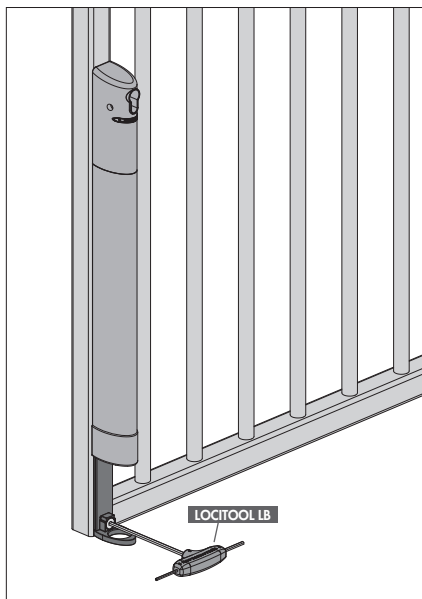

Etape 5: Montage du cylindre

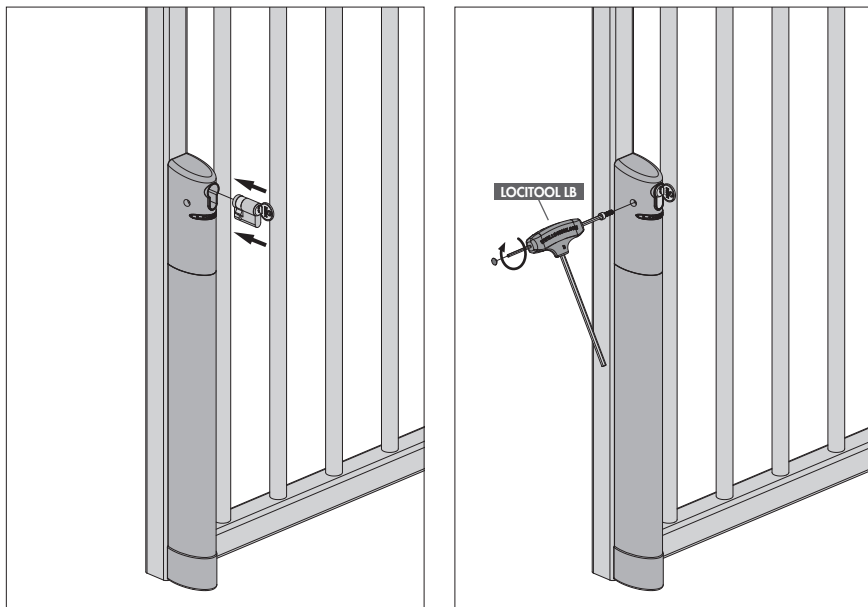

Etape 6: Utiliser l'Electradrop en combinaison avec la butée de sol Locinox OGS

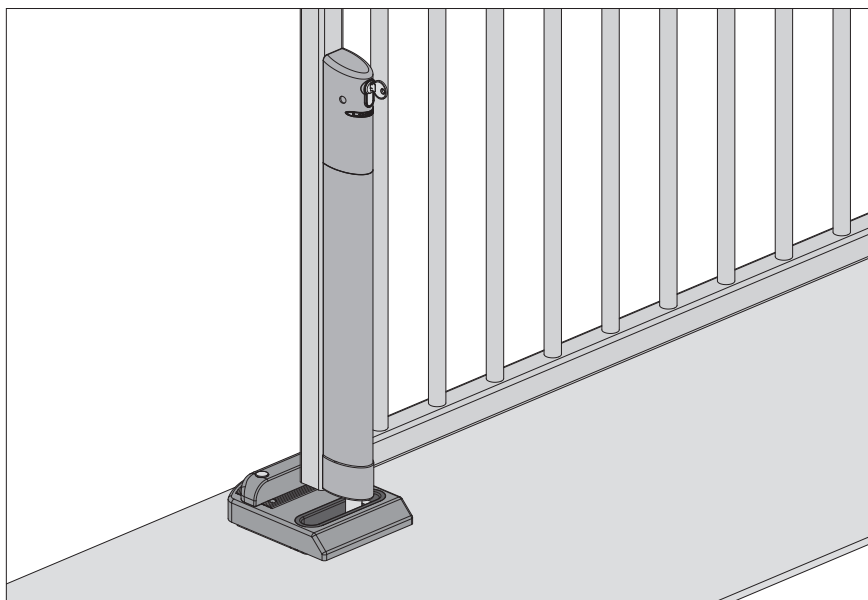

7. Câblage électrique

⚠ Choix du relais: Le type de relais dont vous avez besoin dépend du type de la lampe clignotante utilisé par le système. Par exemple: Quand vous utilisez du 230V pour la lampe, vous avez besoin d'utiliser un relais avec un voltage de 230V.

1	Marron	Pôle plus(+) de l'alimentation 24V DC (+)
2	Gris	Lampe avertisseuse venant du relais
3	Noir	Optionnel: Pour connaître la position du verrou de sol
4	Noir (ou Blanc)	
5	Bleue	Pôle moins (-) de l'alimentation 0V DC (-)
Signal de contrôle		Connexion parallèle sur la lumière avertisseuse de la porte

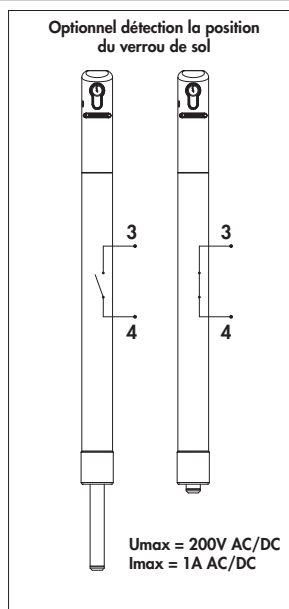
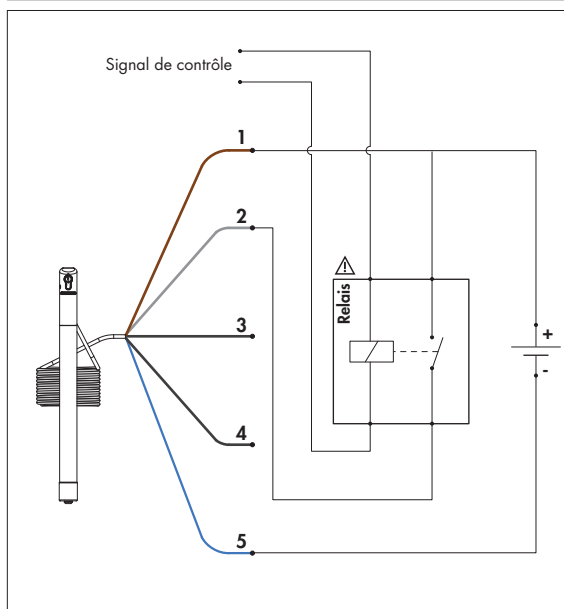

8. FAQ

- Que se passe-t-il si il y a un obstacle dans la butée de sol tel que des cailloux ou autres ?
Grâce au système de détection d'obstacle, la tige de l'electradrop s'arrêtera de descendre à chaque fois qu'il rencontrera un obstacle.
- Que se passe-t-il si le câble d'alimentation de l'Electradrop est coupé ?
L'electradrop restera dans sa dernière position.
- En cas de panne de courant, comment puis-je retirer l'Electradrop ?
L'electradrop peut être facilement retiré de la porte en enlevant le cylindre. Une fois cette opération réalisée, il suffit de faire coulisser l'Electradrop sur le rail de fixation.

Anleitung - Deutsch

1. Einleitung

Danke, dass Sie sich für einen Locinox elektrischen Torfeststeller entschieden haben. Lesen Sie gründlich nachfolgende Instruktionen, bevor Sie den Electradrop montieren. Anbei erhalten Sie alle wichtige Information bezüglich des Electradrops.

2. Paketinhalt & Abmessungen

Prüfen Sie nach, ob Ihr Paket folgendes enthält:

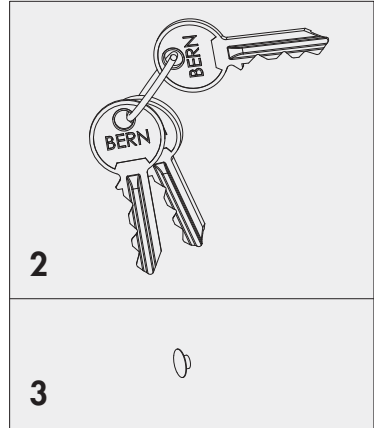
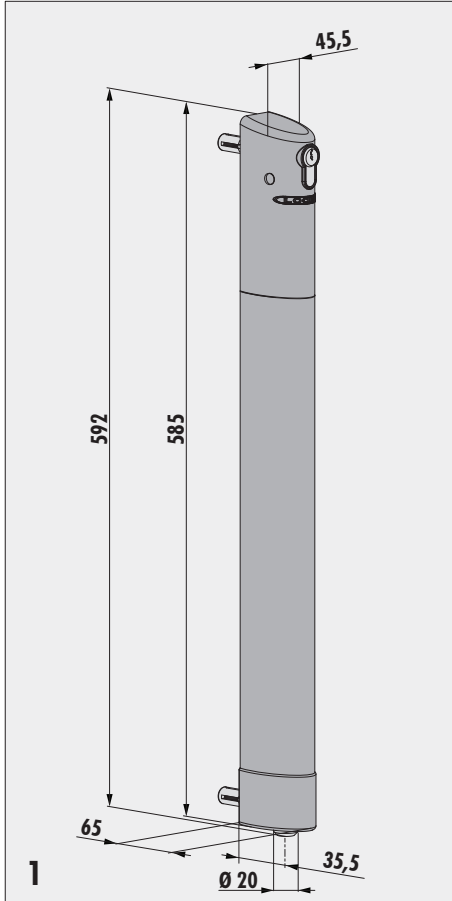

1	Elektrischen Torfeststeller (1x) & Anschlusskabel 5 m mit $5 \times 0,5 \text{ mm}^2$
2	Schlüssel (3x)
3	Polyamid Abdeckkappe (1x) zum Schutz der Befestigungsschraube des Zylinders

Kontaktieren Sie Ihren Lieferant, falls eins dieser Teile fehlt oder beschädigt ist.

3. Besonderheiten des Electradrops

- Der Electradrop ist ein automatischer Torfeststeller, speziell entwickelt für die Anwendung bei Toren mit Antrieb im Außenbereich.
- Dieser Artikel verfügt über ein pulverbeschichtetes Aluminium-/Edelstahlgehäuse und eine Edelstahl Achse.
- Antidiebstahl- und Vandalismusbeständiges Befestigungskonzept.
- Einfache und schnelle Notentriegelung bei Strompanne; Durch Entriegelung des Zylinders kann man den Electradrop 120mm hoch schieben.
- Zylinder-Typ: Europrofil-Halbzylinder 27/10, (Locinox Zylindercode: **3012G21Z**).
- Der Electradrop soll mit der Blinkwarnleuchte der Steuerungseinheit der Automatisierung verbunden werden. Eine Zeitspanne von 3 Sekunden wird benötigt, um den Riegel hochzuziehen bevor die Motoren aktiviert werden. Wenn der Electradrop ein pulsierendes Signal empfängt, wird der Riegel automatisch wieder runtergefahren, 2 Sekunden nachdem der Impuls aufhört. Wenn der Electradrop ein kontinuierliches Signal empfängt, wird der Riegel automatisch runtergefahren sobald der Impuls aufhört.
- Tiefenverriegelung: 115mm
- Hindernis Detektion: Sobald der Electradrop bei der Bewegung nach unten auf ein Hindernis trifft, wird er automatisch an dieser Position stoppen. Während der Bewegung nach unten entwickelt der Mittelfeststeller eine Kraft von 18 kg.
- Ausgang mit Detektion beim Erreichen der oberen Achsenposition (Anschluss Position 3-4; 2 schwarze Kabel-Ader)
- Montage mit Locinox-Bodenanschlügen, Typ OGS

Tiefenverriegelung: 115 mm

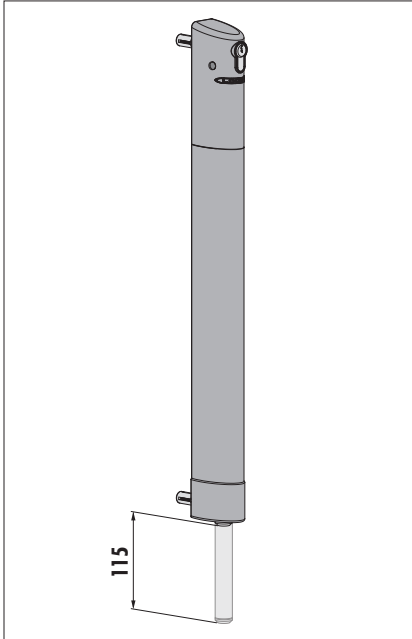

Notentriegelung: 120 mm

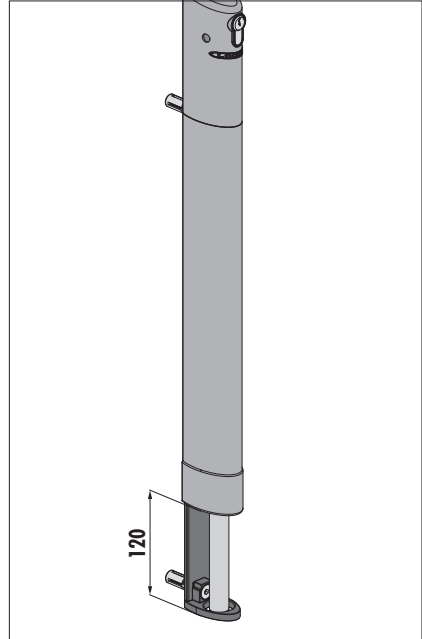

4. Elektrische Daten

Anschliessbar an Locinox DC-POWER-24V/25W Stromversorgung

Spannung	24V DC (Polarität gesichert)
Leistungsaufnahme	11 W
Leistungsaufnahme bei Ruhe	0,2 W
Isolierungsklasse	□
Maximaler Wert der Schlatspannung am Kontakt (3-4)	200V (DC oder Spitzenwert AC)
Maximale Stromstärke am Kontakt (3-4)	1A (DC oder Spitzenwert AC)
Maximale Leistungsstärke am Kontakt (3-4)	20W (Jede DC-Kombination von V und A darf die einzelnen Grenzwerte nicht überschreiten)

5. Zeitschaltung

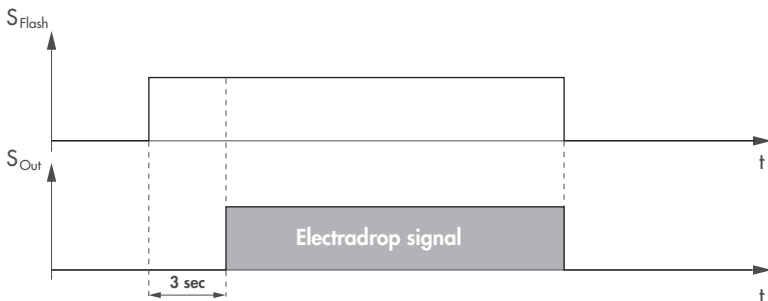
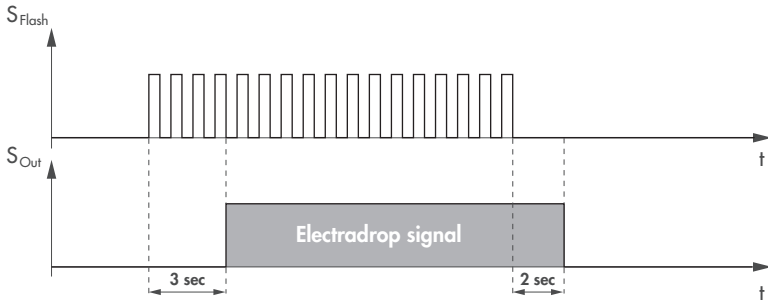

6. Montage

Schritt 1: Vorbereitung des Tores

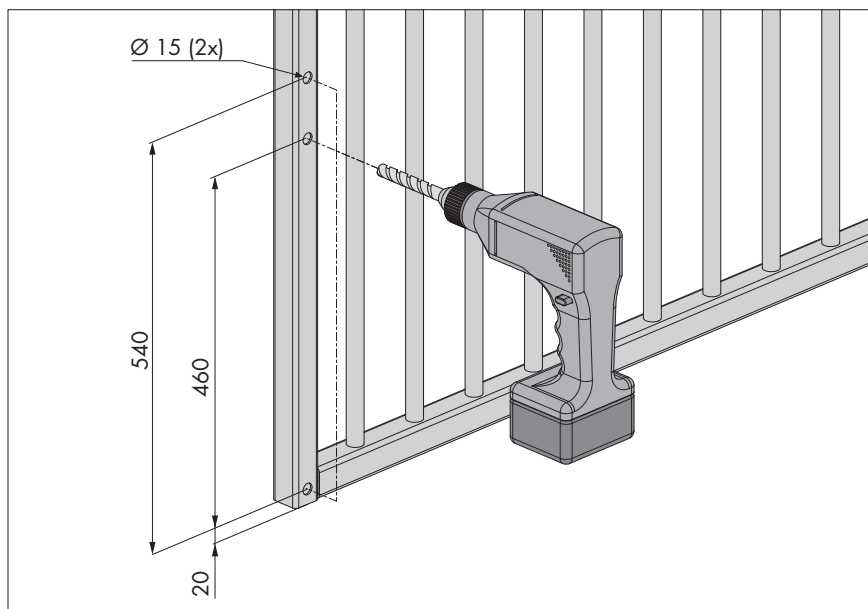

Schritt 2: Entriegeln Sie den Electradrop und entfernen Sie den Zylinder

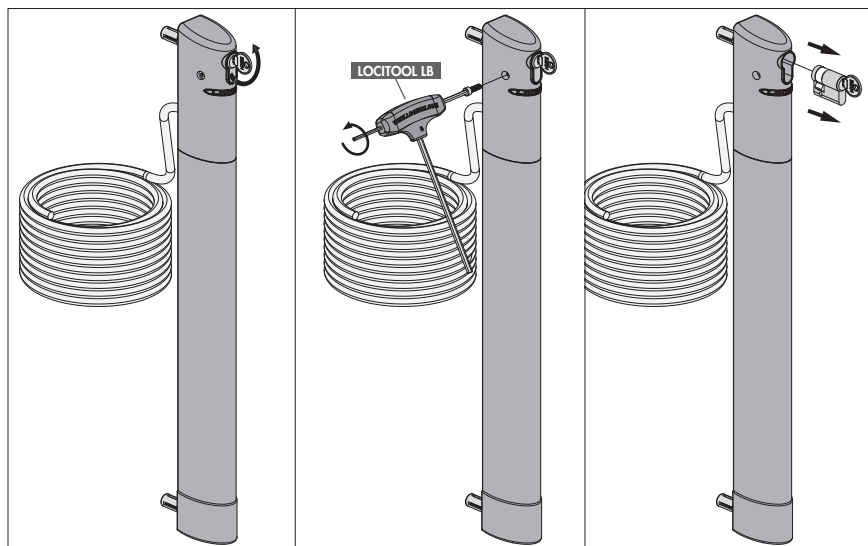

Schritt 3: Verlegen Sie das Kabel im Torrahmen



Schritt 4: Montieren Sie den Electradrop

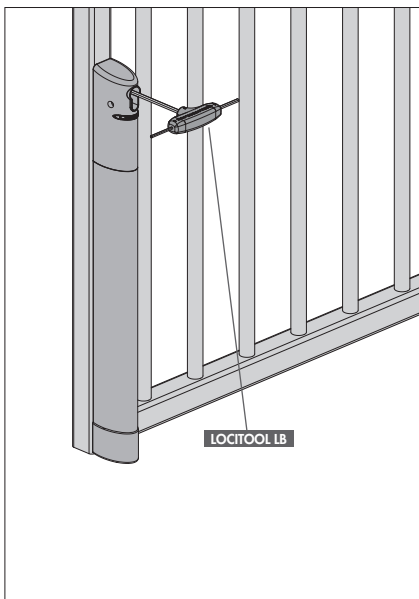
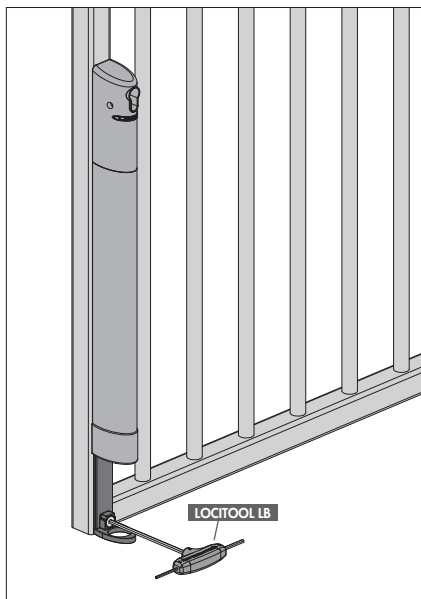

Schritt 5: Montieren Sie den Zylinder

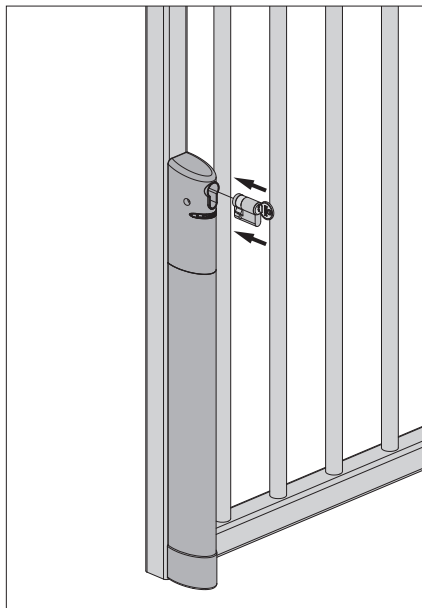

Schritt 6: Verwenden Sie den Electradrop in Kombination mit dem Locinox OGS Bodenanschlag

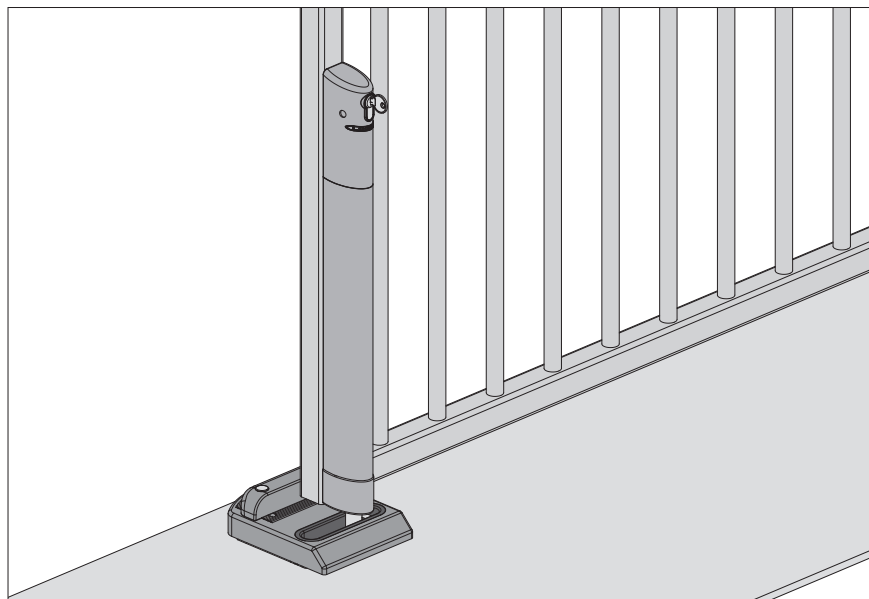

7. Elektrische Verbindung

⚠ Auswahl des Relais: Der zu verwenden Relais-Typ ist abhängig von der Blinkwarnleuchte der Automatisierung. Bei z.B. eine 230V Blinkwarnleuchte soll man einen Relais mit Spulenspannung 230V verwenden.

1	Braun	Plus-Pol der Stromversorgung 24V DC (+)
2	Grau	Relais-Signal der Blinkwarnleuchte
3	Schwarz	Fakultativ: Auslesen der Verriegelungsposition
4	Schwarz (oder weiss)	
5	Blau	Nul-Pol der Stromversorgung 0 V DC (-)
Ansteuer-Signal		Paralleler Anschluss über der Blinkwarnleuchte

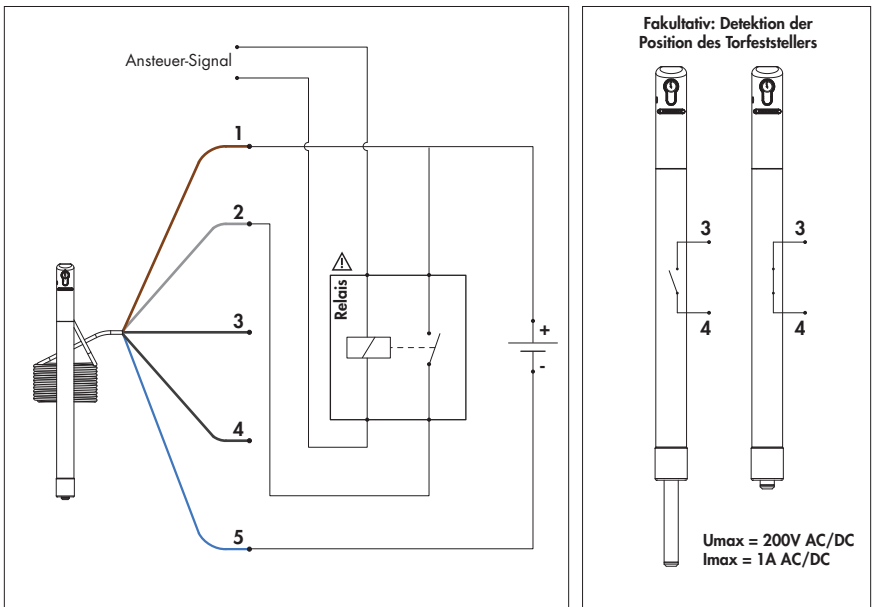

8. FAQ

- Was passiert, wenn der Bodenanschlag verschmutzt ist (z.B. mit Sand)?
Dank der integrierten Hindernisdetektion wird die ausfahrende Achse des Electradrop stoppen, sobald er auf ein Hindernis trifft.
- Was passiert, wenn das Stromkabel des Electradrop durchgeschnitten wird?
Der Electradrop bleibt in der Position stehen, in der er sich befindet.
- Wie entferne ich der Electradrop im Falle einer Stromunterbrechung bzw. eines Netzasusfalls?
Durch Entriegelung des Zylinders kann man den Electradrop 120mm hoch schieben.

Lined writing area consisting of multiple horizontal lines for text entry.

Blank lined page for writing or notes.



* M A N U - 0 0 0 1 0 0 *

2014-12-16 - rev 2

Copyright © 2012 Locinox. All rights reserved.
All specifications and figures are subject to change without notice.

Locinox nv - Mannebeekstraat 21 - B-8790 - Waregem - Belgium
Tel. +32 (0)56 77 27 66 - Fax. +32 (0)56 77 69 26
E-mail: locinox@locinox.com - Web: www.locinox.com