



# iVISION+

Wireless Video Intercom

## IVP-HU(G) (Handheld Monitor Unit) Installation Instructions



### ATTENTION:

Thank you for purchasing the iVISION+ wireless video intercom. Before installation and usage, please read this instruction manual thoroughly and keep this safe for future reference.

### IVP-HU(G) features

- 2.4 inch TFT LCD Monitor
- Wall-mountable Cradle
- Max 4 Units in a System
- micro-USB port to PC connection
- Manual/Auto Talk Switching

## 1. IMPORTANT NOTICE

**Operations under harsh environments** such as out of warranted temperature, rapid temperature change, high humidity, constant moisturization may cause the unit to malfunction.

**Electronic device** such as TVs, Radios, PCs, Microwave ovens or any other device with an electric motor may cause the unit to malfunction.

**Impact or shocks** can cause severe damage to the unit. Please handle the unit with care and operate without exerting strong forces.

**Transmission range** of communication between units may decrease under the following conditions.

- Any unit is installed on a metal surface.
- Presence of reinforced concrete, steel doors or other metal construction materials between units.
- Places near strong radio sources such as broadcast stations or substations.

**Avoid using** the Handheld Monitor Unit in the following areas

- Close to a fire, thermal appliance or other source of extreme heat/cold.
- Within 10ft (3m) of a television, microwave oven, personal computer, wireless LAN equipment, wireless audio/visual equipment - the radio frequency waves emitted by these devices can affect operation.
- In direct sunlight.
- Where extreme fluctuations in temperature can occur - if moving the unit from a warm to cold environment, or vice versa, please allow 30 minutes before use.

### Privacy & portrait/image rights

- Please respect the privacy and image rights of others when using this equipment. By using this equipment the user assumes total responsibility in upholding these rights.
- Images stored must not be used for any purpose other than that for which the equipment is designed.
- Images should be deleted once no longer required.

## 2. PARTS IDENTIFICATION

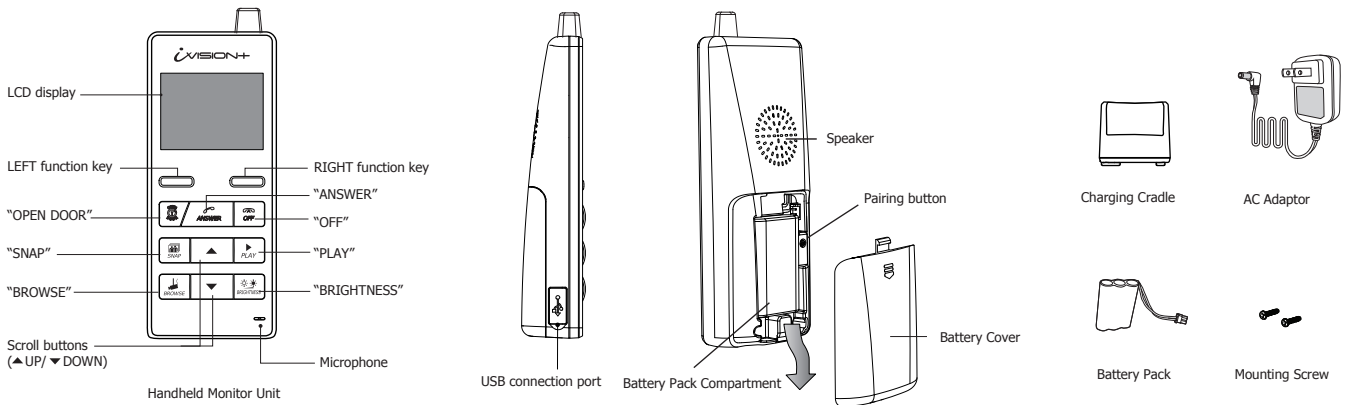

## 3. CHOOSING LOCATION

The performance of the iVISION+ system is dependent on the radio frequency environment and distances between devices. Following materials may decrease the maximum transmission distance and may cause the Handheld Monitor Unit inability to respond to incoming signals.

- Metal barricades such as metal doors and shutters.
- Walls with aluminium foil insulation.
- Concrete or galvanized metal walls.

The effective communication range is around 300ft (100m) in an open air condition (line of sight). This range will be significantly reduced by the number and thickness of walls through which the signal is required to pass. Please keep to a minimum number of walls wherever possible.

Handheld Monitor Units use 2.4GHz radio frequency. Any electrical appliance may become a potential cause for malfunction. Please avoid using the Handheld Monitor Unit near microwave oven or any electrical devices with similar radio frequency.

## 4. INSTALLATION

Handheld Monitor Unit must be set on Charging Cradle to retain its power while iVISION+ system is not in operation. The Charging Cradle can either be free-standing on a horizontal surface or be mounted on a wall as described below.

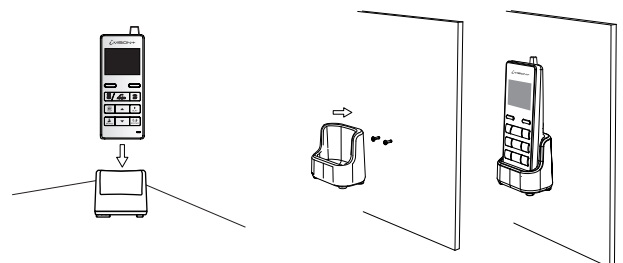

## 5. POWERING THE UNIT

### CAUTION

Please use the included battery pack and a power adaptor only. Do not disassemble or attempt to use alternative battery packs.

Remove and keep the battery separately if the device is not used for more than a month. It may require several charge-discharge process before a battery regains its full capacity after a long storage period.

1. Connect Battery pack to the main unit.

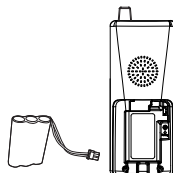

2. Connect AC adaptor to Charging Cradle

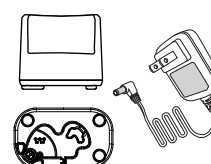

3. Press and hold "OFF" button to power on. Set the unit onto the cradle for charging.



## 6. PAIRING WITH OTHER iVISION+ DEVICES

NOTE: One Handheld Monitor Unit (IVP-HU) must be configured to have a HOME ID\*1 prior to pairing up with other iVISION+ devices. Handheld Monitor Unit bundled with Door Camera Unit already has a HOME ID set up and paired up to each other.

\*1 HOME ID is a unique network identification protocol for iVISION+ system. One Handheld Monitor Unit can issue the HOME ID and all other devices on the same system must be assigned the same HOME ID.

### 6-1 How to create HOME ID by a Handheld Monitor Unit

#### WARNING

Any pre-existing HOME ID set up will be cleared out with this procedure.

- (1) Press "OFF" and then press pairing button in the back of the unit once. The IVP-HU will be in a pairing mode.
- (2) Press the pairing button again and hold until the unit makes a beep sound.
- (3) Press "Left function key" on the front to confirm "CREATE."

### 6-2 How to enroll other iVISION+ devices to the Handheld Monitor Unit

- (1) Press pairing button in the back of IVP-HU. The unit will be in "PAIRING MODE".
- (2) Proceed to "SCAN" by pressing "Left function key". IVP-HU starts scanning for other devices for 60 seconds.
- (3) Prepare other iVISION+ device into their pairing mode. (REF: 6-3)  
When the device is ready, the new unit will be enrolled to the HOME ID and IVP-HU shows which device was connected.
- (4) If another device needs to be enrolled, re-enter "SCAN" by "Left Function key" and repeat the process.

## 7. OPERATION CHECK

### 7-1 Confirming number of iVISION+ devices in a HOME ID

- (1) In a normal operation mode, press and hold the left function key for two seconds to enter menu mode.
- (2) Select menu number 3 # DEVICES IN NETWORK by up and down key.
- (3) Press LEFT function key to "OK"
- (4) The display will show the number of iVISION+ devices in the network. Confirm number of iVISION+ devices registered with the HOME ID.
- (5) Maximum numbers of devices in an iVISION+ system are;  
2 IVP-DU, 2 IVP-GU and 4 IVP-HU. Go over pairing procedure unless optimal numbers of devices are displayed.



### 6-3 REFERENCE: How to enter "pairing mode" in iVISION+ devices

#### IVP-DU: Door Camera Unit

If not purchased in a bundle package, IVP-DU is in the pairing mode when powered up. IVP-DU beeps continuously when PUSH button is pressed. To purposely enter into a pairing mode, press PUSH button once and hold a pairing button in a back.

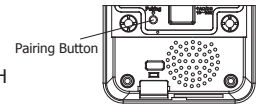

#### IVP-HU: Handheld Monitor Unit

If not purchased in a bundle package, IVP-HU is in the pairing mode when powered up. Choose "JOIN" by "Right function key" to enroll into an existing HOME ID. If otherwise, follow the instruction 6-1 to create a new HOME ID. After an enrollment of new HU, reset a Time & Date on HU1 to reflect the setting onto the added HU unit.

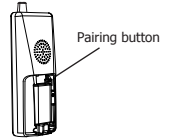

#### IVP-GU: Gateway Chime Unit

If not purchased in a bundle package, by the factory default, IVP-GU is in the pairing mode when powered up. IVP-GU beeps continuously and green/red LED blinks. Press down both A and B buttons while powering up the Gateway Chime Unit to enter the pairing mode.

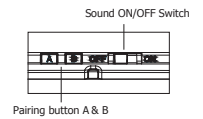

## 7. OPERATION CHECK

### 7-2 Checking operations on Handheld Monitor Unit

- (1) Make sure IVP-HU has been charged and there is a green indication on the top of display.
- (2) To confirm RF reception, bring IVP-HU and IVP-DU in a line of sight.
- (3) Press "Push button" on a paired Door Camera Unit.  
All paired IVP-HUs display an image from the IVP-DU.
- (4) Press "Answer" on any of the IVP-HU.  
Voice from IVP-HU will be heard from the IVP-DU.
- (5) Press "OFF" on the IVP-HU to terminate the communication.
- (6) Move IVP-HU (and IVP-DU) to a desired location and repeat (3) to (5) to confirm reception of signals.

## 8. SPECIFICATION

### 8-1 Dimensions

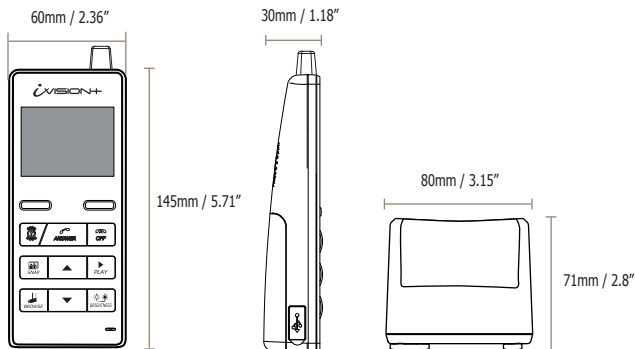

### 8-2 Specification Table

MODEL NAME: OPTEX iVISION+ (IVP-HU) Handheld Monitor Unit

Operating Temperature	0 to 40 degC (32 to 104 degF)
Operating Humidity	< 90% RH (no condensation)
Dust/Water Protection	N/A (Indoor Use Only)
Radiowave Frequency	2.4 GHz
Power	Power Adaptor 5.5V DC

Use designated battery, IVP-BAT, for IVP-HU.

Please contact your regional technical support for procurement information.

## 9. WARRANTY

1. This product is under a warranty for a normal usage for 18 months from the date of manufacturing. The date of manufacturing can be identified from a LOT number indicated on a label placed in battery compartment of IVP-HU.

LOT: YYYWZ (e.g. LOT 1350Z)

YY indicates last two digits of the year manufactured (e.g. "13" = Year 2013)

WW indicates Xth week of the year manufactured (e.g. "50" = 50th week)

2. The warranty may **not be applicable** when any of following circumstances is found.
  - Mechanical or electrical modification is made to the product and the good's appearance indicates an alterations or a significant damage.
  - The product is already been diagnosed by someone other than the manufacturer.
  - Product malfunction is resulting from an improper usage, an accident, natural disaster or any environmental event.
  - Please call our technical assistance before arranging a return.



OPTEX CO., LTD. (JAPAN)

URL: <http://www.optex.net/>

#### OPTEX INC. (U.S.)

URL: <http://www.optexamerica.com/>

#### OPTEX DO BRASIL LTDA. (Brazil)

URL: <http://www.optex.net/br/es/sec/>

#### OPTEX (EUROPE) LTD. / EMEA HQ (U.K.)

URL: <http://www.optexeurope.com/>