

Indoor/Outdoor Pendant Wall Mount

CM-MT-WALL1

Pendant wall mount for dome cameras. Compatible with H4 SL, H4 Fisheye, H4 PTZ and H3 Multisensor dome cameras.

Weight: 1.27 kg (2.80 lbs)

Finish: Powder coat, RAL 9003

Body: Aluminum, stainless steel, silicone rubber

- Female 1-1/2" NPS camera mount
- 3/4" NPT conduit entry
- Creates outdoor seal with pendant dome cameras that meets IP66 standards

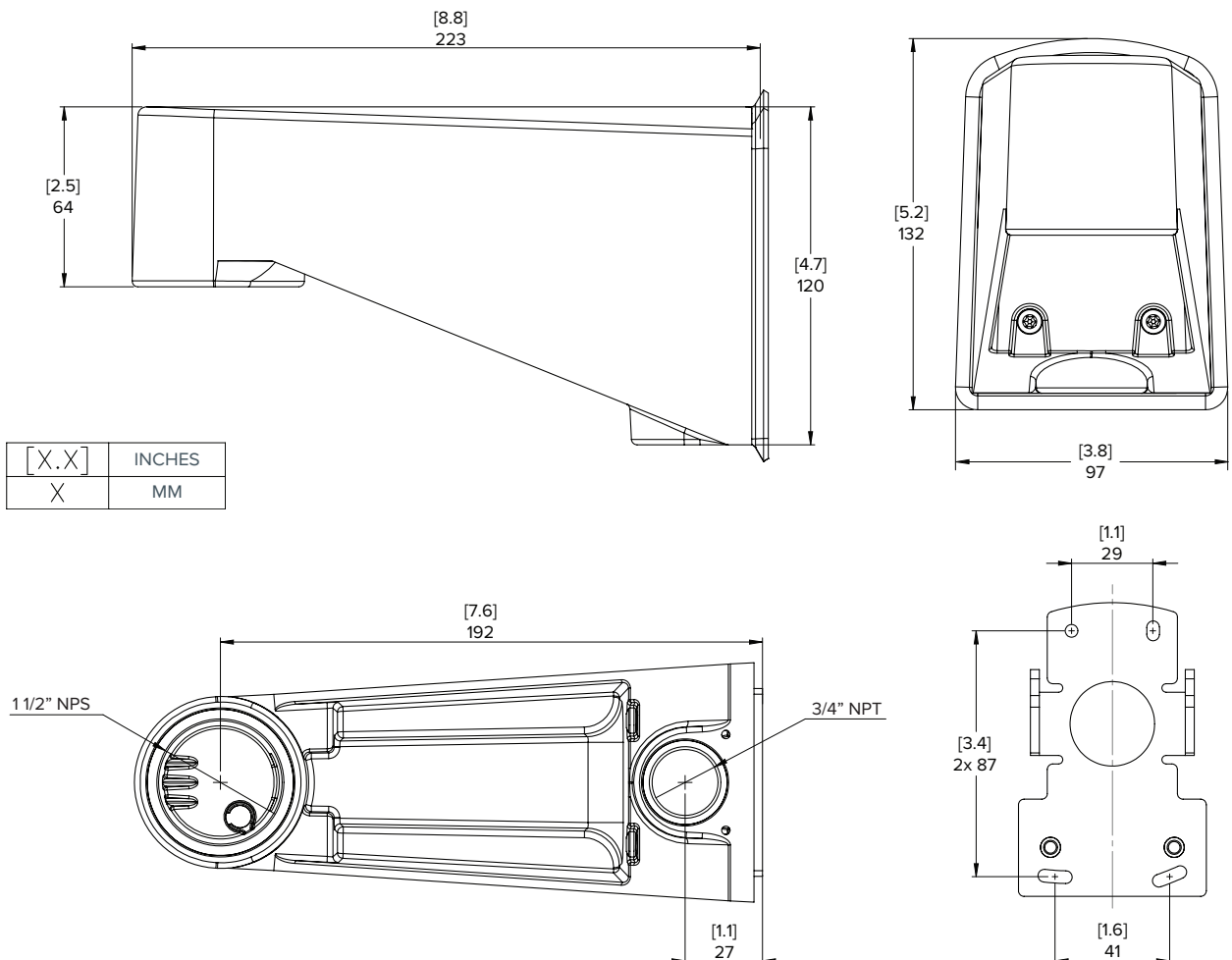

SUPPORT 1.888.281.5182 | sales@avigilon.com | avigilon.com