



ACT5 DIGITAL KEYPAD

30 SECOND PROGRAMMING GUIDE

1. Enter Programming Mode. (for typical system) Press X button followed by the programming code (9999) The LED will flash Amber
2. Change User 1 code. Press 0, then 1 followed by the new user 1 code (four digits)
3. Change Programming Code. Press 0, then 1 followed by the new programming code (four digits).
4. Set Desired Relay Active Time. Press 2, then 0. Allow the buzzer to sound for the desired period. Press 1 to stop – this period is now programmed into the relay timer.
5. Exit Programming Mode. Press the X button. The LED will be Red.

The keypad is now ready for normal use.

Note: The keypad may be returned to its factory default condition at any time by entering the programming mode and pressing the X three times.

ACT5 Digital Keypad Programming

INSTALLATION NOTES

- Always remember to factory default the controller before you start programming.
- Always remember to place the supplied Varistor across the terminals of the door strike coil to protect the relay contacts.
- Never use the onboard relay to switch AC mains voltage. An external relay isolated electrically from the ACT5 should be used for this purpose.
- Don't forget to change the programming code to something known only to yourself.

IMPORTANT

As with any access control system, always ensure that there is an alternate means of escape in the event of the unit failing to operate due to power loss or in the event of fire.



Unit 8, IDA Business Park,
Whitestown, Dublin Ireland.

Tel: 353-1-4622585 Fax: 353-1-4622587,

Copyright © 2003 Access Control Technology Ltd.

(18-00001-27)

For full details on the ACT product range and a list of distributors, Visit our website www.accesscontrol.ie

Changing Codes:

(From programming mode) Enter 0 (Change codes) 0-9, 1 (user number 0-9, 1 = programming code) 0000-9999 (4 digit code – 0000 deletes user) Default user codes : Programming = 9999, User 1 = 1234, All others inactive.

Setting the Relay active time:

(From programming mode) Enter 2 (Set Relay active Time) 0 (Relay Timer) {Buzzer sounds indicating timing... wait required period} (Stop timing) {Buzzer stops — timer set}

Incorrect Code Lockout

When three invalid codes have been entered in a row. The keypad will enter lockout mode for 20 seconds. During this time, the red indicator will flash and all user coded will be inactive.

Restoring Factory Defaults

(From Programming Mode) 1 (Factory Defaults Restored & Keypad exits programming mode)

1. Remove the power from the unit.
2. Remove link LK1.
3. Apply power to unit.
4. Replace link LK1.
5. Remove power again.
6. Restore power and proceed with programming.

Note: The keypad will not operate correctly without LK1 in place.

Fig 1 ACT5 Wiring Diagram

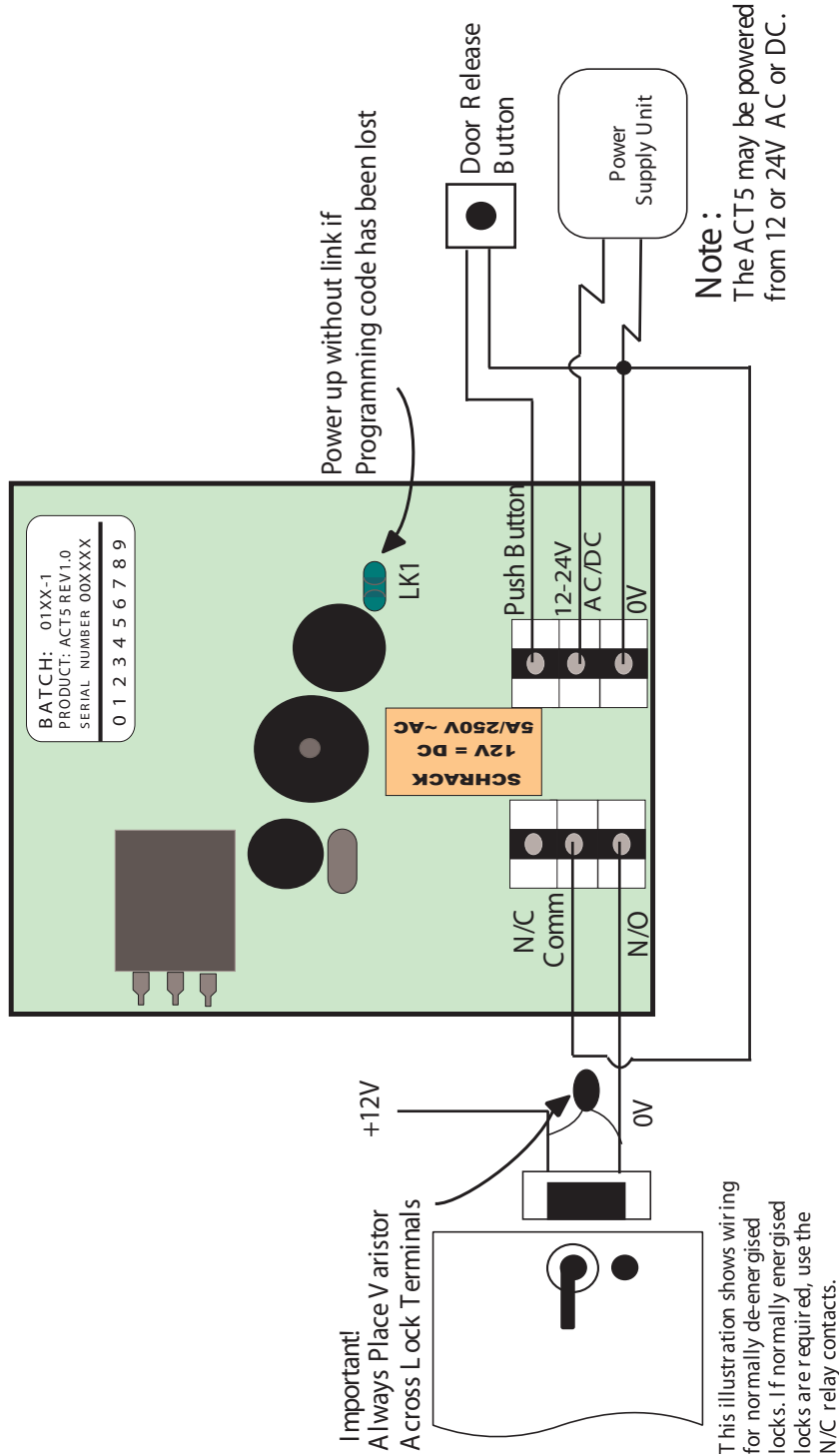

Fig 2 Mounting instructions for flush mount unit

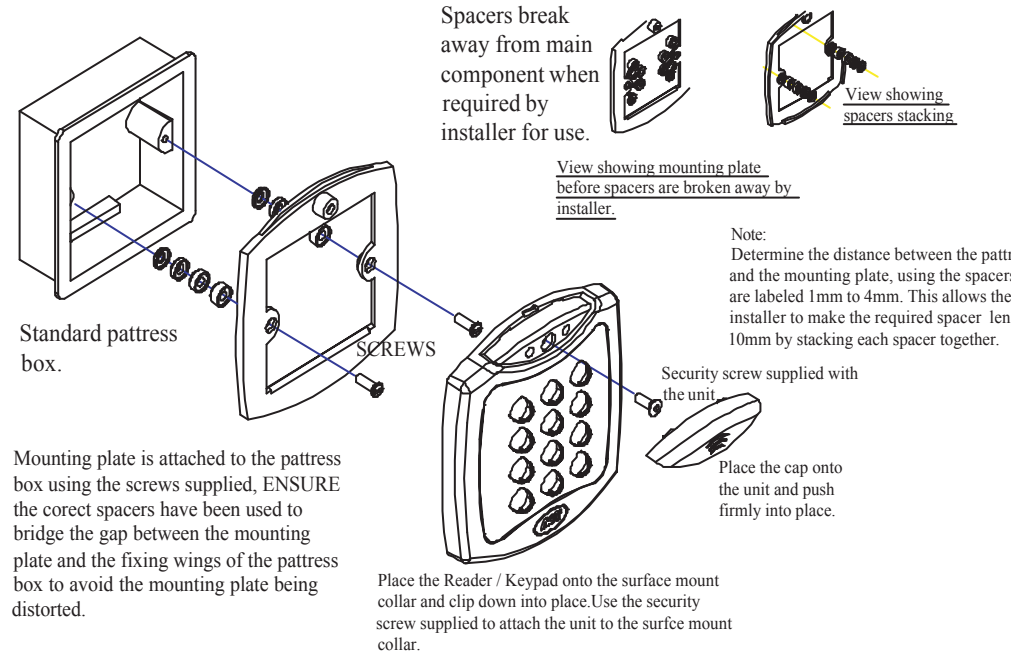

Fig 3 Mounting instructions for surface mount unit

