

2 WIRE BUS VIDEOKIT CESVK/KRISTALLO/S SERIES



The CESVK video kits require only 2 wires to carry video, audio and data. Developed from the VX2300 2 Wire digital video door entry system, the video kit uses the same devices (intercoms, videophones, videomonitors, distributors, exchangers, power supplies etc.) and offers the following facilities:

- Facility to make multiple entrance systems using the exchanger Art.2301N;
- Facility to make systems with up to 7 users (requires Art.4333 firmware revision 2.0 or later and the purchase of additional items);
- Facility to connect up to 4 intercoms/videophones in parallel using the distributor Art.318 (if videophones must be switched on at the same time, the additional videophones must be powered separately);
- Intercommunication between intercoms/videophones inside the same apartment or between intercoms/videophones inside different apartments (two way videokit);
- The use of the Art.2305 BUS relay for additional services;
- Disability Friendly - Acoustic & Visual signalling of the system status (busy, call in progress, conversation in progress and door open signalling);
- Recall (selective entrance recall on systems with 2 or more outdoor stations);
- Local call tone which is different from the external push button call tone;
- Videophone incorporates "Privacy" On/Off facility (with either latched or timed activation of privacy);
- Programmable Call, conversation and door opening times;
- Dry relay contacts for electric lock.

CESVK-1/KRISTALLO/S

One button videokit comprising of:

1 Outdoor station including speaker unit module Art.4333-1/Colour comprising of high quality auto iris lens CCD Day/Night colour camera* with infrared illumination LEDs plus one module flush mounting box with module support and hinge Art.4851.

Standard finish: mirror stainless steel for the front plate and gun metal grey for the module support.

1 Art.KRV86 Intelligent Hands free video monitor for the VX2300 digital system using 3.5" OSD full colour active matrix LCD monitor, with touch sensitive buttons for "door open/service", "answer/camera recall", "privacy/bus relay" plus 5 navigation menu buttons and 3 LEDs** related to the videophone operation. Surface mounting version.

In addition to the hands free mode the handset is also available in order to use as a traditional intercom.

1 Art.2321 Specific power supply in a Type A 9 module DIN box.

Packing: cardboard 43x27x10 cm total weight 3.8 Kg.

CESVK-2/KRISTALLO/S

As CESVK-1 but two call button version speaker unit Art.4333-1D/Colour and 2 videophones Art.KRV86.

Packing: cardboard 26x29x25cm total weight 4.1 Kg.

CESVK-1S/KRISTALLO/S, CESVK-2S/KRISTALLO/S

As the versions with the flush mount outdoor station but with surface mounting box Art.4881.

Packing: the same as equivalent flush model with total weight of 4.1 Kg for one button version and 4.9 Kg for two button version.

The module support frame, module front plate and videophone are available in other finishes, see pictures 4, 5 and 7 on page 33 for available versions and additional suffix to use for orders.

The above colour kits can be ordered with an alternative model videophone, see page 34 to check their features, code, photos and dimensions.

* Available also with Wide Angle camera option.

** Some LED's require additional connections in order to work.

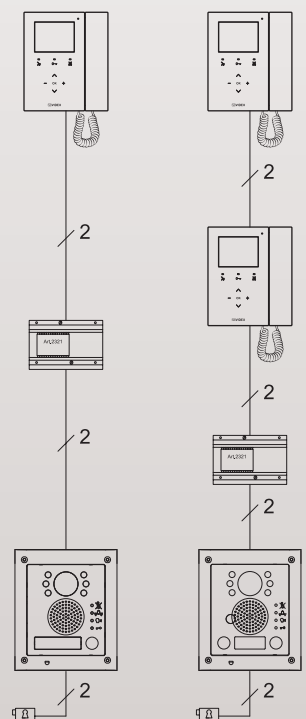

CESVK-1S/KRISTALLO/S/W